

INDUSTRY PROCESS  
AND AUTOMATION SOLUTIONS



**BONFIGLIOLI**  
**RIDUTTORI**

C



**BONFIGLIOLI**



**INFORMAZIONI GENERALI**  
**GENERAL INFORMATION**  
**ALLGEMEINE INFORMATIONEN**  
**INFORMATIONS GENERALES**

Paragrafo  
Chapter  
Abschnitt  
Paragraphe

Pagina  
Page  
Seite  
Page

Descrizione	Description	Beschreibung	Description	
1 Simbologia e unità di misura	<i>Symbols and units of measure</i>	Symbole und Maßeinheiten	<i>Symboles et unités de mesure</i>	2
2 Coppia	<i>Torque</i>	Abtriebsmoment	<i>Couple</i>	4
3 Potenza	<i>Power</i>	Leistung	<i>Puissance</i>	4
4 Potenza termica	<i>Thermal capacity</i>	Thermische Grenzleistung	<i>Puissance thermique</i>	5
5 Rendimento	<i>Efficiency</i>	Wirkungsgrad	<i>Rendement</i>	6
6 Rapporto di riduzione	<i>Gear ratio</i>	Getriebeübersetzung	<i>Rapport de réduction</i>	6
7 Velocità angolare	<i>Angular velocity</i>	Drehzahl	<i>Vitesse angulaire</i>	7
8 Momento d'inerzia	<i>Moment of inertia</i>	Trägheitsmoment	<i>Moment d'inertie</i>	7
9 Fattore di servizio	<i>Service factor</i>	Betriebsfaktor	<i>Facteur de service</i>	8
10 Manutenzione	<i>Maintenance</i>	Wartung	<i>Entretien</i>	9
11 Selezione	<i>Selection</i>	Antriebsauswahl	<i>Sélection</i>	10
12 Verifiche	<i>Verification</i>	Prüfungen	<i>Vérifications</i>	13
13 Installazione	<i>Installation</i>	Installation	<i>Installation</i>	15
14 Stoccaggio	<i>Storage</i>	Lagerung	<i>Stockage</i>	16
15 Condizioni di fornitura	<i>Conditions of supply</i>	Lieferbedingungen	<i>Conditions de livraison</i>	17
16 Specifiche della vernice	<i>Paint specifications</i>	Angaben zu den Anrichstoffe	<i>Spécifications de la peinture</i>	17

**RIDUTTORI COASSIALI SERIE C**  
**HELICAL GEAR UNITS SERIES C**  
**STIRNRADGETRIEBE SERIE C**  
**MOTOREDUCTEURS COAXIAUX SERIE C**

17 Caratteristiche costruttive	<i>Design characteristics</i>	Konstruktive Eigenschaften	<i>Caractéristiques de construction</i>	18
18 Forme costruttive	<i>Versions</i>	Bauformen	<i>Formes de construction</i>	19
19 Designazione	<i>Designation</i>	Bezeichnung	<i>Désignation</i>	20
20 Lubrificazione	<i>Lubrication</i>	Schmierung	<i>Lubrification</i>	24
21 Posizioni di montaggio e orientamento morsettera	<i>Mounting position and terminal box angular position</i>	Einbaulagen und lage des klemmenkastens	<i>Positions de montage et orientation boîte a borne</i>	25
22 Carichi radiali	<i>Overhung loads</i>	Radialkräfte	<i>Charges radiales</i>	38
23 Carichi assiali	<i>Thrust loads</i>	Axialkräfte	<i>Charges axiales</i>	41
24 Dati tecnici motoriduttori	<i>Gearmotor rating charts</i>	Getriebemotoreauswahltabellen	<i>Données techniques motoréducteurs</i>	42
25 Dati tecnici riduttori	<i>Gearbox rating charts</i>	Getriebe auswahltabellen	<i>Données techniques réducteurs</i>	74
26 Predisposizioni possibili	<i>Motor availability</i>	Anbaumöglichkeiten	<i>Prédispositions possibles</i>	96
27 Momento d'inerzia	<i>Moment of inertia</i>	Trägheitsmoment	<i>Moment d'inertie</i>	98
28 Dimensioni	<i>Dimensions</i>	Abmessungen	<i>Dimensions</i>	110

**MOTORI ELETTRICI**  
**ELECTRIC MOTORS**  
**ELEKTROMOTOREN**  
**MOTEURS ELECTRIQUES**

M1 Simbologia e unità di misura	<i>Symbols and units of measure</i>	Symbole und Maßeinheiten	<i>Symboles et unités de mesure</i>	144
M2 Caratteristiche generali	<i>General characteristics</i>	Allgemeine Eigenschaften	<i>Caractéristiques générales</i>	145
M3 Caratteristiche meccaniche	<i>Mechanical characteristics</i>	Mechanische Eigenschaften	<i>Caractéristiques mécaniques</i>	148
M4 Caratteristiche elettriche	<i>Electrical characteristics</i>	Elektrische Eigenschaften	<i>Caractéristiques électriques</i>	153
M5 Motori asincroni autofrenanti	<i>Asynchronous brake motors</i>	Bremsmotoren	<i>Moteurs asynchrones freins</i>	160
M6 Motori autofrenanti in c.c., tipo BN_FD	<i>DC brake motors type BN_FD</i>	Drehstrom-Bremsmotoren mit Gleichstrombremse: typ BN_FD	<i>Moteurs frein en c.c. type BN_FD</i>	161
M7 Motori autofrenanti in c.a., tipo BN_FA	<i>AC brake motors type BN_FA</i>	Wechselstrombremsmotoren: typ BN_FA	<i>Moteurs frein en c.a. type BN_FA</i>	166
M8 Motori autofrenanti in c.a., tipo BN_BA	<i>AC brake motors type BN_BA</i>	Drehstrom-Bremsmotoren mit Wechselstrombremse: typ BN_BA	<i>Moteurs frein en c.a. type BN_BA</i>	170
M9 Sistemi di sblocco freno	<i>Brake release systems</i>	Brenslüfthebel	<i>Systemes de déblocage frein</i>	174
M10 Opzioni	<i>Options</i>	Optionen	<i>Options</i>	176
M11 Dati tecnici motori	<i>Motor rating charts</i>	Motoreauswahl-tabellen	<i>Données techniques des moteurs</i>	182
M12 Dimensioni	<i>Dimensions</i>	Abmessungen	<i>Dimensions</i>	199

Revisióni  
L'indice di revisione del catalogo è riportato a pag. 212.  
Al sito [www.bonfiglioli.com](http://www.bonfiglioli.com) sono disponibili i cataloghi con le revisioni aggiornate.

Revisions  
Refer to page 212 for the catalogue revision index.  
Visit [www.bonfiglioli.com](http://www.bonfiglioli.com) to search for catalogues with up-to-date revisions.

Änderungen  
Das Revisionsverzeichnis des Katalogs wird auf Seite 212 wiedergegeben. Auf unserer Website [www.bonfiglioli.com](http://www.bonfiglioli.com) werden die Kataloge in ihrer letzten, überarbeiteten Version angeboten.

Révisions  
Le sommaire de révision du catalogue est indiqué à la page 212.  
Sur le site [www.bonfiglioli.com](http://www.bonfiglioli.com) des catalogues avec les dernières révisions sont disponibles.

**1 - SIMBOLOGIA E UNITÀ  
DI MISURA**
**1 - SYMBOLS AND UNITS  
OF MEASURE**
**1 - SYMBOLE UND  
MAßEINHEITEN**
**1 - SYMBOLES ET UNITES  
DE MESURE**

Simb. Symb.	U.m. Meße- inh.	Descrizione	Description	Beschreibung	Description
$A_{N 1, 2}$ [N]		Carico assiale nominale	<i>Permissible axial force</i>	Nenn-Axialbelastung	<i>Charge axiale nominale</i>
$f_s$	–	Fattore di servizio	<i>Service factor</i>	Betriebsfaktor	<i>Facteur de service</i>
$f_T$	–	Fattore termico	<i>Thermal factor</i>	Temperaturfaktor	<i>Facteur thermique</i>
$f_{TP}$	–	Fattore di temperatura	<i>Temperature factor</i>	Wärmefaktor	<i>Facteur de température</i>
$i$	–	Rapporto di trasmissione	<i>Gear ratio</i>	Übersetzung	<i>Rapport de réduction</i>
$I$	–	Rapporto di intermittenza	<i>Cyclic duration factor</i>	Relative Einschaltdauer	<i>Rapport d'intermittence</i>
$J_C$	[Kgm <sup>2</sup> ]	Momento di inerzia carico	<i>Mass moment of inertia to be driven</i>	Massenträgheitsmoment der externen Massen	<i>Moment d'inertie de la charge</i>
$J_M$	[Kgm <sup>2</sup> ]	Momento di inerzia motore	<i>Motor mass moment of inertia</i>	Motorträgheitsmoment	<i>Moment d'inertie du moteur</i>
$J_R$	[Kgm <sup>2</sup> ]	Momento di inerzia riduttore	<i>Mass moment of inertia for the gear unit</i>	Getriebeträgheitsmoment	<i>Moment d'inertie du réducteur</i>
$K$	–	Fattore di accelerazione delle masse	<i>Mass acceleration factor</i>	Massenbeschleunigungsfaktor	<i>Facteur d'accélération des masses</i>
$K_r$	–	Costante di trasmissione	<i>Transmission element factor</i>	Belastungsfaktor der Radiallast	<i>Constante de transmission</i>
$M$ 1, 2 [Nm]		Coppia	<i>Torque</i>	Drehmoment	<i>Couple</i>
$M_c$ 1, 2 [Nm]		Coppia di calcolo	<i>Calculated torque</i>	Berechnetes Drehmoment	<i>Couple de calcul</i>
$M_n$ 1, 2 [Nm]		Coppia nominale	<i>Rated torque</i>	Nennmoment	<i>Couple nominal</i>
$M_r$ 1, 2 [Nm]		Coppia richiesta	<i>Torque demand</i>	Benötigtes Drehmoment	<i>Couple nécessaire</i>
$n$ 1, 2 [min <sup>-1</sup> ]		Velocità	<i>Speed</i>	Abtriebsdrehzahl	<i>Vitesse</i>
$P$ 1, 2 [kW]		Potenza	<i>Power</i>	Leistung	<i>Puissance</i>
$P_N$ 1, 2 [kW]		Potenza nominale	<i>Rated power</i>	Nennleistung	<i>Puissance nominale</i>
$P_R$ 1, 2 [kW]		Potenza richiesta	<i>Power demand</i>	Benötigte Leistung	<i>Puissance nécessaire</i>
$R_C$ 1, 2 [N]		Carico radiale di calcolo	<i>Calculated radial force</i>	Berechnete Axialbelastung	<i>Charge radiale de calcul</i>
$R_N$ 1, 2 [N]		Carico radiale nominale	<i>Permissible overhung load</i>	Zulässige Radialbelastung	<i>Charge radiale nominale</i>
$S$	–	Fattore di sicurezza	<i>Safety factor</i>	Sicherheitsfaktor	<i>Facteur de sécurité</i>
$t_a$	[°C]	Temperatura ambiente	<i>Ambient temperature</i>	Umgebungstemperatur	<i>Température ambiante</i>
$t_f$	[min]	Tempo di funzionamento a carico costante	<i>Work time under constant load</i>	Betriebszeit während nennbetrieb	<i>Temps de fonctionnement à charge constante</i>
$t_r$	[min]	Tempo di riposo	<i>Rest time</i>	Stillstandszeit	<i>Temps de repos</i>
$\eta_d$	–	Rendimento dinamico	<i>Dynamic efficiency</i>	Dynamischer Wirkungsgrad	<i>Rendement dynamique</i>
$\eta_s$	–	Rendimento statico	<i>Static efficiency</i>	Statischer Wirkungsgrad	<i>Rendement statique</i>

1 valore riferito all'albero veloce

1 value applies to input shaft

1 Werte beziehen sich auf die Antriebswelle

1 valeurs pour l'arbre rapide

2 valore riferito all'albero lento

2 value applies to output shaft

2 Werte beziehen sich auf die Abtriebswelle

2 valeurs pour l'arbre lent



Questo simbolo riporta i riferimenti angolari per l'indicazione della direzione del carico radiale (l'albero è visto di fronte).



This symbol refers to the angle the overhung load applies (viewing from drive end).



Dieses Symbol gibt die Winkelbezugswerte für die Angabe der Richtung der Radialkräfte an (Stirnansicht der Welle).



Ce symbole présente les références angulaires pour l'indication de la direction de la charge radiale (l'arbre est vu de face).



Simbolo riferito al peso dei riduttori e dei motoriduttori. I valori riportati nelle tabelle dei motoriduttori sono comprensivi sia del peso del motore a 4 poli sia del peso del lubrificante contenuto, qualora previsto da BONFIGLIOLI RIDUTTORI.



Symbol refers to weight of gearmotors and speed reducers. Figure for gearmotors incorporates the weight of the 4-pole motor and for life lubricated units, where applicable, the weight of the oil.



Symbol für das Gewicht der Getriebe und der Getriebemotoren. Die in der Getriebemotoren-Tabelle genannten Werte schließen das Gewicht des vierpoligen Motors und die eingefüllte Schmierstoffmenge ein, sofern von BONFIGLIOLI RIDUTTORI vorgesehen.



Symbole se référant aux poids des réducteurs et des motoréducteurs. Les valeurs indiquées dans les tableaux des motoréducteurs comprennent tant le poids du moteur à 4 pôles que le poids du lubrifiant contenu, lorsque prévu par BONFIGLIOLI RIDUTTORI.

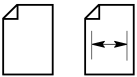

Il simbolo identifica la pagina alla quale può essere reperita l'informazione.

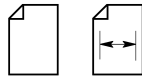

The symbol shows the page the information can be sorted from.

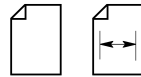

Das Symbol Kennzeichnet die Seite, auf die die Information gefunden werden kann.

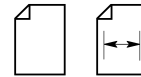

Le symbole identifie la page à laquelle l'on peut trouver l'information.

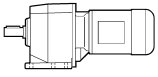

Motoriduttore con motore integrato.

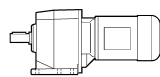

Gearmotor with compact motor.

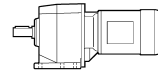

Getriebemotor mit Kompaktmotor.

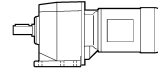

Motoréducteur avec moteur compact.



Motoriduttore abbinato con motore a standard IEC



Gearmotor with IEC motor.



Getriebemotor mit IEC-Motor.



Motoréducteur avec moteur normalisé CEI.

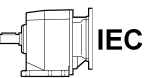

Riduttore predisposto per abbinamento con motore a standard IEC.

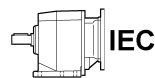

Gear unit with IEC motor interface.

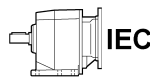

Getriebe vorbereitet für IEC-motor.

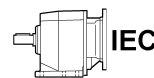

Réducteur prédisposé pour liaison a moteur IEC.

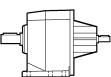

Riduttore dotato di albero veloce cilindrico.

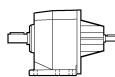

Speed reducer with solid input shaft.

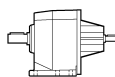

Getriebe mit zylindrischer Antriebswelle.

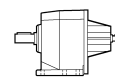

Réducteur avec arbre rapide Cylindrique.

**INFORMAZIONI GENERALI****GENERAL INFORMATION****ALLGEMEINEINFORMATIONEN****INFORMATIONS GENERALES****2 - COPPIA****2 - TORQUE****2 - ABTRIEBSMOMENT****2 - COUPLE****Coppia nominale**  
**M<sub>n2</sub> [Nm]**

È la coppia trasmissibile in uscita con carico continuo uniforme, riferita alla velocità in ingresso n<sub>1</sub> e a quella corrispondente in uscita n<sub>2</sub>.  
È calcolata in base ad un fattore di servizio f<sub>s</sub> = 1.

**Rated torque**  
**M<sub>n2</sub> [Nm]**

*The torque that can be transmitted continuously through the output shaft, with the gear unit operated under a service factor f<sub>s</sub> = 1.  
Rating is speed sensitive.*

**Nenn-Drehmoment**  
**M<sub>n2</sub> [Nm]**

Dies ist das an der Abtriebswelle übertragbare Drehmoment bei gleichförmiger Dauerbelastung bezogen auf die Antriebsdrehzahl n<sub>1</sub> und die entsprechende Abtriebsdrehzahl n<sub>2</sub>. Das Drehmoment wird auf Grundlage eines Betriebsfaktor f<sub>s</sub> = 1 berechnet.

**Couple nominal**  
**M<sub>n2</sub> [Nm]**

*C'est le couple transmissible en sortie avec une charge continue uniforme se référant à la vitesse en entrée n<sub>1</sub> et à celle correspondante en sortie n<sub>2</sub>. Il est calculé sur la base d'un facteur de service f<sub>s</sub> = 1.*

**Coppia richiesta**  
**M<sub>r2</sub> [Nm]**

Rappresenta la coppia richiesta dall'applicazione e dovrà sempre essere uguale o inferiore alla coppia in uscita nominale M<sub>n2</sub> del riduttore scelto.

**Required torque**  
**M<sub>r2</sub> [Nm]**

*The torque demand based on application requirement. It must always be equal to or less than torque M<sub>n2</sub> the gearbox under study is rated for.*

**Verlangtes Drehmoment**  
**M<sub>r2</sub> [Nm]**

Dies ist das von der Anwendung verlangte Drehmoment, das stets kleiner oder gleich dem Nenn-Abtriebsmoment M<sub>n2</sub> des gewählten Getriebes sein muß.

**Couple requis**  
**M<sub>r2</sub> [Nm]**

*Il représente le couple requis par l'application et devra toujours être inférieur ou égal au couple en sortie nominal M<sub>n2</sub> du réducteur choisi.*

**Coppia di calcolo**  
**M<sub>c2</sub> [Nm]**

È il valore di coppia da utilizzare per la selezione del riduttore considerando la coppia richiesta M<sub>r2</sub> e il fattore di servizio f<sub>s</sub> ed è dato dalla formula:

**Calculated torque**  
**M<sub>c2</sub> [Nm]**

*Computational torque value to be used when selecting the gearbox. It is calculated considering the required torque M<sub>r2</sub> and service factor f<sub>s</sub>, as per the equation here after:*

**Soll-Drehmoment**  
**M<sub>c2</sub> [Nm]**

Dies ist das bei der Wahl des Getriebes zugrundezulegende Drehmoment, wobei das übertragene Drehmoment M<sub>r2</sub> und der Betriebsfaktor f<sub>s</sub> zu berücksichtigen sind; das Soll-Drehmoment wird mit folgender Gleichung berechnet:

**Couple de calcul**  
**M<sub>c2</sub> [Nm]**

*C'est la valeur de couple à utiliser pour la sélection du réducteur en considérant le couple requis M<sub>r2</sub> et le facteur de service f<sub>s</sub> et s'obtient avec la formule:*

$$M_{c2} = M_{r2} \cdot f_s < M_{n2} \quad (1)$$

**3 - POTENZA****3 - POWER****3 - LEISTUNG****3 - PUISSANCE****Potenza nominale in entrata** P<sub>n1</sub> [kW]

Nelle tabelle di selezione dei riduttori è la potenza applicabile in entrata riferita alla velocità n<sub>1</sub>, considerando un fattore di servizio f<sub>s</sub> = 1.

**Rated power** P<sub>n1</sub> [kW]

*In the gearbox selection charts this is the power applicable to input shaft, based on input speed n<sub>1</sub> and corresponding to service factor f<sub>s</sub> = 1.*

**Leistung Antriebswelle** P<sub>n1</sub> [kW]

In den Tabellen für die Wahl der Getriebe ist die an der Antriebswelle übertragbare Leistung auf die Drehzahl n<sub>1</sub> bezogen und es wurde ein Betriebsfaktor f<sub>s</sub> = 1 angenommen.

**Puissance en entrée** P<sub>n1</sub> [kW]

*Dans les tableaux de sélection des réducteurs, c'est la puissance applicable en entrée se rapportant à la vitesse n<sub>1</sub> et en considérant un facteur de service f<sub>s</sub> = 1.*

**4 - POTENZA TERMICA** $P_t$  [kW]

$P_t$  è il valore che indica il limite termico del riduttore e rappresenta la potenza trasmissibile in servizio continuo, e alla temperatura ambiente  $t_a=20\text{ }^\circ\text{C}$ , senza che si producano danneggiamenti negli organi del riduttore o degradamenti del lubrificante. Vedi tab. (A1).

Nel caso di servizio intermittente, o di temperatura ambiente diversa da  $20\text{ }^\circ\text{C}$ , il valore di  $P_t$  deve essere corretto per mezzo del fattore  $f_t$ , espresso dalla tabella (A2), ossia  $P_t' = P_t \times f_t$ .

Infine, per riduttori con più di due riduzioni e/o con rapporto  $i > 45$  la verifica della potenza termica non è necessaria in quanto quest'ultima è certamente superiore alla potenza meccanica trasmissibile.

**4 - THERMAL CAPACITY** $P_t$  [kW]

$P_t$  is the power that can be transmitted through the gear unit, under a continuous duty and an ambient temperature of  $20\text{ }^\circ\text{C}$ , without resulting into damage of the inner parts or degradation of the lubricant properties. Refer to chart (A1) for specific kW ratings.

In case of intermittent duty, or an operating ambient temperature other than the rated  $20\text{ }^\circ\text{C}$ , the  $P_t$  value should be adjusted through the factor  $f_t$ , obtained from chart (A2), as per the following equation:  $P_t' = P_t \times f_t$ .

Gear units featuring more than 2 reductions and/or a gear ratio greater than  $i = 45$  do not normally require the thermal limit to be checked as in these cases the thermal rating usually exceeds the mechanical rating.

**4 - THERMISCHE GRENZ-LEISTUNG** $P_t$  [kW]

$P_t$  steht für den Wert der Wärmegrenzleistung des Getriebes und gibt die im Dauerbetrieb und bei einer Umgebungstemperatur  $t_a=20\text{ }^\circ\text{C}$  übertragbare Leistung an, ohne daß sich daraus Schäden an den Getriebeorganen oder ein Verfall des Schmiermittels ergeben. Siehe Tab. (A1). Bei einem Aussetzbetrieb oder bei verschiedener Umgebungstemperatur als  $20\text{ }^\circ\text{C}$  muß der Wert  $P_t$  über den Faktor  $f_t$  korrigiert werden, der in der Tabelle (A2) aufgeführt wird bzw.  $P_t' = P_t \times f_t$ .

Bei Getrieben mit mehr als zwei Untersetzungsstufen und/oder einem Verhältnis von  $i > 45$  ist die Kontrolle der thermischen Leistung nicht erforderlich, da sie sicher oben der mechanisch übertragbaren Leistung liegt.

**4 - PUISSANCE THERMIQUE** $P_t$  [kW]

$P_t$  est la valeur qui indique la limite thermique du réducteur et représente la puissance transmissible en service continu, et à une température ambiante  $t_a=20\text{ }^\circ\text{C}$ , sans apparition de dommages au niveau des organes du réducteur ou de dégradations du lubrifiant. Voir tab. (A1). En cas de service intermittent ou de température ambiante différente de  $20\text{ }^\circ\text{C}$ , la valeur de  $P_t$  doit être corrigée au moyen du facteur  $f_t$ , exprimé dans le tableau (A2), à savoir:  $P_t' = P_t \times f_t$ .

Enfin, pour les réducteurs ayant plus de deux réductions et/ou un rapport  $i > 45$ , la vérification de la puissance thermique n'est pas nécessaire car elle est certainement supérieure à la puissance mécanique transmissible.

(A1)

$P_t$ [kW] $20\text{ }^\circ\text{C}$		
	$n_1 = 1400\text{ min}^{-1}$	$n_1 = 2800\text{ min}^{-1}$
<b>C 05 2</b>	—	—
<b>C 11 2</b>	—	—
<b>C 21 2</b>	—	—
<b>C 31 2</b>	—	4.5
<b>C 35 2</b>	6.5	5.0
<b>C 41 2</b>	8.0	6.0
<b>C 51 2</b>	11.0	7.8
<b>C 61 2</b>	14.0	10.0
<b>C 70 2</b>	21	16.0
<b>C 80 2</b>	32	24
<b>C 90 2</b>	43	32
<b>C 100 2</b>	59	42

(A2)

$f_t$					
$t_a$ [ $^\circ\text{C}$ ]	Servizio continuo Continuous duty Dauerbetrieb Service continu	Servizio intermittente / Intermittent duty / Aussetzbetrieb / Service intermittent			
		Grado di intermittenza / Degree of intermittence / Relative Einschaltdauer / Degré d'intermittence			
		[ I ]			
		80%	60%	40%	20%
40	0.80	1.1	1.3	1.5	1.6
30	0.85	1.3	1.5	1.6	1.8
20	1.0	1.5	1.6	1.8	2.0
10	1.15	1.6	1.8	2.0	2.3



Il grado di intermittenza (I)% è dato dal rapporto fra il tempo di funzionamento a carico  $t_f$  e il tempo totale ( $t_f + t_r$ ), espresso in percentuale.

Where cyclic duration factor (I)% is the relationship of operating time under load  $t_f$  to total time ( $t_f + t_r$ ) expressed as a percentage.

Wobei die Einschaltdauer (I)% von dem Verhältnis zwischen Betriebszeit unter Last  $t_f$  und der Gesamtbetriebszeit ( $t_f + t_r$ ), ausgedrückt in Prozenten, gegeben wird.

Où le degré d'intermittence (I)% est fourni par le rapport entre le temps de fonction en charge et le temps total ( $t_f + t_r$ ) exprimé en pourcentage.

$$I = \frac{t_f}{t_f + t_r} \cdot 100 \quad (2)$$

La condizione da verificare è:

The condition to be verified is:

Die durchzuführende Kontrolle ist:

La vérification à faire sera la suivante:

$$P_{r1} \leq P_t \times f_i \quad (3)$$

**5 - RENDIMENTO**

**5 - EFFICIENCY**

**5 - WIRKUNGSGRAD**

**5 - RENDEMENT**

**Rendimento dinamico**  $\eta_d$

**Dynamic efficiency**  $\eta_d$

**Dynamischer Wirkungsgrad**  $\eta_d$

**Rendement dynamique**  $\eta_d$

È dato dal rapporto fra la potenza in uscita  $P_2$  e quella in entrata  $P_1$  secondo la relazione:

Obtained from the relationship of delivered power  $P_2$  to input power  $P_1$ , according to the following equation:

Er ist gegeben durch das Verhältnis der Abtriebsleistung  $P_2$  zur Antriebsleistung  $P_1$ :

Il est donné par le rapport entre la puissance en sortie  $P_2$  et celle en entrée  $P_1$ :

$$\eta_d = \frac{P_2}{P_1} \cdot 100 \quad [\%] \quad (4)$$

(A3)

	2 x	3 x	4 x
$\eta_d$	95%	93%	90%

**6 - RAPPORTO DI RIDUZIONE i**

**6 - GEAR RATIO i**

**6 - GETRIEBEÜBERSETZUNG i**

**6 - RAPPORT DE REDUCTION i**

Il valore del rapporto di riduzione della velocità, identificato con il simbolo [ i ], è espresso tramite il rapporto fra le velocità all'albero veloce e lento del riduttore e riassunto nell'espressione:

The value for the gear ratio is referred to with the letter [ i ] and calculated through the relationship of the input speed  $n_1$  to the output speed  $n_2$ :

Die Übersetzung des Getriebes wird mit dem Buchstaben [ i ] bezeichnet und ist folgendermaßen definiert:

Le rapport de réduction est identifiée par la lettre [ i ] et son calcul s'effectue à partir de la vitesse d'entrée  $n_1$  et de la vitesse de sortie  $n_2$  en utilisant la relation suivante :

$$i = \frac{n_1}{n_2} \quad (5)$$



Il rapporto di riduzione è solitamente un numero decimale che viene rappresentato nel catalogo con una sola cifra decimale, o nessuna nel caso di  $i > 1000$ .

Se si è interessati a conoscere il numero in tutte le componenti decimali consultare il Servizio Tecnico di Bonfiglioli Riduttori.

*The gear ratio is usually a decimal number which in this catalogue is truncated at one digit after the comma (no decimals for  $i > 1000$ ).*

*If interested in knowing the exact value please consult Bonfiglioli's Technical Service.*

In diesem Katalog wird die Übersetzung mit einer Stelle hinter dem Komma angegeben, bei Übersetzungen  $> 1000$  ohne Dezimalstelle.

Wenn genaue Angaben zur Übersetzung benötigt werden, wenden sie sich bitte an den technischen Service von Bonfiglioli Riduttori.

*Dans le catalogue, le rapport de réduction a une précision d'un chiffre après la virgule (sauf pour  $i > 1000$ ).*

*Si une plus grande précision est nécessaire, contacter le Service Technique de Bonfiglioli.*

## 7 - VELOCITÀ ANGOLARE

**Velocità in entrata**  
 $n_1$  [ $\text{min}^{-1}$ ]

È la velocità relativa al tipo di motorizzazione scelta; i valori di catalogo si riferiscono alle velocità dei motori elettrici comunemente usati a singola e doppia polarità.

Se il riduttore riceve il moto da una trasmissione in entrata, è sempre preferibile adottare velocità inferiori a  $1400 \text{ min}^{-1}$  al fine di garantire condizioni ottimali di funzionamento.

Velocità in entrata superiori sono ammesse considerando il naturale declassamento della coppia nominale  $M_{n2}$  del riduttore.

## 7 - ANGULAR VELOCITY

**Input speed**  
 $n_1$  [ $\text{min}^{-1}$ ]

*The speed is related to the prime mover selected. Catalogue values refer to speed of either single or double speed motors that are common in the industry.*

*If the gearbox is driven by an external transmission it is recommended to operate it with a speed of  $1400 \text{ min}^{-1}$ , or lower, in order to optimise operating conditions and lifetime.*

*Higher input speeds are permitted, however in this case consider that torque rating  $M_{n2}$  is affected adversely.*

*Please consult a Bonfiglioli representative.*

## 7 - DREHZAHL

**Drehzahl Antriebswelle**  
 $n_1$  [ $\text{min}^{-1}$ ]

Dies ist die vom gewählten Motortyp abhängige Drehzahl. Die Katalogangaben beziehen sich auf die Drehzahl von allgemein üblichen eintourigen Elektromotoren oder von polumschaltbaren Elektromotoren.

Um optimale Betriebsbedingungen zu gewährleisten, ist stets eine Antriebsdrehzahl unter  $1400 \text{ min}^{-1}$  zu empfehlen.

Höhere Antriebsdrehzahlen sind zulässig, wobei die zwangsläufige Herabsetzung des Nenn-Antriebsdrehmoments  $M_{n2}$  des Getriebes zu berücksichtigen ist.

## 7 - VITESSE ANGULAIRE

**Vitesse d'entrée**  
 $n_1$  [ $\text{min}^{-1}$ ]

*C'est la vitesse relative au type de motorisation choisie. Les valeurs de catalogue se réfèrent aux vitesses des moteurs électriques à simple et double polarité communément utilisés.*

*Si le réducteur reçoit le mouvement d'une transmission en entrée, il est toujours préférable d'adopter des vitesses inférieures à  $1400 \text{ min}^{-1}$  afin de garantir des conditions optimales de fonctionnement.*

*Des vitesses d'entrée supérieures sont admises en considérant le déclassement naturel du couple nominal  $M_{n2}$  du réducteur.*

**Velocità in uscita**  
 $n_2$  [ $\text{min}^{-1}$ ]

È in funzione della velocità in entrata  $n_1$  e del rapporto di riduzione  $i$  secondo la relazione:

**Output speed**  
 $n_2$  [ $\text{min}^{-1}$ ]

*The output speed value  $n_2$  is calculated from the relationship of input speed  $n_1$  to the gear ratio  $i$ , as per the following equation:*

**Abtriebsdrehzahl**  
 $n_2$  [ $\text{min}^{-1}$ ]

Sie ist abhängig von der Antriebsdrehzahl  $n_1$  und dem Übersetzungs  $i$  nach folgender Gleichung:

**Vitesse en sortie**  
 $n_2$  [ $\text{min}^{-1}$ ]

*Elle varie en fonction de la vitesse d'entrée  $n_1$  et du rapport de réduction  $i$  selon l'équation:*

$$n_2 = \frac{n_1}{i} \quad (6)$$

**8 - MOMENTO D'INERZIA**  
 $J_r$  [ $\text{Kgm}^2$ ]

I momenti d'inerzia indicati a catalogo sono riferiti all'asse di entrata del riduttore per cui, nel caso di accoppiamento diretto, sono già rapportati alla velocità del motore.

**8 - MOMENT OF INERTIA**  
 $J_r$  [ $\text{Kgm}^2$ ]

*Moments of inertia specified in the catalogue refer to the gear unit input axis. They are therefore related to motor speed, in the case of direct motor mounting.*

**8 - TRÄGHEITSMOMENT**  
 $J_r$  [ $\text{Kgm}^2$ ]

Die im Katalog angegebenen Trägheitsmomente sind auf die Antriebswelle des Getriebes bezogen und daher im Falle einer direkten Verbindung schon zur Motordrehzahl in Beziehung gesetzt.

**8 - MOMENT D'INERTIE**  
 $J_r$  [ $\text{Kgm}^2$ ]

*Les moments d'inertie indiqués dans le catalogue se réfèrent à l'axe d'entrée du réducteur par conséquent, dans le cas d'accouplement direct, ils se rapportent déjà à la vitesse du moteur.*



**9 - FATTORE DI SERVIZIO  $f_s$** **9 - SERVICE FACTOR  $f_s$** **9 - BETRIEBSFAKTOR  $f_s$** **9 - FACTEUR DE SERVICE  $f_s$** 

Il fattore di servizio è il parametro che traduce in un valore numerico la gravosità del servizio che il riduttore è chiamato a svolgere, tenendo conto, benché con inevitabile approssimazione, del funzionamento giornaliero, della variabilità del carico e di eventuali sovraccarichi, connessi con la specifica applicazione del riduttore.

Nel grafico (A4) più sotto riportato il fattore di servizio si ricava, dopo aver selezionato la colonna relativa alle ore di funzionamento giornaliere, per intersezione fra il numero di avviamenti orari e una fra le curve K1, K2 e K3.

Le curve K\_ sono associate alla natura del servizio (approssimativamente: uniforme, medio e pesante) tramite il fattore di accelerazione delle masse K, legato al rapporto fra le inerzie delle masse condotte e del motore.

Indipendentemente dal valore così ricavato del fattore di servizio, segnaliamo che esistono applicazioni fra le quali, a puro titolo di esempio i sollevamenti, per le quali il cedimento di un organo del riduttore potrebbe esporre il personale che opera nelle immediate vicinanze a rischio di ferimento.

Se esistono dubbi che l'applicazione possa presentare questa criticità vi invitiamo a consultare preventivamente il ns. Servizio Tecnico.

*This factor is the numeric value describing reducer service duty. It takes into consideration, with unavoidable approximation, daily operating conditions, load variations and overloads connected with reducer application.*

*In the graph (A4) below, after selecting proper "daily working hours" column, the service factor is given by intersecting the number of starts per hour and one of the K1, K2 or K3 curves.*

*K\_ curves are linked with the service nature (approximately: uniform, medium and heavy) through the acceleration factor of masses K, connected to the ratio between driven masses and motor inertia values.*

*Regardless of the value given for the service factor, we would like to remind that in some applications, which for example involve lifting of parts, failure of the reducer may expose the operators to the risk of injuries.*

*If in doubt, please contact our Technical Service Department.*

Beim Betriebsfaktor handelt es sich um den Parameter, der die Betriebsbelastung, die das Getriebe aushalten muss, in einem Wert ausdrückt. Dabei berücksichtigt er, auch wenn nur mit einer unvermeidbaren Annäherung, den täglichen Einsatz, die unterschiedlichen Belastungen und eventuelle Überbelastungen, die mit der spezifischen Applikation des Getriebes verbunden sind. Der nachstehenden Grafik (A4) kann, nach der Wahl der entsprechenden Spalte mit der Angabe der täglichen Betriebsstunden der Betriebsfaktor entnommen werden, indem man die Schnittstelle zwischen der stündlichen Schaltungen und einer der Kurven K1, K2 und K3 sucht. Die mit K\_ gekennzeichneten Kurven sind über den Beschleunigungsfaktor der Massen K an die Betriebsart gekoppelt (annähernd: gleichmäßige, mittlere oder starke Belastung), der wiederum an das Verhältnis zwischen Trägheitsmoment der angetriebenen Massen und dem des Motors gebunden ist. Unabhängig von dem so erhaltenen Betriebsfaktor, möchten wir Sie darauf hinweisen, dass es Applikationen gibt, unter denen beispielsweise auch die Hebefunktionen zu finden sind, bei denen das Nachgeben eines Getriebeorgans, das in dessen Nähe arbeitende Personal einer Verletzungsgefahr aussetzen könnte. Sollten daher Zweifel darüber bestehen, ob die entsprechende Applikation sich in diesem Bezug als kritisch erweist, bitten wir Sie sich zuvor mit unseren Technischen Kundendienst in Verbindung zu setzen.

*Le facteur de service est le paramètre qui traduit en une valeur numérique la difficulté du service que le réducteur est appelé à effectuer en tenant compte, avec une approximation inévitable, du fonctionnement journalier, de la variabilité de la charge et des éventuelles surcharges liées à l'application spécifique du réducteur.*

*Sur le graphique (A4) ci-dessous, le facteur de service peut être trouvé, après avoir sélectionné la colonne relative aux heures de fonctionnement journalier, à l'intersection entre le nombre de démarrages horaires et l'une des courbes K1, K2 et K3.*

*Les courbes K\_ sont associées à la nature du service (approximativement : uniforme, moyen et difficile) au moyen du facteur d'accélération des masses K, lié au rapport entre les inerties des masses conduites et le moteur.*

*Indépendamment de la valeur du facteur de service ainsi trouvée, nous signalons qu'il existe des applications parmi lesquelles, à titre d'exemple, les levages, pour lesquels la rupture d'un organe du réducteur pourrait exposer le personnel opérant à proximité immédiate à des risques de lésion.*

*En cas de doute concernant les risques éventuels de l'application, nous vous conseillons de contacter préalablement notre Service Technique.*

(A4)

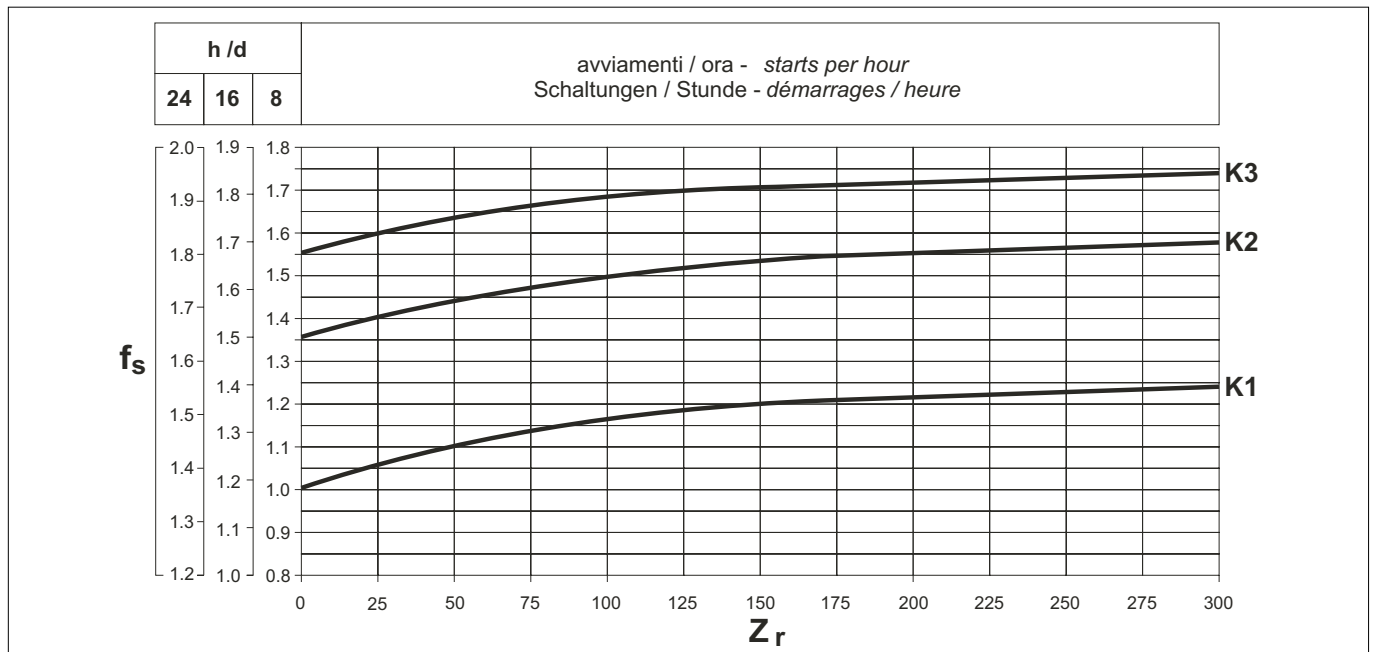

**Fattore di accelerazione delle masse, K****Acceleration factor of masses, K****Beschleunigungsfaktor der Massen, K****Facteur d'accélération des masses, K**

Il parametro serve a selezionare la curva relativa al particolare tipo di carico. Il valore è dato dal rapporto:

*This parameter serves for selecting the right curve for the type of load. The value is given by the following ratio:*

Dieser Parameter dient der Wahl der Kurve, die sich auf die jeweilige Belastungsart bezieht. Der Wert ergibt sich aus folgender Formel:

*Le paramètre sert à sélectionner la courbe relative au type de charge particulier. La valeur est obtenue par l'équation :*

$$K = \frac{J_c}{J_m} \quad (7)$$

dove:

where:

wobei:

où:

$J_c$  momento d'inerzia delle masse comandate, riferito all'albero del motore

$J_c$  *moment of inertia of driven masses referred to motor driving shaft*

$J_c$  Trägheitsmoment der angetriebenen Massen, bezogen auf die Motorwelle

$J_c$  *moment d'inertie des masses commandées se référant à l'arbre du moteur*

$J_m$  momento d'inerzia del motore

$J_m$  *moment of inertia of motor*

$J_m$  Trägheitsmoment des Motors

$J_m$  *moment d'inertie du moteur*

$K \leq 0.25$  – curva **K1**  
carico uniforme

$K \leq 0.25$  – curve **K1**  
*uniform load*

$K \leq 0.25$  – Kurve **K1**  
Gleichmäßige Belastung

$K \leq 0.25$  – courbe **K1**  
*charge uniforme*

$0.25 < K \leq 3$  – curva **K2**  
carico con urti moderati

$0.25 < K \leq 3$  – curve **K2**  
*moderate shock load*

$0.25 < K \leq 3$  – Kurve **K2**  
Belastung mit mäßigen Stößen

$0.25 < K \leq 3$  – courbe **K2**  
*charge avec chocs modérés*

$3 < K \leq 10$  – curva **K3**  
carico con forti urti

$3 < K \leq 10$  – curve **K3**  
*heavy shock load*

$3 < K \leq 10$  – Kurve **K3**  
Belastung mit starken Stößen

$3 < K \leq 10$  – courbe **K3**  
*charge avec chocs importants*

Per valori di  $K > 10$  invitiamo a consultare il nostro Servizio Tecnico.

*For K values > 10, please contact our Technical Service.*

Bei Werten  $K > 10$  bitten wir Sie, sich mit unserem Technischen Kundendienst in Verbindung zu setzen.

*Pour des valeurs de K > 10, nous vous conseillons de contacter notre Service Technique.*

**10 - MANUTENZIONE****10 - MAINTENANCE****10 - WARTUNG****10 - ENTRETIEN**

I riduttori forniti con lubrificazione permanente non necessitano di sostituzioni periodiche dell'olio.

*Life lubricated gearboxes do not require any periodical oil changes.*

Die mit Dauerschmierung gelieferten Getriebe bedürfen periodische Ölwechsel.

*Les réducteurs fournis avec lubrification permanente n'ont besoin d'aucun remplacement périodique de huile.*

Per gli altri si consiglia di effettuare una prima sostituzione del lubrificante dopo circa 300 ore di funzionamento provvedendo ad un accurato lavaggio interno del gruppo con adeguate detergenti.

*For other types of gearboxes, the first oil change must take place after about 300 hours of operation, carefully flushing the gear unit using suitable detergents.*

Bei den übrigen Getrieben wird ein erster Ölwechsel nach ca. 300 Betriebsstunden empfohlen, wobei das Innere der Gruppe sorgfältig mit einem geeigneten Reinigungsmittel zu waschen ist.

*Pour les autres, nous conseillons d'effectuer une première vidange du lubrifiant après les 300 premières heures de fonctionnement en réalisant un lavage soigné à l'intérieur du groupe avec des produits détergents appropriés.*

Evitare di miscelare olii a base minerale con olii sintetici.

*Do not mix mineral oils with synthetic oils.*

Mineralöle nicht mit Syntheseölen mischen.

*Eviter de mélanger les huiles à base minérale avec des huiles synthétiques.*

Controllare periodicamente il livello del lubrificante effettuando la sostituzione indicativamente agli intervalli riportati nella tabella (A5).

*Check oil level regularly and change oil at the intervals shown in the table (A5).*

Den Ölstand regelmäßig kontrollieren. Die Ölwechsel in den in der Tabelle (A5) angegebenen Fristen durchführen.

*Contrôler périodiquement le niveau du lubrifiant en effectuant les vidanges conformément aux intervalles indiqués dans le tableau (A5).*

(A5)

Temperatura olio / Oil temperature Öltemperatur / Température huile [°C]	Intervallo di lubrificazione / Oil change interval Schmierfrist / Intervalle de lubrification [h]	
	olio minerale / mineral oil Mineralöl / huile minérale	olio sintetico / synthetic oil Syntheseöl / huile synthétique
< 65	8000	25000
65 - 80	4000	15000
80 - 95	2000	12500



11 - SELEZIONE

11 - SELECTION

11 - ANTRIEBSAUSWAHL

11 - SELECTION

Per selezionare correttamente un riduttore o un motorriduttore, è necessario disporre di alcuni dati fondamentali che sono sintetizzati nella tabella (A6). In particolare, essa potrà essere compilata ed inviata in copia al ns. Servizio Tecnico che provvederà alla ricerca della motorizzazione più idonea alla applicazione indicata.

Some fundamental data are necessary to assist the correct selection of a gearbox or gearmotor. The table below (A6) briefly sums up this information. To simplify selection, fill in the table and send a copy to our Technical Service which will select the most suitable drive unit for your application.

Um die Getriebe und Getriebe-motoren richtig auszuwählen zu können, muß man über einige grundlegende Daten verfügen, die wir in der Tabelle (A6) zusammengefaßt haben. Eine Kopie dieser vom Kunden ausgefüllten Tabelle kann an unseren Technischen Kundendienst geschickt werden, der dann die für die gewünschte Anwendung geeignete Auslegung wählt.

Pour sélectionner correctement un réducteur ou un motoréducteur, il est nécessaire de disposer de certaines données fondamentales que nous avons résumé dans le tableau (A6). En particulier, ce dernier pourra être rempli et retourné à notre service technique qui recherchera la motorisation la plus appropriée à l'application indiquée.

(A6)

Tipo di applicazione <i>Type of application</i> Anwendung <i>Type d'application</i>			
P <sub>2</sub>	Potenza in uscita a n <sub>2</sub> max <i>Output power at n<sub>2</sub> max</i> Abtriebsleistung bei n <sub>2</sub> max <i>Puissance en sortie à n<sub>2</sub> maxi</i>	.....kW	Senso di rotazione albero entrata (O-AO) (**) <i>Input shaft rotation direction (CW-CCW) (**)</i> Drehrichtung der Antriebswelle (U-GU) (**) <i>Sens de rotation arbre entrée (H-AH) (**)</i>
P <sub>2</sub> '	Potenza in uscita a n <sub>2</sub> min <i>Output power at n<sub>2</sub> min</i> Abtriebsleistung bei n <sub>2</sub> min <i>Puissance en sortie à n<sub>2</sub> mini</i>	.....kW	A <sub>c1</sub> Carico assiale su albero in uscita (+/-)(***) <i>Thrust load on output shaft (+/-)(***)</i> Axialkraft auf Abtriebswelle (+/-)(***) <i>Charge axiale sur arbre de sortie (+/-)(***)</i>
M <sub>2</sub>	Momento torcente in uscita a n <sub>2</sub> max <i>Output torque at n<sub>2</sub> max</i> Abtriebsdrehmoment bei n <sub>2</sub> max <i>Moment de torsion en sortie à n<sub>2</sub> maxi</i>	.....Nm	A <sub>c1</sub> Carico assiale su albero in entrata (+/-)(***) <i>Thrust load on input shaft (+/-)(***)</i> Axialkraft auf Antriebswelle (+/-)(***) <i>Charge axiale sur arbre d'entrée (+/-)(***)</i>
n <sub>2</sub>	Velocità di rotazione in uscita max <i>Max.output speed</i> Abtriebsdrehzahl max <i>Vitesse de rotation maxi en sortie</i>	.....min <sup>-1</sup>	J <sub>c</sub> Momento d'inerzia del carico <i>Moment of inertia of the load</i> Trägheitsmoment der Last <i>Moment d'inertie de la charge</i>
n <sub>2</sub> '	Velocità di rotazione in uscita min <i>Min.output speed</i> Abtriebsdrehzahl min <i>Vitesse de rotation mini en sortie</i>	.....min <sup>-1</sup>	t <sub>a</sub> Temperatura ambiente <i>Ambient temperature</i> Umgebungstemperatur <i>Température ambiante</i>
n <sub>1</sub>	Velocità di rotazione in entrata max <i>Max.input speed</i> Antriebsdrehzahl max <i>Vitesse de rotation maxi en entrée</i>	.....min <sup>-1</sup>	Alteitudine sul livello del mare <i>Altitude above sea level</i> Höhe ü.d.M. <i>Altitude au-dessus du niveau de la mer</i>
n <sub>1</sub> '	Velocità di rotazione in entrata min <i>Min.input speed</i> Antriebsdrehzahl min <i>Vitesse de rotation mini en entrée</i>	.....min <sup>-1</sup>	Tipo di servizio in accordo a CEI <i>Duty type to IEC norms</i> Relative Einschaltdauer gemäß CEI <i>Type de service selon CE</i>
R <sub>c2</sub>	Carico radiale su albero in uscita <i>Radial load on output shaft</i> Radialkraft auf Abtriebswelle <i>Charge radiale sur arbre de sortie</i>	.....N	Z Frequenza di avviamento <i>Starting frequency</i> Schaltungshäufigkeit <i>Fréquence de démarrage</i>
x <sub>2</sub>	Distanza di applicazione del carico (*) <i>Load application distance (*)</i> Abstand des Kraftangriffspunktes (*) <i>Distance d'application de la charge (*)</i>	.....mm	Tensione di alimentazione motore <i>Motor voltage</i> Nennspannung des Motors <i>Tension de alimentation moteur</i>
	Orientamento del carico in uscita <i>Load orientation at output</i> Orientierung der Last am Abtrieb <i>Orientation de la charge en sortie</i>		Tensione di alimentazione freno <i>Brake voltage</i> Nennspannung der Bremse <i>Tension de alimentation frein</i>
	Senso di rotazione albero uscita (O-AO) (**) <i>Output shaft rotation direction (CW-CCW) (**)</i> Drehrichtung der Abtriebswelle (U-GU) (**) <i>Sens de rotation arbre sortie (H-AH) (**)</i>	.....	Frequenza <i>Frequency</i> Frequenz <i>Fréquence</i>
R <sub>c1</sub>	Carico radiale su albero in entrata <i>Radial load on input shaft</i> Radialkraft auf Antriebswelle <i>Charge radiale sur arbre d'entrée</i>	.....N	M <sub>b</sub> Coppia frenante <i>Brake torque</i> Bremsmoment <i>Couple de freinag</i>
x <sub>1</sub>	Distanza di applicazione del carico (*) <i>Load application distance (*)</i> Abstand des Kraftangriffspunktes (*) <i>Distance d'application de la charge (*)</i>	.....mm	Grado di protezione motore <i>Motor protection degree</i> Schutzart des Motors <i>Degré de protection moteur</i>
	Orientamento del carico in entrata <i>Load orientation at input</i> Orientierung der Last am Antrieb <i>Orientation de la charge en entrée</i>		Classe di isolamento <i>Insulation class</i> Isolierstoffklasse <i>Classe d'isolation</i>

(\*) La distanza x<sub>1-2</sub> è quella compresa fra il punto di applicazione della forza e la battuta dell'albero (se non indicata, si considererà la forza agente sulla mezziera della sporgenza dell'albero).  
 (\*\*) O = orario  
 AO = antiorario  
 (\*\*\*) + = compressione  
 - = trazione

(\*) Distance x<sub>1-2</sub> is between force application point and shaft shoulder (if not indicated the force acting at mid-point of the shaft extension will be considered).  
 (\*\*) CW = clockwise;  
 CCW = counterclockwise  
 (\*\*\*) + = push  
 - = pull

(\*) Der Abstand x<sub>1-2</sub> ist der Abstand vom Kraftangriffspunkt zum Wellenansatz (wenn nicht anders angegeben, wird davon ausgegangen, daß die Kraft auf der Mitte des Wellenendes angreift).  
 (\*\*) U = Uhrzeigersinn;  
 GU = Gegenurzeigersinn  
 (\*\*\*) + = Druck  
 - = Zug

(\*) La distance x<sub>1-2</sub> est celle comprise entre le point d'application de la force et l'épaulement de l'arbre (si non précisée l'on considerera la force agissant au milieu de la saillie de l'arbre).  
 (\*\*) H = sens horaire;  
 AH = sens antihoraire  
 (\*\*\*) + = compression  
 - = traction



<b>Scelta dei motoriduttori</b>	<b>Selection of a gearmotor</b>	<b>Wahl des Getriebemotors</b>	<b>Sélection des motoréducteurs</b>
---------------------------------	---------------------------------	--------------------------------	-------------------------------------

- |   |   |   |   |
|---|---|---|---|
| <p>a) Determinare il fattore di servizio <math>f_s</math> in funzione del tipo di carico (fattore K), del numero di inserzioni/ora <math>Z_r</math> e del numero di ore di funzionamento.</p> <p>b) Dalla coppia <math>M_{r2}</math>, conoscendo <math>n_2</math> e il rendimento dinamico <math>\eta_d</math>, ricavare la potenza in entrata.</p> | <p>a) <i>Determine service factor <math>f_s</math> according to type of duty (factor K), number of starts per hour <math>Z_r</math> and hours of operation.</i></p> <p>b) <i>From values of torque <math>M_{r2}</math>, speed <math>n_2</math> and efficiency <math>\eta_d</math> the required input power can be calculated from the equation:</i></p> | <p>a) Den Betriebsfaktor <math>f_s</math> in Abhängigkeit von der Belastungsart (Faktor K), den Schaltungen /Stunde <math>Z_r</math> und den Betriebsstunden bestimmen.</p> <p>b) Aus dem Drehmoment <math>M_{r2}</math> mit Hilfe der bekannten Werte für <math>n_2</math> und dem dynamischen Wirkungsgrad <math>\eta_d</math> die Antriebsleistung ableiten.</p> | <p>a) <i>Déterminer le facteur de service <math>f_s</math> en fonction du type de charge (facteur K), du nombre d'insertions/heure <math>Z_r</math> et du nombre d'heures de fonctionnement.</i></p> <p>b) <i>A partir du couple <math>M_{r2}</math>, en connaissant <math>n_2</math> et le rendement dynamique <math>\eta_d</math>, calculer la puissance en entrée.</i></p> |
|---|---|---|---|

$P_{r1} = \frac{M_{r2} \cdot n_2}{9550 \cdot \eta_d} \quad [\text{kW}] \quad (8)$
---

- |  |   |  |  |
|--|---|--|--|
| <p>Il valore di <math>\eta_d</math> per lo specifico riduttore può essere ricavato dal paragrafo 5.</p> <p>c) Ricercare fra le tabelle dei dati tecnici motoriduttori quella corrispondente ad una potenza normalizzata <math>P_n</math> tale che:</p> | <p><i>Value of <math>\eta_d</math> for the captioned worm gear can be sorted out from paragraph 5.</i></p> <p>c) <i>Consult the gearmotor selection charts and locate the table corresponding to normalised power <math>P_n</math>:</i></p> | <p>Für das spezifische Getriebe kann der Wert <math>\eta_d</math> unter Paragraph 5 erhoben werden.</p> <p>c) Unter den Tabellen mit den Technischen Daten der Getriebemotoren die Tabelle auswählen, die folgender Leistung entspricht:</p> | <p><i>Il valeur de <math>\eta_d</math> pour le réducteur spécifique peut être calculée d'après les indications du paragraphe 5.</i></p> <p>c) <i>Rechercher parmi les tableaux des caractéristiques techniques des motoréducteurs celui correspondant à une puissance:</i></p> |
|--|---|--|--|

$P_n \geq P_{r1} \quad (9)$
-----------------------------

- |  |  |   |   |
|--|--|---|---|
| <p>Se non diversamente indicato, la potenza <math>P_n</math> dei motori riportata a catalogo si riferisce al servizio continuo S1. Per i motori utilizzati in condizioni diverse da S1, sarà necessario identificare il tipo di servizio previsto con riferimento alle Norme CEI 2-3/IEC 34-1. In particolare, per i servizi da S2 a S8 e per le grandezze motore uguali o inferiori a 132, è possibile ottenere una maggiorazione della potenza rispetto a quella prevista per il servizio continuo, pertanto la condizione da soddisfare sarà:</p> | <p><i>Unless otherwise specified, power <math>P_n</math> of motors indicated in the catalogue refers to continuous duty S1. For motors used in conditions other than S1, the type of duty required by reference to CEI 2-3/IEC 34-1 Standards must be mentioned. For duties from S2 to S8 in particular and for motor frame 132 or smaller, extra power output can be obtained with respect to continuous duty. Accordingly the following condition must be satisfied:</i></p> | <p>Wenn nicht anders angegeben, bezieht sich die im Katalog angegebene Leistung <math>P_n</math> der Motoren auf Dauerbetrieb S1. Bei Motoren, die unter anderen Bedingungen als S1 eingesetzt werden, muß die vorgesehen Betriebsart unter Bezug auf die CEI-Normen 2-3/IEC 34-1 bestimmt werden. Insbesondere kann man für die Betriebsarten S2 bis S8 (und für Motorbaugrößen gleich oder niedriger als 132) eine Überdimensionierung der Leistung relativ zu der für den Dauerbetrieb vorgesehenen Leistung erhalten; die zu erfüllende Bedingung ist dann:</p> | <p><i>Sauf indication contraire la puissance <math>P_n</math> des moteurs indiquée dans le catalogue se réfère à un service continu S1. Pour les moteurs utilisés dans des conditions différentes du service S1, il sera nécessaire d'identifier le type de service prévu en se référant aux normes CEI 2-3/IEC 34-1. En particulier, pour les services de type S2 à S8 ou pour les tailles de moteurs égales ou inférieures à 132 il est possible d'obtenir une majoration de la puissance par rapport à celle prévue pour le service continu. Par conséquent, la condition à satisfaire sera:</i></p> |
|--|--|---|---|

$P_n \geq \frac{P_{r1}}{f_m} \quad (10)$
--

- |  |  |  |   |
|--|--|--|---|
| <p>Il fattore di maggiorazione <math>f_m</math> è ricavabile dalla tabella (A7).</p> | <p><i>The adjusting factor <math>f_m</math> can be obtained from table (A7).</i></p> | <p>Der Überdimensionierungsfaktor <math>f_m</math> kann der Tabelle (A7) entnommen werden.</p> | <p><i>Le facteur de majoration <math>f_m</math> peut être obtenu en consultant le tableau (A7).</i></p> |
|--|--|--|---|



**Rapporto di intermittenza**

**Intermittence ratio**

**Relative Einschaltdauer**

**Rapport d'intermittenza**

$$I = \frac{t_f}{t_f + t_r} \cdot 100 \quad (11)$$

$t_f$  = tempo di funzionamento a carico costante  
 $t_r$  = tempo di riposo

$t_f$  = work time at constant load  
 $t_r$  = rest time

$t_f$  = Betriebszeit mit konstanter Belastung  
 $t_r$  = Aussetzzeit

$t_f$  = temps de fonctionneent à charge constante  
 $t_r$  = temps de repos

(A7)

	SERVIZIO / DUTY / BETRIEB / SERVICE						
	S2			S3*			S4 - S8
	Durata del ciclo / Cycle duration [min] Zyklusdauer / Durée du cycle [min]			Rapporto di intermittenza / Cyclic duration factor (I) Relative Einschaltdauer / Rapport d'intermittenza (I)			
$f_m$	10	30	60	25%	40%	60%	Interpellarci Please contact us Rückfrage Nous contacter
	1.35	1.15	1.05	1.25	1.15	1.1	

\* La durata del ciclo dovrà comunque essere uguale o inferiore a 10 minuti; se superiore interpellare il Servizio Tecnico di Bonfiglioli Riduttori.

\* Cycle duration, in any event, must be 10 minutes or less. If it is longer, please contact our Technical Service.

\* Die Zyklusdauer muß in jedem Fall kleiner oder gleich 10 min sein; wenn sie darüber liegt, unseren Technisch en Kundendienst zu Rate ziehen.

\* La durée du cycle devra être égale ou inférieure à 10 minutes. Si supérieure, contacter notre Service Technique.

Nella sezione relativa alla potenza installata  $P_n$  selezionare infine il motoriduttore che sviluppa la velocità di funzionamento più prossima alla velocità  $n_2$  desiderata e per il quale il fattore di sicurezza  $S$  sia uguale, o superiore, al fattore di servizio  $f_s$ .

Next, refer to the appropriate  $P_n$  section within the gearmotor selection charts and locate the unit that features the desired output speed  $n_2$ , or closest to, along with a safety factor  $S$  that meets or exceeds the applicable service factor  $f_s$ .

Als nächstes wählen Sie anhand der Getriebemotoren auswahltabellen den Abschnitt mit der entsprechenden  $P_n$  und suchen die gewünschte Abtriebsdrehzahl  $n_2$ , oder die nächstmögliche Drehzahl, zusammen mit dem Sicherheitsfaktor  $S$ , der den zutreffenden Betriebsfaktor  $f_s$  erreicht oder überschreitet. Der Sicherheitsfaktor wird wie folgt berechnet:

Dans la section relative à la puissance installée  $P_n$  sélectionner enfin le motoréducteur qui développe la vitesse de fonctionnement la plus proche à la vitesse  $n_2$  désirée et pour lequel le facteur de sécurité  $S$  soit pareil, ou supérieur, au facteur de service  $f_s$ .

Il fattore di sicurezza è così definito:

The safety factor is so defined:

Le facteur de sécurité est défini ainsi:

$$S = \frac{Mn_2}{M_2} = \frac{Pn_1}{P_1} \quad (12)$$

Nelle tabelle di selezione motoriduttori gli abbinamenti sono sviluppati con motori a 2, 4 e 6 poli alimentati a 50 Hz. Per velocità di comando diverse da queste, effettuare la selezione con riferimento ai dati nominali forniti per i riduttori.

As standard, gear and motor combinations are implemented with 2, 4 and 6 pole motors, 50 Hz supplied. Should the drive speed be different from 2800, 1400 or 900 min-1, base the selection on the gear unit nominal rating.

Standardmäßig stehen Getriebemotorenkombinationen mit 2, 4 und 6 poligen Motoren für eine Frequenz von 50 Hz zur Verfügung. Sollten die Antriebsdrehzahlen abweichend von 2800, 1400 oder 900 min-1 sein, dann stützen Sie die Auslegung des Getriebes auf die Getriebeenddaten.

Dans les tableaux de sélection des motoréducteurs les accouplements sont développés avec moteurs à 2, 4 et 6 poles alimentés à 50 Hz. Pour vitesses de commande différentes à celles-ci, sélectionner suite aux données nominales fournies par les réducteurs.

**Scelta dei riduttori e dei riduttori predisposti per motori IEC**

**Selection of speed reducer and gearbox with IEC motor adapter**

**Wahl des Getriebes und Getriebe für IEC-motoren**

**Sélection des réducteurs et des réducteurs CEI**

- a) Determinare il fattore di servizio  $f_s$ .
- b) Conoscendo la coppia  $M_{r2}$  di uscita richiesta dalla applicazione, si procede alla definizione della coppia di calcolo:

- a) Determine service factor  $f_s$ .
- b) Assuming the required output torque for the application  $M_{r2}$  is known, the calculation torque can be then defined as:

- a) Den Betriebsfaktor  $f_s$  bestimmen.
- b) Anhand des bekannten von der Anwendung geforderten Abtriebsdrehmoments  $M_{r2}$  das Soll-Drehmoment bestimmen:

- a) Déterminer le facteur de service  $f_s$ .
- b) En connaissant le couple  $M_{r2}$  de sortie requis par l'application, l'on procède à la définition du couple de calcul:

$$M_{c2} = M_{r2} \cdot f_s \quad (13)$$



c) In base alla velocità in uscita  $n_2$  richiesta, e a quella in entrata  $n_1$  disponibile, si calcola il rapporto di riduzione:

c) *The gear ratio is calculated according to requested output speed  $n_2$  and drive speed  $n_1$ :*

c) Auf Grundlage der verlangten Abtriebsdrehzahl  $n_2$  und der verfügbaren Antriebsdrehzahl  $n_1$  die Übersetzungs berechnen:

c) *Suivant la vitesse en sortie  $n_2$  requise et celle en entrée  $n_1$  disponible, l'on calcule le rapport de réduction:*

$$i = \frac{n_1}{n_2} \quad (14)$$

Disponendo dei dati  $M_{c2}$  e  $i$ , si ricercherà nelle tabelle corrispondenti alla velocità  $n_1$  il riduttore che, in funzione del rapporto  $[i]$  più prossimo a quello calcolato, proponga una coppia nominale:

*Once values for  $M_{c2}$  and  $i$  are known consult the rating charts under the appropriate input speed  $n_1$  and locate the gear unit that features the gear ratio closest to  $[i]$  and at same time offers a rated torque value  $M_{n2}$  so that:*

Anhand der Werte für  $M_{c2}$  und  $i$  in den Tabellen für die Drehzahl  $n_1$  das Getriebe auswählen, das in Abhängigkeit von einer Übersetzung  $[i]$ , die dem Sollwert möglichst nahe ist, folgendes Nenn-Drehmoment erlaubt:

*En disposant des données  $M_{c2}$  et  $i$ , l'on recherchera dans les tableaux correspondant à la vitesse  $n_1$  le réducteur qui, en fonction du rapport  $[i]$  le plus proche de celui calculé, propose un couple nominal:*

$$M_{n2} \geq M_{c2} \quad (15)$$

Se al riduttore scelto dovrà essere applicato un motore elettrico verificarne l'applicabilità consultando la tabella delle predisposizioni possibili al paragrafo 26.

*If a IEC normalized motor must be fitted check geometrical compatibility with the gear unit at paragraph 26 - Motor availability.*

Wenn das Getriebe mit einem Elektromotor verbunden werden soll, die Verträglichkeit anhand der Tabelle der möglichen Anbaumöglichkeiten sicherstellen.

*Au cas où il serait nécessaire d'appliquer un moteur électrique normalisé au réducteur choisi, en vérifier la possible adaptation en consultant le tableau des prédispositions possibles présenté.*

## 12 - VERIFICHE

## 12 - VERIFICATION

## 12 - PRÜFUNGEN

## 12 - VERIFICATIONS

Effettuata la selezione del riduttore, o motoriduttore, è opportuno procedere alle seguenti verifiche:

*After the selection of the speed reducer, or gearmotor, is complete it is recommended that the following verifications are conducted:*

Nachdem die Auswahl des Getriebe oder Getriebemotor abgeschlossen ist, werden die folgenden Schritte empfohlen:

*Une fois effectuée la sélection du réducteur, ou motoréducteur, il faut procéder aux suivantes vérifications:*

**Se si è selezionato un riduttore fra i tipi C112, C212 e C312 con rapporto  $i > 40$ , azionato con un numero di avviamenti orari  $Z > 30$ , correggere il fattore di servizio ricavato dal grafico (A4) moltiplicandolo per 1,2. Verificare infine nuovamente che per il nuovo valore di  $fs$  la condizione  $S \geq fs$  sia ancora verificata.**

***For gear units type C112, C212 and C312, with ratio  $i > 40$ , operated with  $Z > 30$  switches per hour, adjust the service factor calculated through diagram (A4) and multiply the value by 1.2. Thenafter check that for the revised service factor the condition  $S \geq fs$  still applies.***

**Für Getriebeeinheiten Type C112, C212 und C312 mit Untersetzung  $i > 40$ , bei einer drehzahl von Anlaufvorgängen  $Z > 30$ , korrigiere den Servicefaktor, errechnet aus Diagramm (A4), und multipliziere den Wert mit 1,2. Danach überprüfen für den neu erhaltenen Servicefaktor, ob die Bedingung  $S \geq fs$  noch zutrifft.**

***Si un réducteur parmi les types C112, C212 et C312 a été sélectionné avec rapport  $i > 40$ , actionné avec un nombre de démarrage horaires  $Z > 30$ , corriger le facteur de service tiré du graphique (A4) en le multipliant pour 1,2. Vérifier finalement que pour la nouvelle valeur  $fs$ , la condition  $S \geq fs$  soit encore vérifiée.***

a) Potenza termica

a) *Thermal capacity*

a) *Thermische Grenzleistung*

a) *Puissance thermique*

Assicurarsi che la potenza termica del riduttore, abbia un valore uguale o maggiore alla potenza richiesta dall'applicazione secondo la relazione (3) a pag. 6, in caso contrario selezionare un riduttore di grandezza superiore oppure provvedere ad applicare un sistema di raffreddamento forzato.

*Make sure that the thermal capacity of the gearbox is equal to or greater than the power required by the application according to equation (3) on page 6. If this condition is not verified, select a larger gearbox or apply a forced cooling system.*

Sicherstellen, daß die Wärmeleistung des Getriebes größer oder gleich der verlangten Leistung ist, die von der Anwendung nach Gleichung (3) auf S. 6 verlangt wird. Andernfalls ein größer dimensioniertes Getriebe wählen bzw. ein Zwangskühlsystem vorsehen.

*S'assurer que la puissance thermique du réducteur ait une valeur supérieure ou égale à la puissance requise par l'application selon l'équation (3) page 6. Dans le cas contraire, sélectionner un réducteur de taille supérieure ou bien prévoir un système de refroidissement forcé.*



b) Coppia massima

Generalmente la coppia massima (intesa come punta di carico istantaneo) applicabile al riduttore non deve superare il 200% della coppia nominale  $M_{n2}$ ; verificare pertanto che tale limite non venga superato adottando, se necessario, opportuni dispositivi per la limitazione della coppia. Per i motori trifase a doppia polarità è necessario rivolgere particolare attenzione alla coppia di commutazione istantanea che viene generata durante la commutazione dall'alta velocità alla bassa in quanto può essere decisamente più elevata della coppia massima stessa. Un metodo semplice ed economico per ridurre tale coppia è quello di alimentare solo due fasi del motore durante la commutazione (il tempo di alimentazione a due fasi può essere regolato mediante un relè a tempo):

$M_{g2} = 0.5 \cdot M_{g3}$   
 $M_{g2}$  = Coppia di commutazione alimentando 2 fasi  
 $M_{g3}$  = Coppia di commutazione alimentando 3 fasi

Suggeriamo comunque di contattare il ns. Servizio Tecnico.

b) Maximum torque

*The maximum torque (intended as instantaneous peak load) applicable to the gearbox must not, in general, exceed 200% of rated torque  $M_{n2}$ . Therefore, check that this limit is not exceeded, using suitable torque limiting devices, if necessary.*  
*For three-phase double speed motors, it is important to pay attention to the switching torque which is generated when switching from high to low speed, because it could be significantly higher than maximum torque.*  
*A simple, economical way to minimize overloading is to power only two phases of the motor during switch-over (power-up time on two phases can be controlled with a time-relay):*

$M_{g2} = 0.5 \cdot M_{g3}$   
 $M_{g2}$  = Switching torque with two-phase power-up  
 $M_{g3}$  = Switching torque with three-phase power-up

*We recommend, in any event, to contact our Technical Service.*

b) Max. Drehmoment

Im allgemeinen darf das max. Drehmoment (verstanden als momentane Lastspitze), das auf das Getriebe aufgebracht werden kann, 200 % des Nenndrehmoments  $M_{n2}$  nicht überschreiten. Sicherstellen, daß dieser Grenzwert nicht überschritten wird, und nötigenfalls die entsprechenden Vorrichtungen zur Begrenzung des Drehmoments vorsehen. Bei polumschaltbaren Drehstrommotoren muss dem Umschaltmoment, das beim Umschalten von der hohen auf die niedrige Drehzahl erzeugt wird, besondere Aufmerksamkeit geschenkt werden, da es entschieden größer sein kann als das Nenn-Drehmoment. Eine einfache und kostengünstige Methode zum Senken dieses Drehmoments besteht darin, daß nur zwei Phasen des Motors während des Umschaltens gespeist werden (die Dauer der Speisung von nur 2 Phasen kann durch ein Zeitrelais gesteuert werden):

$M_{g2} = 0.5 \cdot M_{g3}$   
 $M_{g2}$  = Umschaltmoment bei Speisung von 2 Phasen;  
 $M_{g3}$  = Umschaltmoment bei Speisung von 3 Phasen

Wir empfehlen jedoch in jedem Fall, unseren Technischen Kundendienst zu Rate zu ziehen.

b) Couple maximum

*Généralement, le couple maximum (à considérer comme une pointe de charge instantanée) applicable au réducteur ne doit pas dépasser les 200% du couple nominal  $M_{n2}$ . Vérifier par conséquent que cette limite ne soit pas dépassée en adoptant, si nécessaire, des dispositifs adaptés pour limiter le couple.*  
*Pour les moteurs triphasés à double polarité, il est nécessaire de prêter une attention particulière au couple de commutation instantané qui est généré lors du passage de la grande à la petite vitesse étant donné qu'il peut être considérablement plus élevé que le couple maximum lui même.*  
*Une méthode simple et économique pour réduire ce couple consiste à alimenter seulement deux phases du moteur pendant la commutation (la durée d'alimentation sur deux phases peut être réglée au moyen d'un relais temporisateur):*

$M_{g2} = 0.5 \cdot M_{g3}$   
 $M_{g2}$  = Couple de commutation en alimentant deux phases  
 $M_{g3}$  = Couple de commutation en alimentant trois phases

*Nous suggérons cependant de contacter notre Service Technique.*

c) Carichi radiali

Verificare che i carichi radiali agenti sugli alberi di entrata e/o uscita rientrino nei valori di catalogo ammessi. Se superiori, aumentare la grandezza del riduttore oppure modificare la supportazione del carico. Ricordiamo che tutti i valori indicati nel catalogo si riferiscono a carichi agenti sulla mezziera della sporgenza dell'albero in esame per cui, in fase di verifica, è indispensabile tenere conto di questa condizione provvedendo, se necessario, a determinare con le apposite formule il carico ammissibile alla distanza  $x_{1,2}$  desiderata. A tale proposito si rimanda ai paragrafi relativi ai carichi radiali.

c) Radial loads

*Make sure that radial forces applying on input and/or output shaft are within permittend catalogue values. If they were higher consider designing a different bearing arrangement before switching to a larger gear unit.*  
*Catalogue values for rated overhung loads refer to mid-point of shaft under study.*  
*Should application point of the overhung load be localised further out the revised loading capability must be adjusted as per instructions given in this manual. See paragraph 22.*

c) Radialkräfte

Sicherstellen, daß die auf die Antriebswellen und/oder Abtriebswellen wirkenden Radialkräfte innerhalb der zulässigen Katalogwerte liegen. Wenn sie höher sind, das Getriebe größer dimensionieren bzw. die Abstützung der Last verändern. Wir erinnern daran, daß alle im Katalog angegebenen Werte sich auf Kräfte beziehen, die auf die Mitte des Wellenendes wirken. Diese Tatsache muß bei der Prüfung unbedingt berücksichtigt werden und nötigenfalls muß mit Hilfe der geeigneten Formeln die zulässige Kraft beim gewünschten Abstand  $x_{1,2}$  bestimmt werden. Siehe hierzu die Erläuterungen zu den Radialkräften in diesem Katalog.

c) Charges radiales

*Vérifier que les charges radiales agissant sur les arbres d'entrée et/ou de sortie se situent dans les valeurs de catalogue admises. Si elles sont supérieures, choisir la taille du réducteur supérieure ou modifier la reprise de charge. Rappelons que toutes les valeurs indiquées dans le catalogue se réfèrent à des charges agissant au milieu de la longueur disponible de l'arbre contrôlé.*  
*Par conséquent, en phase de vérification, il est indispensable de prendre en considération cette condition en déterminant, si nécessaire, avec les formules appropriées, la charge admissible à la distance  $x_{1,2}$  désirée. Se rapporter à ce propos aux paragraphes relatifs aux charges radiales.*



- |   |  |  |  |
|---|--|--|--|
| <p>d) Carichi assiali</p> <p>Anche gli eventuali carichi assiali dovranno essere confrontati con i valori ammissibili.</p> <p>Se si è in presenza di carichi assiali molto elevati o combinati con carichi radiali, si consiglia di interpellare il ns. Servizio Tecnico.</p> | <p>d) Thrust loads</p> <p><i>Actual thrust load must be found within 20% of the equivalent overhung load capacity.</i></p> <p><i>Should an extremely high, or a combination of radial and axial load apply, consult Bonfiglioli Technical Service.</i></p> | <p>d) Axialkräfte</p> <p>Auch die eventuell vorhandenen Axialkräfte müssen mit den im Katalog angegebenen zulässigen Werten verglichen werden. Wenn sehr hohe Axialkräfte wirken oder Axialkräfte in Kombination mit Radialkräften, bitte unseren Technischen Kundendienst zu Rate ziehen.</p> | <p>d) Charges axiales</p> <p><i>Les éventuelles charges axiales devront être comparées avec les valeurs admissibles. Si l'on est en présence de charges axiales très élevées ou combinées avec des charges radiales, nous conseillons d'interpeller notre Service Technique.</i></p> |
|---|--|--|--|

- |   |  |  |   |
|---|--|--|---|
| <p>e) Avviamenti orari</p> <p>Per servizi diversi da S1, con un numero rilevante di inserzioni/ora si dovrà tener conto di un fattore Z (determinabile con le indicazioni riportate nel capitolo dei motori) il quale definisce il numero max. di avviamenti specifico per l'applicazione in oggetto.</p> | <p>e) Starts per hour</p> <p><i>For duties featuring a high number of switches the actual starting capability in loaded condition [Z] must be calculated.</i></p> <p><i>Actual number of starts per hour must be lower than value so calculated.</i></p> | <p>e) Schaltungen/Stunde</p> <p>Bei anderen Betriebsarten als S1 mit einem hohen Wert für die Schaltungen/Stunde muß der Faktor Z berücksichtigt werden (er kann mit Hilfe der Angaben im Kapitel Motoren bestimmt werden), der die max. zulässige Anzahl von Schalten für eine bestimmte Anwendung definiert.</p> | <p>e) Démarrages/heure</p> <p><i>Pour les services différents de S1, avec un nombre important d'insertions/heure, il faudra prendre en considération un facteur Z (déterminé à l'aide des informations reportées dans le chapitre des moteurs) qui définit le nombre maximum de démarrages spécifique pour l'application concernée.</i></p> |
|---|--|--|---|

### 13 - INSTALLAZIONE

### 13 - INSTALLATION

### 13 - INSTALLATION

### 13 - INSTALLATION

È molto importante, per l'installazione del riduttore, attenersi alle seguenti norme:

*The following installation instructions must be observed:*

Für die Installation des Getriebes ist es äußerst wichtig, daß folgende Normen beachtet werden:

*Il est très important, pour l'installation du réducteur, de se conformer aux règles suivantes:*

- |   |   |  |  |
|---|---|--|--|
| <p>a) Assicurarsi che il fissaggio del riduttore, sia stabile onde evitare qualsiasi vibrazione. Installare (se si prevedono urti, sovraccarichi prolungati o possibili bloccaggi) giunti idraulici, frizioni, limitatori di coppia, ecc.</p>   | <p>a) <i>Make sure that the gearbox is correctly secured to avoid vibrations.</i></p> <p><i>If shocks or overloads are expected, install hydraulic couplings, clutches, torque limiters, etc.</i></p>   | <p>a) Sicherstellen, daß die Befestigung des Getriebes stabil ist, damit keine Schwingungen entstehen. Wenn es voraussichtlich zu Stößen, längerdauernden Überlasten oder zu Blockierungen kommen kann, sind entsprechende Schutzelemente wie hydraulische Kupplungen, Kupplungen, Rutschkupplungen usw. zu installieren.</p>  | <p>a) <i>S'assurer que la fixation du réducteur soit stable afin d'éviter toute vibration. Installer (en cas de chocs, de surcharges prolongées ou de blocages) des couples hydrauliques, des embrayages, des limiteurs de couple etc...</i></p>   |
| <p>b) Durante la verniciatura si dovranno proteggere i piani lavorati e il bordo esterno degli anelli di tenuta per evitare che la vernice ne essichi la gomma, pregiudicando la tenuta del paraolio stesso.</p>  | <p>b) <i>Before being paint coated, the machined surfaces and the outer face of the oil seals must be protected to prevent paint drying out the rubber and jeopardising the sealing function.</i></p>   | <p>b) Beim Lackieren die bearbeiteten Flächen und die Dichtringe schützen, damit der Anstrichstoff nicht dem Kunststoff angreift und somit die Dichtigkeit der Ölabdichtungen in Frage gestellt wird.</p>  | <p>b) <i>En phase de peinture, il faudra protéger les plans usinés et le bord extérieur des bagues d'étanchéité pour éviter que la peinture ne dessèche le caoutchouc, ce qui risque de nuire à l'efficacité du joint.</i></p>   |
| <p>c) Gli organi che vanno calettati sugli alberi di uscita del riduttore devono essere lavorati con tolleranza ISO H7 per evitare accoppiamenti troppo bloccati che, in fase di montaggio potrebbero danneggiare irreparabilmente il riduttore stesso. Inoltre, per il montaggio e lo smontaggio di tali organi si consiglia l'uso di adeguati tiranti ed estrattori utilizzando il foro filettato posto in testa alle estremità degli alberi.</p> | <p>c) <i>Parts fitted on the gearbox output shaft must be machined to ISO H7 tolerance to prevent interference fits that could damage the gearbox itself. Further, to mount or remove such parts, use suitable pullers or extraction devices using the tapped hole located at the top of the shaft extension.</i></p> | <p>c) Die Organe, die mit einer Keilverbindung auf der Abtriebswelle des Getriebes befestigt werden, müssen mit einer Toleranz ISO H7 gearbeitet sein, um allzu fest blockierte Verbindungen zu vermeiden, die eventuell zu einer irreparablen Beschädigung des Getriebes während des Einbaus führen könnten. Außerdem sind beim Ein- und Ausbau dieser Organe geeignete Zugstangen und Abzieher zu verwenden, wobei die Gewindebohrung an den Köpfen der Wellen zu verwenden ist.</p> | <p>c) <i>Les organes qui sont calés sur les arbres de sortie du réducteur doivent être réalisés avec une tolérance ISO H7 pour éviter les accouplements trop serrés qui, en phase de montage, pourraient endommager irrémédiablement le réducteur. En outre, pour le montage et le démontage de ces organes, nous conseillons d'utiliser un outillage et des extracteurs appropriés en utilisant le trou taraudé situé en extrémité d'arbre.</i></p> |





- d) Le superfici di contatto dovranno essere pulite e trattate con adeguati protettivi prima del montaggio, onde evitare l'ossidazione e il conseguente bloccaggio delle parti.
- e) Prima della messa in servizio del riduttore accertarsi che la macchina che lo incorpora sia in regola con le disposizioni della Direttiva Macchine 89/392 e successivi aggiornamenti.
- f) Prima della messa in funzione della macchina, accertarsi che la posizione del livello del lubrificante sia conforme alla posizione di montaggio del riduttore e che la viscosità sia adeguata al tipo del carico (vedi tabella B3).
- g) Nel caso di installazione all'aperto prevedere adeguate protezioni e/o carterture allo scopo di evitare l'esposizione diretta agli agenti atmosferici e alla radiazione solare.
- d) *Mating surfaces must be cleaned and treated with suitable protective products before mounting to avoid oxidation and, as a result, seizure of parts.*
- e) *Prior to putting the gear unit into operation make sure that the equipment that incorporates the same complies with the current revision of the Machines Directive 89/392.*
- f) *Before starting up the machine, make sure that oil level conforms to the mounting position specified for the gear unit.*
- g) *For outdoor installation provide adequate guards in order to protect the drive from rainfalls as well as direct sun radiation.*
- d) Die Berührungsflächen müssen sauber sein und vor der Montage mit einem geeigneten Schutzmittel behandelt werden, um Oxidierung und die daraus folgende Blockierung der Teile zu verhindern.
- e) Bevor das Getriebe im Betrieb zu setzen, muß man sich vergewissern daß die das Getriebe einbauende Maschine gemäß den aktuellen Regelungen der Maschine Richtlinie 89/392 ist.
- f) Vor Inbetriebnahme der Maschine sicherstellen, daß die Anordnung der Füllstandschrabe der Einbaulage angemessen ist, und die Viskosität des Schmiermittels der Belastungsart entspricht (siehe Tabelle B3).
- g) Bei Inbetriebnahme in Frein, muß man geeigneten Schutzgeräte vorsehen, um das Antrieb gegen Regen und direkte Sonnenstrahlung zu schützen.
- d) *Les surfaces de contact devront être propres et traitées avec des produits de protections appropriés avant le montage afin d'éviter l'oxydation et par suite le blocage des pièces.*
- e) *Avant la mise en service du réducteur, vérifier que la machine où il est monté est conforme aux normes de la Directive Machines 89/392 et ses mises à jour.*
- f) *Avant la mise en marche de la machine, s'assurer que la position du niveau du lubrifiant soit conforme à la position de montage du réducteur et que la viscosité soit appropriée au type de charge (voir tableau B3).*
- g) *En cas d'installation en plein air, il est nécessaire d'appliquer des protections et/ou des caches appropriés de façon à éviter l'exposition directe aux agents atmosphériques et aux rayonnements solaires.*

#### 14 - STOCCAGGIO

Il corretto stoccaggio dei prodotti ricevuti richiede l'esecuzione delle seguenti attività:

- a) Escludere aree all'aperto, zone esposte alle intemperie o con eccessiva umidità.
- b) Interporre sempre tra il pavimento ed i prodotti, pianali lignei o di altra natura, atti ad impedire il diretto contatto col suolo.
- c) Per periodi di stoccaggio e soste prolungate le superfici interessate agli accoppiamenti quali flange, alberi e giunti devono essere protette con idoneo prodotto antiossidante (Mobilarma 248 o equivalente). In questo caso i riduttori dovranno essere posizionati con il tappo di sfiato nella posizione più alta e riempiti interamente d'olio. Prima della loro messa in servizio nei riduttori dovrà essere ripristinata la corretta quantità, e il tipo di lubrificante.

#### 14 - STORAGE

*Observe the following instructions to ensure correct storage of the products:*

- a) *Do not store outdoors, in areas exposed to weather or with excessive humidity.*
- b) *Always place boards, wood or other material between the products and the floor. The gearboxes should not have direct contact with the floor.*
- c) *In case of long-term storage all machined surfaces such as flanges, shafts and couplings must be coated with a suitable rust inhibiting product (Mobilarma 248 or equivalent). Furthermore gear units must be placed with the fill plug in the highest position and filled up with oil. Before putting the units into operation the appropriate quantity, and type, of oil must be restored.*

#### 14 - LAGERUNG

Die korrekte Lagerung der Antriebe erfordert folgende Vorkehrungen:

- a) Die Produkte nicht im Freien lagern und nicht in Räumen, die der Witterung ausgesetzt sind, oder eine hohe Feuchtigkeit aufweisen.
- b) Die Produkte nie direkt auf dem Boden, sondern auf Unterlagen aus Holz oder einem anderen Material lagern.
- c) Bei anhaltenden Lager- und Haltszeiten müssen die Oberflächen für die Verbindung, wie Flansche, Wellen oder Kupplungen mit einem geeigneten Oxidationsschutzmittel behandelt werden (Mobilarma 248 oder ein äquivalentes Mittel). Übrigens müssen die Getriebe mit nach oben gerichteter Entlüftungsschraube gelagert und mit Öl gefüllt werden. Die Getriebe müssen vor ihrer Verwendung mit der angegebenen Menge des vorgesehenen Schmiermittels gefüllt werden.

#### 14 - STOCKAGE

*Un correct stockage des produits reçus nécessite de respecter les règles suivantes:*

- a) *Exclure les zones à ciel ouvert, les zones exposées aux intempéries ou avec humidité excessive.*
- b) *Interposer dans tous les cas entre le plancher et les produits des planches de bois ou des supports d'autre nature empêchant le contact direct avec le sol.*
- c) *Pour un stockage de long durée il faut protéger les surfaces d'accouplement (brides, arbres, manchon d'accouplement) avec produit anti oxydant (Mobilarma 248 ou equivalent). Dans ce cas les réducteurs devront être placés avec bouchon reniflard vers le haut et complètement rempli d'huile. Avant de la mise en service du réducteur, la bon quantité d'huile devra être rétabli selon la quantité indiqué sur le catalogue.*



## 15 - CONDIZIONI DI FORNITURA

I riduttori vengono forniti come segue:

- a) già predisposti per essere installati nella posizione di montaggio come definito in fase di ordine;
- b) collaudati secondo specifiche interne;
- c) le superfici di accoppiamento non sono verniciate;
- d) provvisti di dadi e bulloni per montaggio motori per la versione IEC;
- e) dotati di protezioni in plastica sugli alberi;
- f) provvisti di golfare di sollevamento (dove previsto).

## 15 - CONDITIONS OF SUPPLY

*Gear units are supplied as follows:*

- a) *configured for installation in the mounting position specified when ordering;*
- b) *tested to manufacturer specifications;*
- c) *mating machined surfaces come unpainted;*
- d) *nuts and bolts for mounting motors are provided;*
- e) *shafts are protected during transportation by plastic caps;*
- f) *supplied with lifting lug (where applicable).*

## 15 - LIEFERBEDINGUNGEN

Die Getriebe werden in folgendem Zustand geliefert:

- a) schon bereit für die Montage in der bei Bestellung festgelegten Einbaulage;
- b) nach werksinternen Spezifikationen geprüft;
- c) die Verbindungsflächen sind nicht lackiert;
- d) ausgestattet mit Schrauben und Muttern für die Montage der Motoren (Version mit Adapter für IEC-Motoren);
- e) alle Getriebe werden mit Kunststoffschutz auf den Wellen geliefert;
- f) mit Transporterring zum Anheben (falls vorgesehen).

## 15 - CONDITIONS DE LIVRAISON

*Les réducteurs sont livrés comme suit:*

- a) *déjà prédisposés pour être installés dans la position de montage comme défini en phase de commande;*
- b) *testés selon les spécifications internes;*
- c) *les surfaces de liaison ne sont pas peintes;*
- d) *équipés d'écrous et de boulons pour le montage des moteurs normalisés pour la version CEI;*
- e) *embouts de protections en plastique sur les arbres;*
- f) *dotés d'un crochet de levage (quand cela est prévu).*

## 16 - SPECIFICHE DELLA VERNICE

Le specifiche della vernice applicata sui riduttori (dove previsto) potranno essere richieste alle filiali o ai distributori che hanno fornito i gruppi.

## 16 - PAINT SPECIFICATIONS

*Specifications for paint applied to gearboxes (where applicable) may be obtained from the branches or dealers that supplied the units.*

## 16 - ANGABEN ZU DEN ANSTRICHSTOFFE

Die Spezifikationen des Lackes, der auf den Getriebe (wo erforderlich) verwendet wurde, können bei den Filialen oder Verkaufsstellen, die die Gruppen geliefert haben, angefordert werden.

## 16 - SPECIFICATIONS DE LA PEINTURE

*Les spécification de la peinture appliquée sur les réducteurs pourront, le cas échéant, être demandées aux filiales ou aux distributeurs ayant fourni les groupes.*

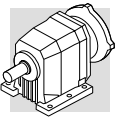

### 17 - CARATTERISTICHE COSTRUTTIVE

Le caratteristiche costruttive salienti sono:

- modularità
- compattezza
- montaggi universali
- rendimenti elevati
- basso livello di rumorosità
- ingranaggi in acciaio legato cementati e temprati
- casse in alluminio non verniciate nelle grandezze 05, 11, 21, 31, casse in ghisa ad alta resistenza, verniciate, nelle altre grandezze
- alberi in entrata e uscita in acciaio ad alta resistenza.

### 17 - DESIGN FEATURES

The main design characteristics are:

- modularity
- space effective
- universal mounting
- high efficiency
- quiet operation
- gears in hardened and case-hardened steel
- bare aluminium housing for sizes 05, 11, 21 and 31. Larger frame sizes come in sturdy cast iron housings
- input and output shafts from high grade steel.

### 17 - KONSTRUKTIVE EIGENSCHAFTEN

Die wichtigsten konstruktiven Eigenschaften sind:

- Baueinheitensystem
- Kompaktheit
- universelle Montage
- hohe Wirkungsgrade
- niedriger Geräuschpegel
- einsatzgehärtete und gehärtete Zahnräder aus legiertem Stahl
- Nicht lackierten Aluminiumgehäuse bei den Größen 05, 11, 21 und 31; hochwiderstandsfähige und lackierte Gußgehäuse bei den anderen Größen
- Antriebs- und Abtriebswellen aus hochwiderstandsfähigem Stahl.

### 17 - CARACTERISTIQUES DE CONSTRUCTION

Les principales caractéristiques de construction sont:

- modularité
- compacité
- montages universels
- rendements élevés
- faible niveau de bruit
- engrenages en acier allié cimentés et trempés
- carters en aluminium non peints dans les tailles 05, 11, 21, 31, carters en fonte à haute résistance peints dans les autres tailles
- arbres d'entrée et de sortie en acier à haute résistance.

(B1)

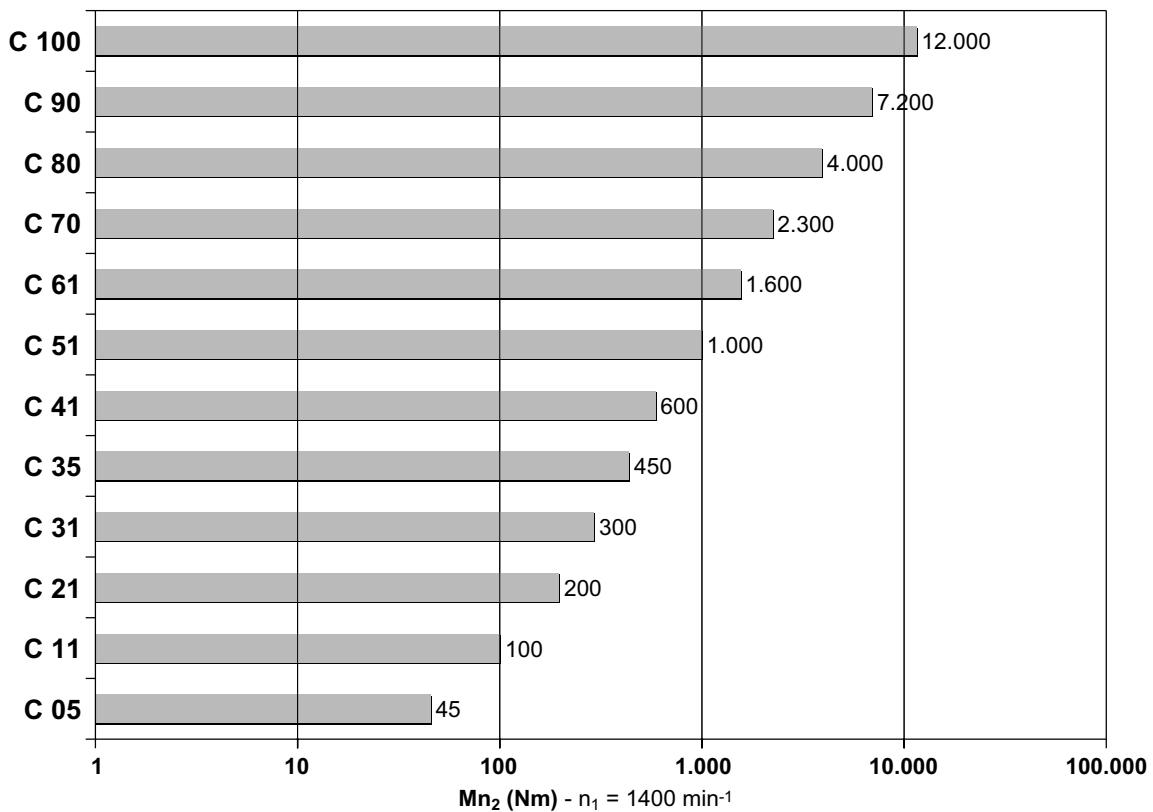

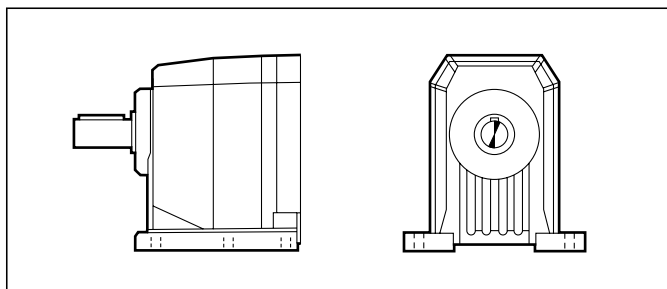
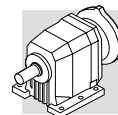
**P**

Piedi integrali  
*Foot mount*  
Mit integrierten Füßen  
*Carter à pattes monobloc*

C052...C100

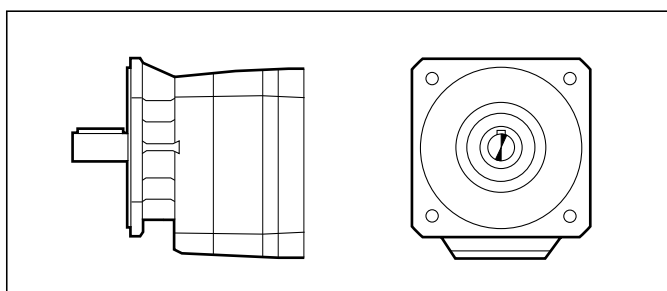
**F**

Flangia integrale  
*Flange mount*  
Mit integriertem Flansch  
*Carter à bride monobloc*

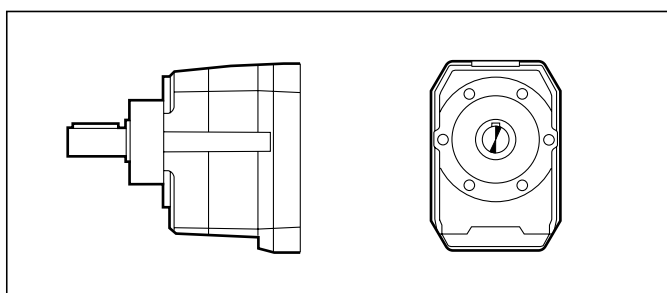
C052...C31  
C70...C100**U**

Cassa universale UNIBOX  
*UNIBOX - universal housing*  
Universalgehäuse UNIBOX  
*UNIBOX - carter universel*

C11...C61

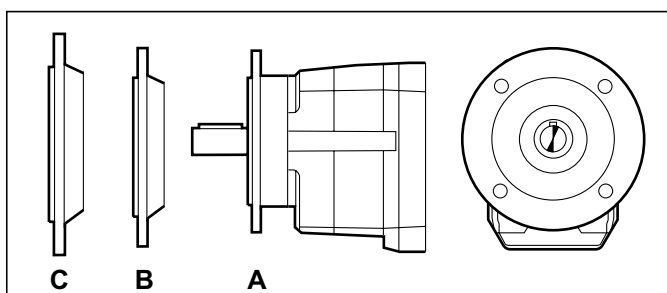
**UF**

UNIBOX flangia riportata  
*UNIBOX bolt-on flange*  
UNIBOX aufgesetztem Flansch  
*UNIBOX bride rapportée*

C11...C61

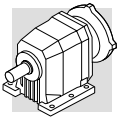

RIDUTTORE / GEAR UNIT  
GETRIEBE / REDUCTEUR

**C 31 2 F 52.4 S1 B5** .....

OPZIONI / OPTIONS  
OPTIONEN / OPTIONS



POSIZIONE DI MONTAGGIO / MOUNTING POSITION  
EINBAULAGEN / POSITION DE MONTAGE



C...P: **B3** (Standard), B6, B7, B8, V5, V6

C...F/U/UF: **B5** (Standard), B51, B53, B52, V1, V3

DESIGNAZIONE INGRESSO / INPUT CONFIGURATION  
BEZEICHNUNG DER ANTRIEBSSEITE / DESIGNATION ENTREE

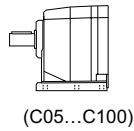

**S0**  
**S05**  
**S1**  
**S2**  
**S3**  
**S4**  
**S5**

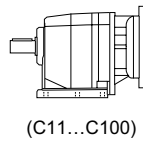
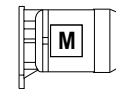

**P63**      **P160**  
**P71**      **P180**  
**P80**      **P200**  
**P90**      **P225**  
**P100**     **P250**  
**P112**     **P280**  
**P132**

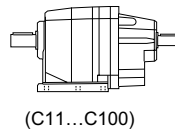
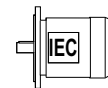

**HS**

RAPPORTO DI RIDUZIONE / GEAR RATIO  
ÜBERSETZUNG / RAPPORT DE REDUCTION

FORMA COSTRUTTIVA / VERSION / BAUFORM / FORME DE CONSTRUCTION

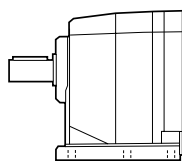

**P**  
(C05...C100)

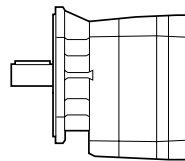

**F**  
(C05...C31)  
(C70...C100)

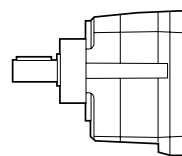

**U**  
(C11...C61)

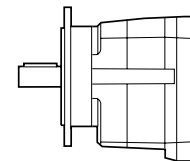

**UFA**  
**UFB**  
**UFC**  
(C11...C61)

STADI DI RIDUZIONE / REDUCTIONS  
GETRIEBESTUFEN / ETAGES DE REDUCTION

**2, 3, 4**









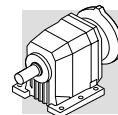







GRANDEZZA RIDUTTORE / GEAR FRAME SIZE / GETRIEBEBAUGRÖSSE / TAILLE REDUCTEUR

**05, 11, 21, 31, 35, 41, 51, 61, 70, 80, 90, 100**

TIPO RIDUTTORE: **C** = coassiale  
GETRIEBETYP: **C** = Stirnradgetriebe

GEARBOX TYPE: **C** = helical in-line  
TYPE DU REDUCTEUR: **C** = coaxial



Designazione motore	Motor designation	Motor bezeichnung	Designation moteur
	MOTORE / MOTOR MOTOR / MOTEUR	FRENO / BRAKE BREMSE / FREIN	
<b>M 1LA 4 230/400-50 IP54 CLF ..... W FD 7.5 R SB 220 SA .....</b>			
			OPZIONI OPTIONS OPTIONEN OPTIONS  22
		ALIMENTAZ. FRENO BRAKE SUPPLY BREMSVERSORGUNG ALIMENTATION FREIN  162  167  171	
		TIPO RADDRIZZATORE AC/DC RECTIFIER TYPE GLEICHRICHTERTYP TYPE ALIMENTATEUR <b>NB, SB, NBR, SBR</b>  163	
		LEVA DI SBLOCCO FRENO BRAKE HAND RELEASE BRESENTHANDLÜFTUNG LEVIER DE DEBLOCAGE FREIN <b>R, RM</b>  174	
		COPPIA FRENANTE / BRAKE TORQUE BREMSMOMENT/ COUPLE FREIN  164  168  172	
		TIPO FRENO / BRAKE TYPE BRESENTYP / TYPE DE FREIN <b>FD</b> (freno c.c./ d.c. brake / G.S. Bremse / frein c.c.) <b>FA, BA</b> (freno c.a./ a.c. brake / W.S. Bremse / frein c.a.)  164  168  172	
		POSIZIONE MORSETTIERA / TERMINAL BOX POSITION KLEMMENKASTENLAGE / POSITION BOITE A BORNE <b>W</b> (default), <b>N, E, S</b>  25	
		FORMA COSTRUTTIVA / MOTOR MOUNTING BAUFORM / FORM DE CONSTRUCTION — (motore integrato / compact motor kompaktes Motor / moteur compact) <b>B5</b> (motore IEC / IEC - motor / IEC Motor / moteur CEI)	
		CLASSE ISOLAMENTO / INSULATION CLASS ISOLIERUNGSKLASSE / CLASSE ISOLATION <b>CL F</b> standard <b>CL H</b> option  155	
		GRADO DI PROTEZIONE / DEGREE OF PROTECTION SCHUTZART / DEGRE DE PROTECTION <b>IP55</b> standard (IP54 - motore autofrenante / brake motor / Bremssmotor / moteur frein)  149	
		TENSIONE - FREQUENZA / VOLTAGE - FREQUENCY SPANNUNG - FREQUENZ / TENSION - FREQUENCE  153	
		NUMERO DI POLI / POLE NUMBER / POLZAHL / N.bre POLES <b>2, 4, 6, 2/4, 2/6, 2/8, 2/12, 4/6, 4/8</b>	
		GRANDEZZA MOTORE / MOTOR SIZE / MOTOR-BAUGRÖSSE / TAILLE MOTEUR <b>0B - 5LA</b> (motore integrato / compact motor / kompaktes Motor / moteur compact) <b>63A - 280M</b> (motore IEC / IEC motor / IEC - motor / moteur CEI)	
		TIPO MOTORE/ MOTOR TYPE / MOTORTYP / TYPE MOTEUR <b>M</b> = trifase integrato / compact 3-phase / kompaktes Dreiphasen / 3 phasé compact <b>BN</b> = trifase IEC / IEC 3-phase / IEC Dreiphasen / 3 phasé CEI	

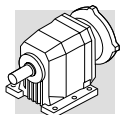

Opzioni riduttori	Gearbox options	Getriebe Optionen	Options réducteurs
<p><b>SO</b></p> <p>I riduttori C05, C11, C21, C31, C35, C41, solitamente forniti con lubrificante da BONFIGLIOLI RIDUTTORI, sono forniti privi di lubrificante.</p>	<p><b>SO</b></p> <p><i>Gear units C05, C11, C21, C31, C35, C41, usually factory filled with oil, to be supplied unlubricated.</i></p>	<p><b>SO</b></p> <p>Bei Lieferung ohne Schmierstoff (nur bei C05, C11, C21, C31, C35 und C41).</p>	<p><b>SO</b></p> <p><i>Les réducteurs C05, C11, C21, C31, C35, C41, habituellement fourni avec lubrifiant par la société BONFIGLIOLI RIDUTTORI, sont demandés sans lubrifiant.</i></p>
<p><b>LO</b></p> <p>I riduttori C51, C61, C70, C80, C90, C100 solitamente sprovvisti di lubrificante, sono richiesti con olio sintetico del tipo correntemente utilizzato da BONFIGLIOLI RIDUTTORI e riempiti in accordo alla posizione di montaggio richiesta.</p>	<p><b>LO</b></p> <p><i>Gearboxes C51, C61, C70, C80, C90, C100 usually supplied without oil, to be supplied with synthetic oil currently used by BONFIGLIOLI RIDUTTORI and filled according to the mounting position specified.</i></p>	<p><b>LO</b></p> <p>Für Getriebe C51, C61, C70, C80, C90, C100 die gewöhnlich ohne Schmiermittel geliefert werden, in Übereinstimmung mit der Einbaulage gefüllt mit dem normalerweise von BONFIGLIOLI RIDUTTORI verwendeten synthetischen Schmierstoff.</p>	<p><b>LO</b></p> <p><i>Les réducteurs C51, C61, C70, C80, C90, C100 habituellement dépourvus de lubrifiants, sont demandés avec huile synthétique du type couramment utilisé par BONFIGLIOLI RIDUTTORI et remplis conformément à la position de montage demandée.</i></p>
<p><b>DL</b></p> <p>L'albero lento è dotato di doppio anello di tenuta.</p>	<p><b>DL</b></p> <p><i>The output shaft features a dual oil seal.</i></p>	<p><b>DL</b></p> <p>Die Abtriebswelle ist mit Doppeldichtring geliefert.</p>	<p><b>DL</b></p> <p><i>L'arbre lent est équipé avec double joint d'étanchéité.</i></p>
<p><b>DV</b></p> <p>Due anelli di tenuta sull'albero veloce. (Disponibile solo sui motoriduttori compatti).</p>	<p><b>DV</b></p> <p><i>Dual oil seals on input shaft. (Only available for integral gearmotors).</i></p>	<p><b>DV</b></p> <p>2 Wellendichtringe auf der eintreibenden Welle. (Nur für Kompaktgetriebemotoren).</p>	<p><b>DV</b></p> <p><i>2 bagues d'étanchéité sur l'arbre rapide. (Disponibile seulement sur motoréducteurs compacts).</i></p>
<p><b>VV</b></p> <p>Anello di tenuta in Viton® sull'albero veloce.</p>	<p><b>VV</b></p> <p><i>Viton® oil seal on input shaft.</i></p>	<p><b>VV</b></p> <p>Wellendichtringe aus Viton® auf der eintreibenden Welle.</p>	<p><b>VV</b></p> <p><i>Bague d'étanchéité en Viton® sur l'arbre rapide.</i></p>
<p><b>PV</b></p> <p>Tutti gli anelli di tenuta in Viton®.</p>	<p><b>PV</b></p> <p><i>Both input and output shafts feature Viton® oil seals.</i></p>	<p><b>PV</b></p> <p>Alle Wellendichtringe aus Viton®.</p>	<p><b>PV</b></p> <p><i>Toutes les bagues d'étanchéité en Viton®.</i></p>

Opzioni motori	Motor options	Optionen Motoren	Options moteurs
<p><b>AA, AC, AD</b></p> <p>Posizione angolare leva di sblocco freno rispetto alla posizione morsettiera visto lato ventola. Posizione standard = 90° orari. AA = 0°, AC = 180°, AD = 90° antiorari.</p>	<p><b>AA, AC, AD</b></p> <p><i>Mutual position of the brake release lever and terminal box. View is from the fan side. Standard position = 90° clockwise. AA = 0°, AC = 180°, AD = 90° counterclockwise.</i></p>	<p><b>AA, AC, AD</b></p> <p>geben die Lage des Bremslüfterhebels zum Klemmenkasten an. Standard ist 90° im Uhrzeigersinn beim Ansehen der Lüfterradseite. AA = 0°, AC = 180°, AD = 90° entgegen dem Uhrzeigersinn.</p>	<p><b>AA, AC, AD</b></p> <p><i>Position angulaire du levier de déblocage du frein par rapport à la position de la boîte à borne en regardant du côté du ventilateur. Position standard = 90° sens horaire. AA = 0°, AC = 180°, AD = 90° sens anti-horaire.</i></p>
<p><b>AL, AR</b></p> <p>Antiretro (solo per motori di tipo M). Rotazione antioraria per motoriduttore a 2, 4 stadi di riduzione e oraria per motoriduttore a 3 stadi, guardando l'albero lento del motoriduttore.</p>	<p><b>AL, AR</b></p> <p><i>Anti run back (only for motors type M). CCW rotation for 2, 4 reduction stage gear motors and CW for 3 reduction stage motors viewing from gearbox output shaft.</i></p>	<p><b>AL, AR</b></p> <p>Rücklaufsperr (nur für Motoren des Typs M). Drehung entgegen dem Uhrzeigersinn für 2, 4 stufige Getriebemotoren und Drehung im Uhrzeigersinn für 3 stufige Getriebemotoren beim Anschauen der Getriebeabtriebswelle.</p>	<p><b>AL, AR</b></p> <p><i>Dispositif anti-retour (seulement pour moteurs de type M). Rotation anti-horaire pour motoréducteur à 2, 4 étages de réduction et horaire pour motoréducteur à 3 étages de réduction en regardant l'arbre lent du motoréducteur de face.</i></p>

(B2)

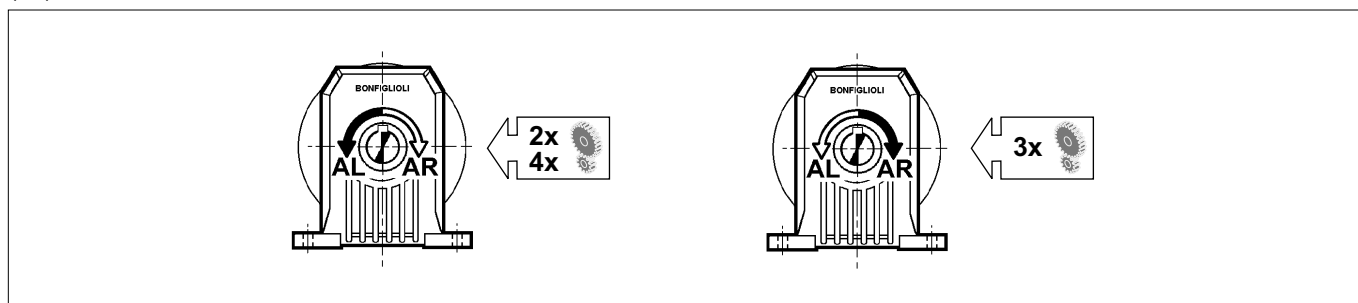

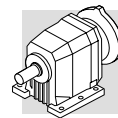

<b>CF</b> Filtro capacitivo.	<b>CF</b> <i>Capacitive filter.</i>	<b>CF</b> Kapazitive filter.	<b>CF</b> <i>Filtre capacitif.</i>
<b>D3</b> No. 3 sonde bimetalliche.	<b>D3</b> <i>3 nos bimetallic thermostats.</i>	<b>D3</b> 3 Bimetallfühler.	<b>D3</b> <i>3 sondes bimétalliques.</i>
<b>E3</b> No. 3 termistori per motori a singola polarità e doppia polarità (in accordo alla classe di isolamento).	<b>E3</b> <i>3 nos thermistors for single and double speed motors (according to the isolation class).</i>	<b>E3</b> 3 Kaltleiterthermistoren für ein-tourige Motoren und polumschaltbaren Motoren (gemäß der Isolierstoffklasse).	<b>E3</b> <i>3 thermistances pour moteurs à simple polarité ou double polarité (selon les classes d'isolation).</i>
<b>F1</b> Volano per avviamento progressivo.	<b>F1</b> <i>Flywheel for soft start and stop.</i>	<b>F1</b> Schwungrad zum sanften Anfahren.	<b>F1</b> <i>Volant pour démarrage progressif.</i>
<b>H1</b> Riscaldatori anticondensa. Alimentazione standard 230V±10%.	<b>H1</b> <i>Anti condensate heaters. Standard voltage 230V± 10%.</i>	<b>H1</b> Wicklungsheizung Standardspannung 230 V± 10%	<b>H1</b> <i>Réchauffeurs anticondensation. Alimentation standard 230V± 10%.</i>
<b>PN</b> Potenza a 60 Hz corrispondente alla potenza normalizzata a 50 Hz.	<b>PN</b> <i>60 Hz power corresponding to the normalized 50 Hz power.</i>	<b>PN</b> Die 60 Hz-Leistung wird an der 50 Hz-Normleistung ausgeglichen.	<b>PN</b> <i>Puissance à 60 Hz correspondante à la puissance normalisée à 50 Hz.</i>
<b>PS</b> Doppia estremità d'albero (esclude opzione RC e U1).	<b>PS</b> <i>Double shaft extention (barring RC and U1 options).</i>	<b>PS</b> Zweites Wellenende (schließt die Optionen RC und U1 aus).	<b>PS</b> <i>Double extrémité d'arbre (à l'exclusion de l'option RC et U1).</i>
<b>RC</b> Tettuccio parapiovra (esclude opzione PS).	<b>RC</b> <i>Drip cover (barring option PS).</i>	<b>RC</b> Schutzdach (schließt Option PS aus).	<b>RC</b> <i>Capot protection antipluie (option PS exclue).</i>
<b>RV</b> Bilanciamento rotore in grado di vibrazione R.	<b>RV</b> <i>Rotor balancing in vibration class R.</i>	<b>RV</b> Läufer in Vibrationsgrad R ausgewuchtet.	<b>RV</b> <i>Equilibrage rotor avec degré de vibration R.</i>
<b>TC</b> La variante del tettuccio tipo TC è da specificare quando il motore è installato in ambienti dell'industria tessile. L'opzione esclude le varianti EN1, EN2, EN3 e non è applicabile ai motori con freno tipo BA.	<b>TC</b> <i>Option TC is a rain canopy variant for textile industry environments. This option is not compatible with variants EN1, EN2, EN3 and will not fit motors equipped with a BA brake.</i>	<b>TC</b> Bei dieser Option handelt es sich um ein Schutzdach mit einem Textilnetz, dessen Einsatz empfohlen wird wenn der Motor in Bereichen der Textilindustrie installiert wird. Diese Option schließt die Möglichkeit der Optionen EN1, EN2, EN3 aus und kann bei Bremsmotoren vom Typ BN_BA nicht montiert werden.	<b>TC</b> <i>La variante du capot type TC est à spécifier lorsque le moteur est installé dans des sites de l'industrie textile. L'option exclue les variantes EN1, EN2, EN3 et n'est pas applicable aux moteurs avec frein type BA.</i>
<b>TP</b> Tropicalizzazione.	<b>TP</b> <i>Tropicalization.</i>	<b>TP</b> Tropfenfestigkeit.	<b>TP</b> <i>Tropicalisation.</i>
<b>U1</b> Servoventilazione (esclude opzioni PS e CUS).	<b>U1</b> <i>Forced cooling (barring options PS and CUS).</i>	<b>U1</b> Fremdbelüftung (Nicht anwendbare Gesamtheit an den Optionen PS und CUS).	<b>U1</b> <i>Servo-ventilateur (Pas applicable ensemble aux options PS et CUS).</i>
<b>U2</b> Servoventilatore privo di scatola morsettiera, dotato di cavi pre-cablati internamente. Esclude le opzioni PS e CUS.. Disponibile per motori: BN 71 ... BN 132, M1 ... M4.	<b>U2</b> <i>Separate supply forced ventilation without terminal box. Cables are pre-wired. Configuration is not compatible with options PS and CUS. Available on motors; BN 71 ... BN 132, M1 ... M4.</i>	<b>U2</b> Servoventilator ohne Klemmenkasten, bereits intern verkabelt. Nicht anwendbare Gesamtheit an den Optionen PS und CUS. Verfügbar für folgende Motoren: BN 71 ... BN 132, M1 ... M4.	<b>U2</b> <i>Servoventilateur sans boîte à bornes, doté de câbles pré-cablés à l'intérieur. Pas applicable ensemble aux options PS et CUS. Disponible pour moteurs: BN 71 ... BN 132, M1 ... M4.</i>



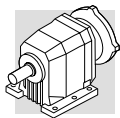

## 20 - LUBRIFICAZIONE

Gli organi interni dei riduttori Bonfiglioli sono lubrificati con un sistema misto di immersione e sbattimento dell'olio.

I gruppi C05, C11, C21, C31, C35 e C41 sono normalmente consegnati con carica di lubrificante dalla fabbrica, o dalla rete di vendita ufficiale.

Per questi stessi gruppi, nell'esecuzione predisposta per motorizzazione normalizzata IEC, un tappo di sfiato é fornito a corredo e dovrà essere installato ad esclusione della posizione di montaggio V5, prima della messa in esercizio del riduttore.

I gruppi di grandezza C51 e superiori sono normalmente forniti privi di lubrificante, e sarà cura dell'utilizzatore riempirli di olio prima della messa in servizio.

Le tavole che seguono sono da riferimento nell'interpretazione delle posizioni di montaggio, della collocazione dei tappi di servizio e delle quantità di lubrificante.

**Queste ultime sono indicative, e per il corretto riempimento si dovrà fare riferimento alla mezzeria del tappo, o dell'astina di livello, se presente.**

**Rispetto a questa condizione la quantità di lubrificante riportata in tabella può presentare scostamenti, occasionalmente anche rilevanti.**

Il lubrificante "long life" fornito di serie è di natura sintetica e, a meno di contaminazione dall'esterno, non richiede sostituzioni periodiche per tutto l'arco di vita del riduttore.

Lo stesso lubrificante consente inoltre funzionamenti a temperature ambiente  $0 < t_a < 50 \text{ }^\circ\text{C}$ .

Per funzionamento a temperature inferiori consultare il ns. Servizio Tecnico.

## 20 - LUBRICATION

*The inner parts of Bonfiglioli gear units are oil-bath and splash lubricated.*

*Frame sizes C05, C11, C21, C31, C35 and C41 are supplied by the factory, or by the authorized dealers, already filled with oil.*

*For same units configured with the IEC-normalized motor mounting flange a breather plug is also supplied. With the exception of the V5 mounting position, the breather must replace the closed plug supplied for transportation purposes, prior to putting the gear unit into operation.*

*Unless otherwise specified, units size C51 and larger are usually supplied unlubricated at it will be the customer care to fill them with oil prior to putting them into operation.*

*The charts here after must be referred to as for the mounting position pattern and the corresponding oil plugs, if applicable, and related lubricant quantity.*

*Values for the oil quantity are indicative with the proper filling always represented by the center of the sight glass, or the dipstick, when this is supplied.*

*In some cases, discrepancies, occasionally also substantial, versus the oil quantities listed in the chart may be noticed.*

*The "long life" polyglycol-based lubricant supplied by the factory, in the absence of contamination, does not require periodical oil changes throughout the lifetime of the gear unit.*

*Operation at an ambient temperature  $0 < t_a < 50 \text{ }^\circ\text{C}$  is allowed.*

*Should the gear unit operate at temperature below  $0 \text{ }^\circ\text{C}$ , please consult Bonfiglioli Technical Service Dept. for advise.*

## 20 - SCHMIERUNG

Die Schmierung der Getriebe von Bonfiglioli erfolgt durch eine Kombination aus Ölbad- und Tauchschmierung.

Die Getriebegrößen C05, C11, C21, C31, C35 und C41 sind ab Werk mit einer Lebensdauer-schmierung versehen.

Wenn diese Baugrößen mit einem IEC-Eingang ausgeliefert werden, dann gehört ein Lüfter zum Lieferumfang, außer bei der Einbaulage V5. Während des Transports wird anstatt des Lüfters ein Stopfen verwendet. Vor dem Einsatz des Getriebes muss dieser Stopfen durch den Lüfter ersetzt werden.

Die Getriebe ab der Größe C51 werden ohne Öfüllung ausgeliefert. Vor der Inbetriebnahme muss deshalb auf das Einfüllen der richtigen Öfüllmenge geachtet werden!

Bitte beachten Sie dazu auch die nachfolgenden Kapitel über die Positionen der Stopfen und Ölschaugläser und den entsprechenden Öfüllmengen.

**Die im Katalog angegeben Öl-füllmengen sind Anhaltswerte! Maßgebend ist, das der Ölstand bis Mitte des Ölschauglas für die entsprechende Einbaulage aufgefüllt wird.**

**Auf Abweichungen gegenüber den in der Tabelle angegebenen Ölmengen, gelegentlich nicht unwesentliche, wird hingewiesen.**

Die mit Lebensdauerschmierung gelieferten Serien sind mit synthetischem Öl auf Polyglykolbasis gefüllt. Falls dieses Öl nicht verunreinigt wird, ist während der Lebensdauer des Getriebes kein Ölwechsel nötig.

Die zulässige Umgebungstemperatur für den Betriebe liegt im Bereich von  $0 < t_a < 50 \text{ }^\circ\text{C}$ .

Falls ein Antrieb bei Temperaturen unterhalb von  $0^\circ$  betrieben werden soll, kontaktieren sie bitte unseren technischen Service für weitere Anweisungen.

## 20 - LUBRIFICATION

*Les organes internes des réducteurs Bonfiglioli sont lubrifiés avec un système mixte d'immersion et de battement de l'huile.*

*Les groupes C05, C11, C21, C31, C35 et C41 sont normalement livré avec charge de lubrifiant de l'usine, ou du réseau de vente officielle.*

*Pour ces mêmes groupes, dans l'exécution prévue pour motorisation normalisée IEC, un bouchon de reniflard est fourni et devra être installé, sauf position de montage V5, avant la mise en service du réducteur.*

*Les groupes de grandeur C51 et supérieur sont normalement fournis sans lubrifiant, et sera par l'utilisateur le remplissage d'huile avant la mise en service.*

*Les tables suivantes sont de référence dans l'interprétation des positions de montage, du placement des bouchons de service et de la quantité de lubrifiant.*

**Ces dernières sont indicatives, et pour le correct remplissage il faut faire référence au bouchon de niveau ou à la jauge à huile, si présent.**

**Par rapport à cette condition la quantité de lubrifiant indiqué dans le tableau peut présenter des écarts, occasionnellement considérables.**

*Le lubrifiant "long life" ; fourni de série est de nature synthétique et, à moins de contamination par l'extérieur, il ne demande pas des remplacements périodiques pour tout l'arc de vie du réducteur.*

*Le même lubrifiant permet fonctionnements à des températures ambiente  $0 < t_a < 50 \text{ }^\circ\text{C}$ .*

*Pour fonctionnement à des températures inférieures consulter notre Service Technique.*

(B3)

Tipo di carico / Type of duty Art der Belastung / Type de charge	$t_a$ $0 \text{ }^\circ\text{C} - 20 \text{ }^\circ\text{C}$		$t_a$ $20 \text{ }^\circ\text{C} - 40 \text{ }^\circ\text{C}$	
	Olio minerale Mineral oil Mineralöl Huile minérale ISO VG	Olio sintetico Synthetic oil Syntheseöl Huile synthétique ISO VG	Olio minerale Mineral oil Mineralöl Huile minérale ISO VG	Olio sintetico Synthetic oil Syntheseöl Huile synthétique ISO VG
Carico leggero / Light duty / Leicht / Charge légère	150	150	220	220
Carico medio / Medium duty / Normal / Charge moyenne	150	150	320	220
Carico pesante / Heavy duty / Schwer / Charge lourde	200	200	460	320

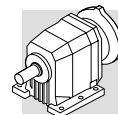



Quantità di lubrificante [ l ]

Oil quantity [ l ]

Schmiermittelmenge [ l ]

Quantité de lubrifiant [ l ]

	 [l]																	
	P						F						U - UF					
	B3	B6	B7	B8	V5	V6	B5	B51	B53	B52	V1	V3	B5	B51	B53	B52	V1	V3
C 05 2	0.35	0.35	0.35	0.35	0.35	0.35	0.35	0.35	0.35	0.35	0.35	0.35	-	-	-	-	-	-
C 11 2	0.45	0.45	0.45	0.45	0.50	0.60	0.40	0.40	0.50	0.50	0.50	0.60	0.40	0.40	0.50	0.50	0.50	0.60
C 21 2	0.80	0.80	0.80	0.80	0.85	1.1	0.75	0.75	0.75	0.75	0.80	1.00	0.75	0.75	0.75	0.75	0.80	1.00
C 21 3	1.2	1.2	1.2	1.2	1.3	1.4	1.2	1.2	1.2	1.2	1.3	1.4	1.2	1.2	1.2	1.2	1.3	1.4
C 31 2	1.4	1.4	1.4	1.4	1.5	1.5	1.3	1.3	1.3	1.3	1.5	1.5	1.3	1.3	1.3	1.3	1.5	1.5
C 31 3	1.6	1.6	1.6	1.6	1.8	1.8	1.6	1.6	1.6	1.6	1.8	1.8	1.6	1.6	1.6	1.6	1.8	1.8
C 35 2	1.6	1.5	1.5	1.3	2.1	2.4	-	-	-	-	-	-	1.6	1.5	1.5	1.3	2.1	2.4
C 35 3	1.5	1.4	1.5	1.3	2.0	2.3	-	-	-	-	-	-	1.5	1.4	1.5	1.3	2.0	2.3
C 35 4	2.3	2.1	2.3	2.1	2.7	3.1	-	-	-	-	-	-	2.3	2.1	2.3	2.1	2.7	3.1
C 41 2	2.2	2.0	2.1	1.9	2.7	3.4	-	-	-	-	-	-	2.2	2.0	2.1	1.9	2.7	3.4
C 41 3	2.1	1.9	2.1	1.9	2.6	3.2	-	-	-	-	-	-	2.1	1.9	2.1	1.9	2.6	3.2
C 41 4	2.8	2.6	2.8	2.6	3.5	3.9	-	-	-	-	-	-	2.8	2.6	2.8	2.6	3.5	3.9
C 51 2	3.1	3.0	3.1	3.0	4.3	5.0	-	-	-	-	-	-	3.1	3.0	3.1	3.0	4.3	5.0
C 51 3	3.0	2.8	3.1	3.0	4.1	4.9	-	-	-	-	-	-	3.0	2.8	3.1	3.0	4.1	4.9
C 51 4	4.3	4.1	4.4	4.2	5.4	6.1	-	-	-	-	-	-	4.3	4.1	4.4	4.2	5.4	6.1
C 61 2	4.2	4.0	4.2	4.1	6.0	6.7	-	-	-	-	-	-	4.2	4.0	4.2	4.1	6.0	6.7
C 61 3	4.2	4.0	4.2	4.1	6.0	6.7	-	-	-	-	-	-	4.2	4.0	4.2	4.1	6.0	6.7
C 61 4	6.1	5.9	6.1	6.0	7.9	8.6	-	-	-	-	-	-	6.1	5.9	6.1	6.0	7.9	8.6
C 70 2	6.5	8.5	8.5	7.5	11	7.5	6.5	8.5	8.5	7.5	11	7.5	-	-	-	-	-	-
C 70 3	6.5	8.5	8.5	7.5	11	7.5	6.5	8.5	8.5	7.5	11	7.5	-	-	-	-	-	-
C 70 4	6.5	8.5	8.5	7.5	11	8	6.5	8.5	8.5	7.5	11	7.5	-	-	-	-	-	-
C 80 2	11	14	14	13	18	13	11	14	14	13	18	13	-	-	-	-	-	-
C 80 3	11	14	14	13	18	13	11	14	14	13	18	13	-	-	-	-	-	-
C 80 4	11	14	14	13	18	13	11	14	14	13	18	13	-	-	-	-	-	-
C 90 2	19	25	25	22	31	22	19	25	25	22	31	22	-	-	-	-	-	-
C 90 3	19	25	25	22	31	22	19	25	25	22	31	22	-	-	-	-	-	-
C 90 4	19	25	25	22	31	22	19	25	25	22	31	22	-	-	-	-	-	-
C 100 2	27	37	37	33	45	33	27	37	37	33	45	33	-	-	-	-	-	-
C 100 3	27	37	37	33	45	33	27	37	37	33	45	33	-	-	-	-	-	-
C 100 4	27	37	37	33	45	33	27	37	37	33	45	33	-	-	-	-	-	-

 Lubrificazione permanente

 Life lubricated

 Dauerschmierung

 Lubrification permanente

 SHELL Tivela OIL S 320 (for life)

## 21- POSIZIONI DI MONTAGGIO E ORIENTAMENTO MORSETTIERA

Gli orientamenti delle morsettiere dei motori sono identificati osservando il motore dal lato ventola; l'orientamento standard è evidenziato in nero (W).

**Posizione angolare leva di sblocco freno.**  
Nei motori autofrenanti, la leva di sblocco freno (se richiesta) ha l'orientamento standard a 90° rispetto alla morsettiere (posizione AB); specificare con relative opzioni qualora l'orientamento desiderato sia diverso.

## 21 - MOUNTING POSITION AND TERMINAL BOX ORIENTATION

Location of motor terminal box can be specified by viewing the motor from the fan side; standard location is shown in black (W).

**Angular position of the brake release lever.**  
Unless otherwise specified, brake motors have the manual device side located, 90° apart from terminal box. Different angles can be specified through the relevant options available.

## 21 - EINBAULAGEN UND LAGE DES KLEMMENKASTENS

Die Angaben zur Lage des Klemmenkastens beziehen sich auf das von der Lüfterseite her betrachtete Getriebe. Die Standardorientierung ist schwarz hervorgehoben (W).

**Winkellage des Handlüfterhebels.**  
Bei Bremsmotoren wird der Handlüfterhebel (auf Anfrage) standardmäßig auf 90° gegenüber des Klemmkastens (AB-Anordnung) geliefert; wird eine andere Anordnung verlangt, muß dies bei der Bestellung durch das geeignete Option angegeben werden.

## 21 - POSITIONS DE MONTAGE ET ORIENTATION BOITE A BORNE

Les orientations des boîtes à bornes des moteurs sont définies en regardant le moteur du côté ventilateur. L'orientation standard est indiquée en noir (W).

**Position angulaire levier déblocage frein.**  
Dans les moteurs freins, ce levier (si requis) aura l'orientation standard de 90° par rapport à la boîte à bornes (position AB); spécifier avec options relatives si l'orientation désirée est différente.

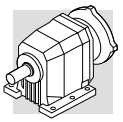

# C 11...C41

Legenda:		Key:	Zeichenerklärung:	Légende:	
		Tappo di sfiato / carico	Filling / breather plug	Einfüll / Ablasschraube	Bouchon de event / remplissage
		Tappo di livello	Level plug	Östandsschraube	Bouchon de niveau
		Tappo di scarico	Drain plug	Öablasschraube	Bouchon de vidange

## C\_P

(B5)

### B3

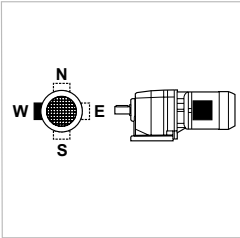
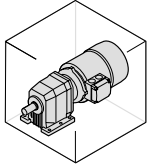

W = Default

### \_HS

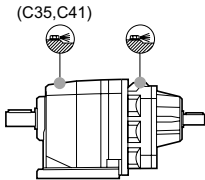
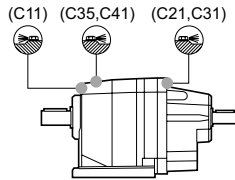

### \_P (IEC)

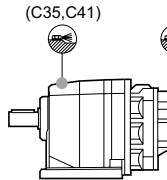
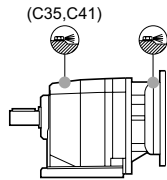

### \_S

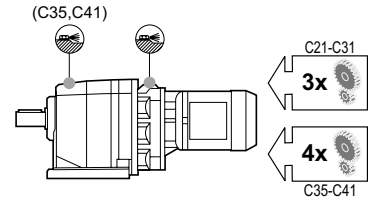
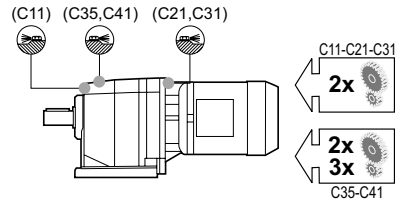

### B6

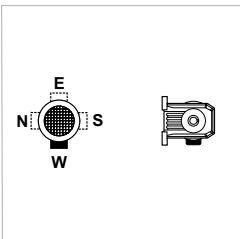
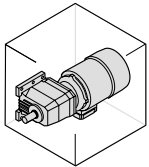

W = Default

(C35,C41)

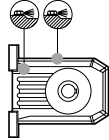

(C35,C41)

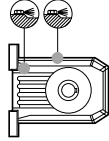

(C35,C41)

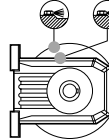

(C35,C41)

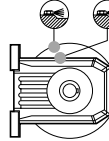

(C35,C41)

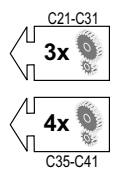
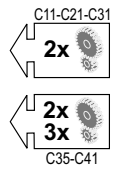
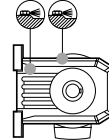

### B7

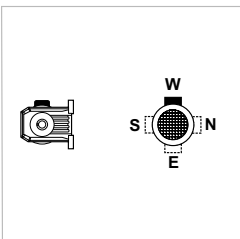
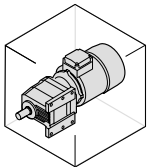

W = Default

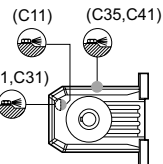

(C35,C41)

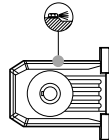

(C21,C31)

(C35,C41)

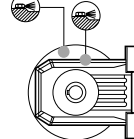

(C35,C41)

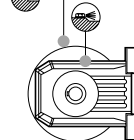

(C11) (C35,C41)

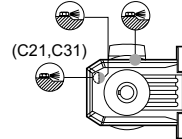

(C35,C41)

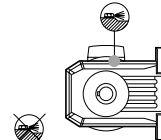

(C21,C31)

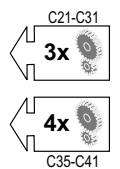
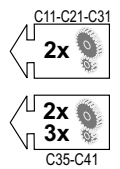

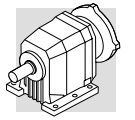

## C\_P

(B6)

**\_HS**

**\_P (IEC)**

**\_S**

**B8**

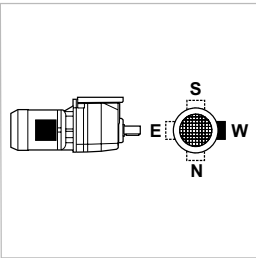
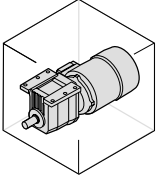

W = Default

(C21,C31) (C11,C35,C41)

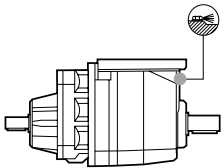
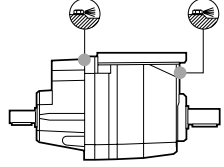

(C35,C41)

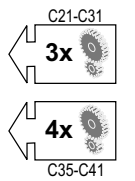
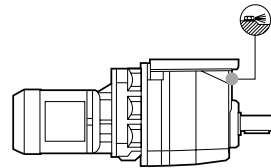
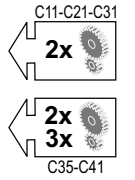
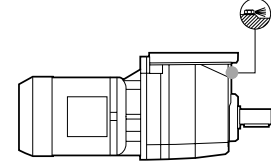
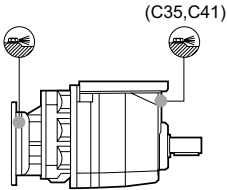
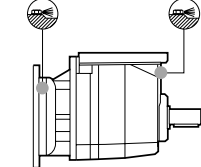

**V5**

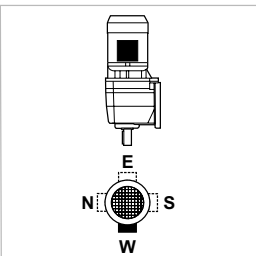
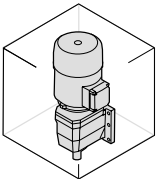

W = Default

(C21, C31, C35, C41)

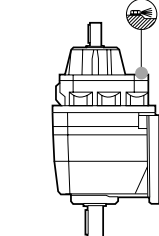
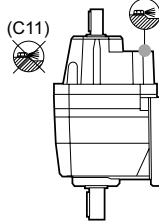

(C35, C41)

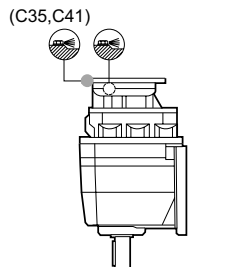
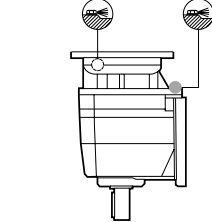

(C21, C31)

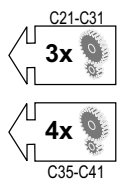
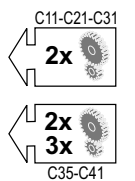
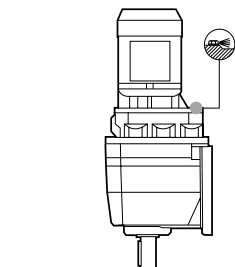
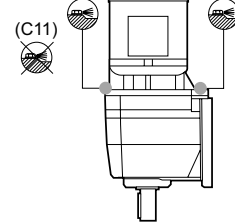

**V6**

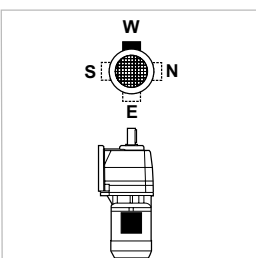
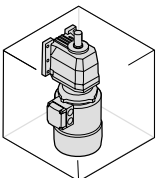

W = Default

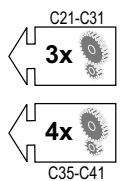
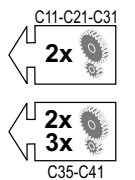
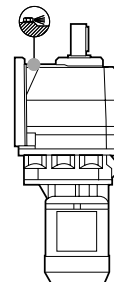
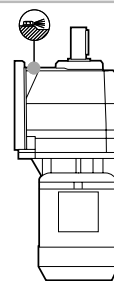
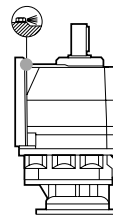
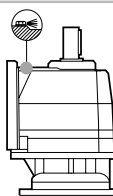
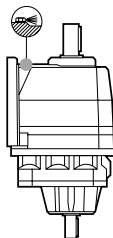
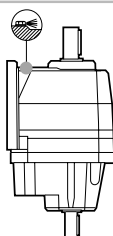

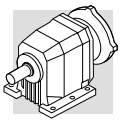

# C 11...C 41

C\_F

C\_U

C\_UF

(B7)

\_HS

\_P (IEC)

\_S

B5

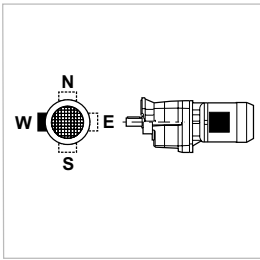
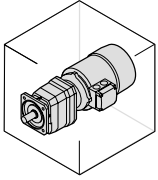

W = Default

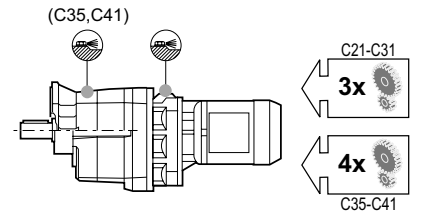
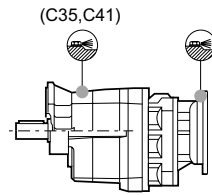
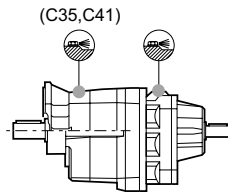
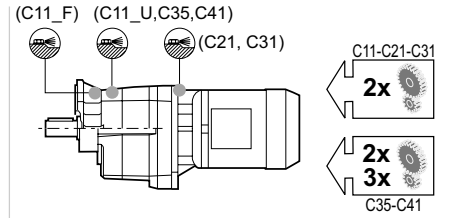
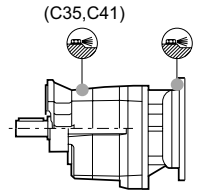
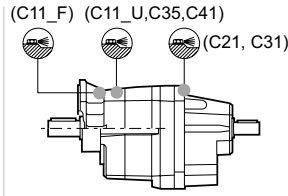

B51

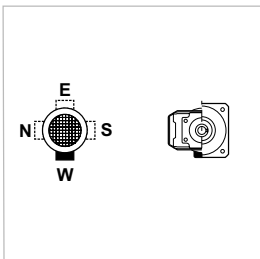
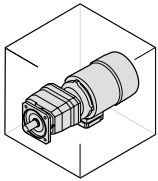

W = Default

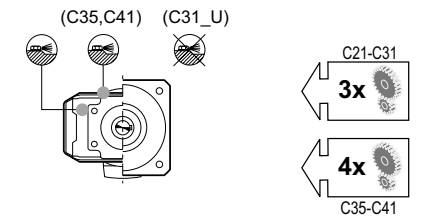
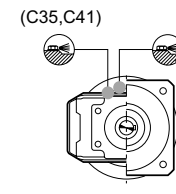
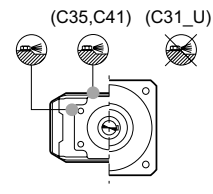
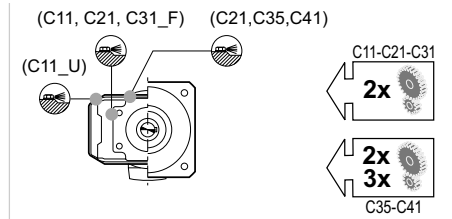
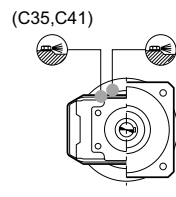
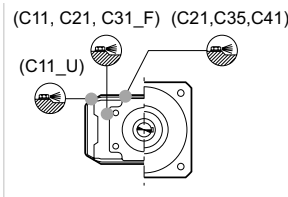

B53

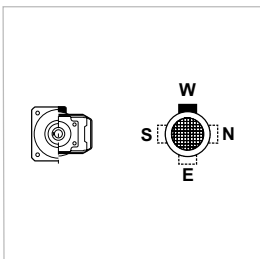
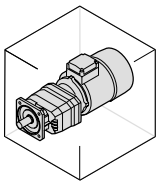

W = Default

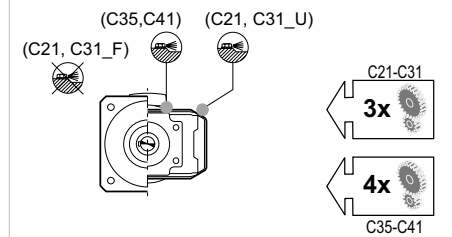
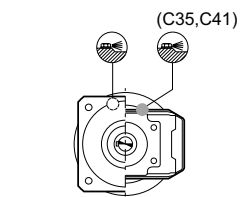
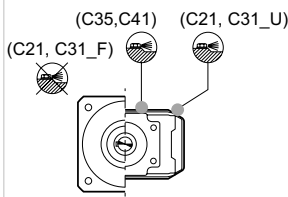
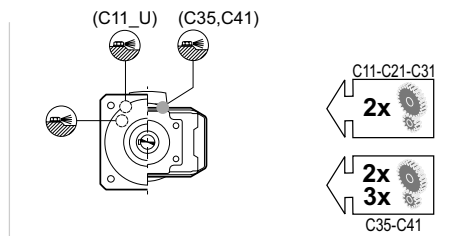
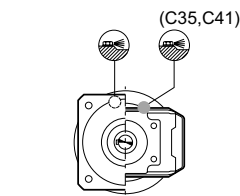
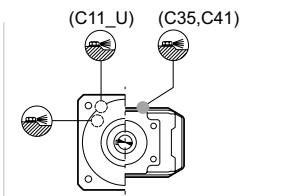

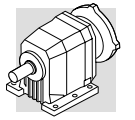

## C\_F

## C\_U

## C\_UF

(B8)

**\_HS**

**\_P (IEC)**

**\_S**

### B52

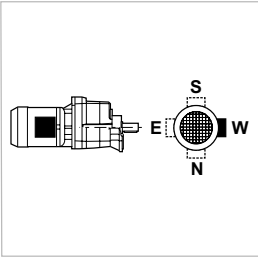
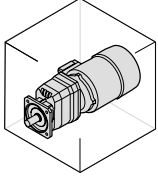

W = Default

(C21, C31) (C11\_U)  
(C11\_F, C35, C41)

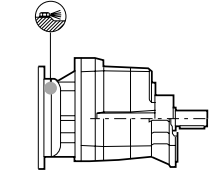
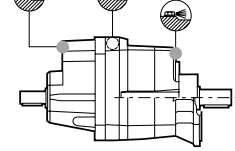

(C11\_U) (C11\_F)  
(C21, C31\_U) (C21, C31\_F, C35, C41)

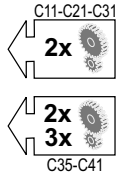
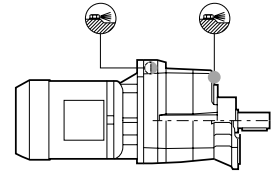

(C21, C31\_U) (C21, C31\_F)  
(C35, C41)

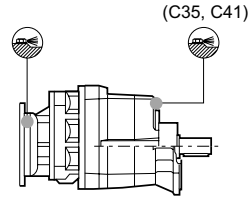
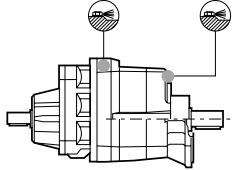

(C21, C31\_U) (C21, C31\_F)  
(C35, C41)

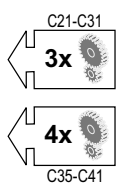
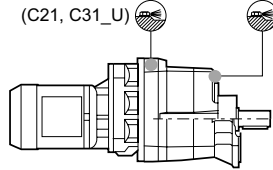

### V1

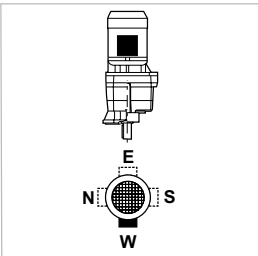
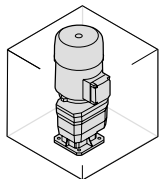

W = Default

(C21, C31, C35, C41)

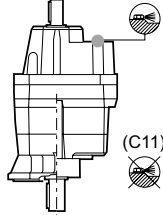

(C35, C41)

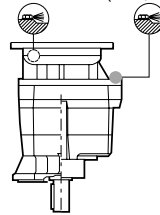

(C21, C31) (C35, C41)

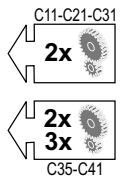
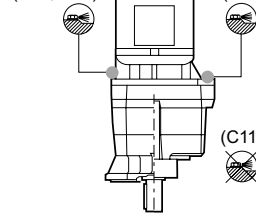

(C35, C41)

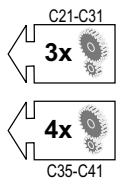
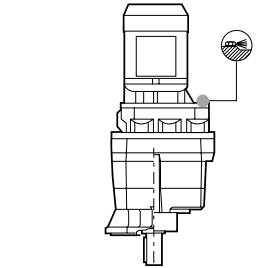
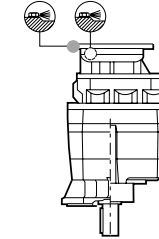

### V3

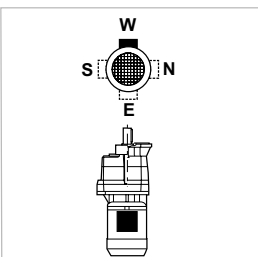
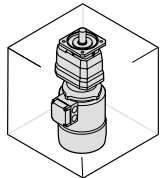

W = Default

(C11\_F) (C11\_U)  
(C21, C31\_F) (C21, C31\_U)  
(C35, C41)

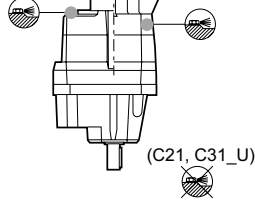

(C11\_F) (C11\_U)  
(C21, C31\_F) (C21, C31\_U)  
(C35, C41)

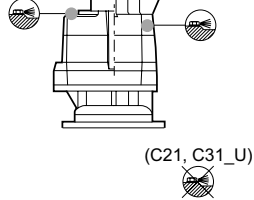

(C11\_F) (C11\_U)  
(C21, C31\_F) (C21, C31\_U)  
(C35, C41)

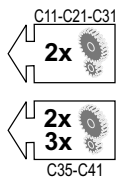
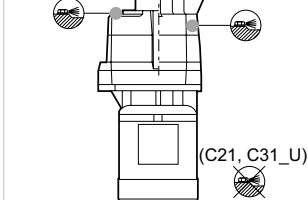

(C21, C31\_F) (C21, C31\_U)  
(C35, C41)

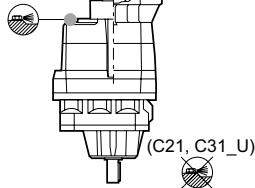

(C21, C31\_F) (C21, C31\_U)  
(C35, C41)

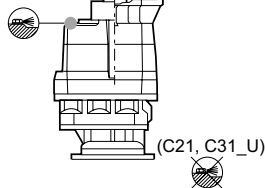

(C21, C31\_F) (C21, C31\_U)  
(C35, C41)

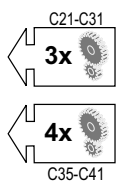
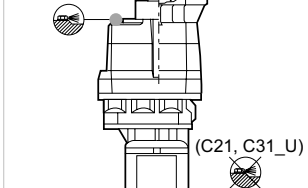

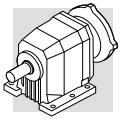

# C 51...C 61

## C\_P

(B9)

**\_HS**

**\_P (IEC)**

**\_S**

**B3**

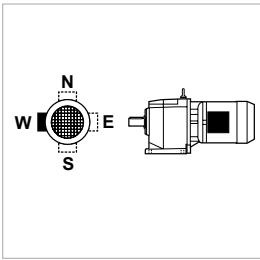
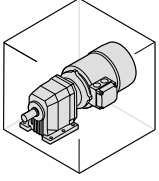

W = Default

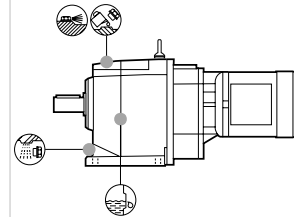
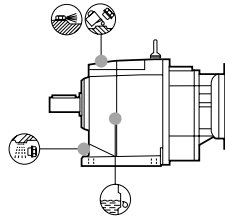
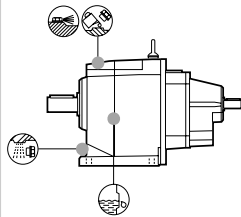
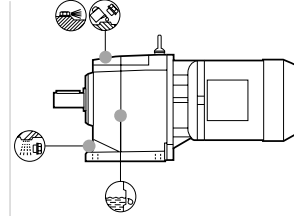
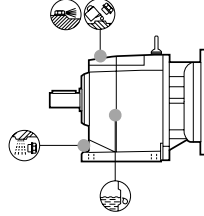
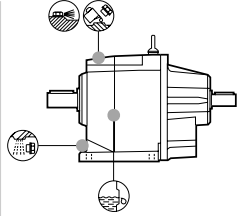

**B6**

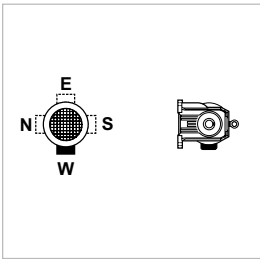
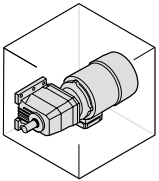

W = Default

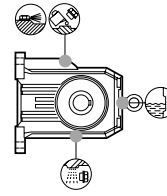
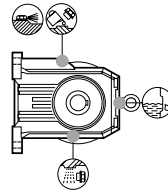
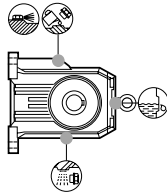
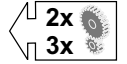
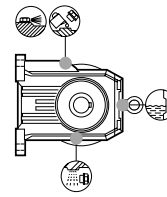
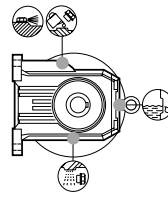
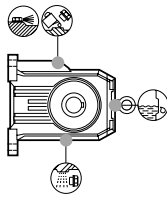

**B7**

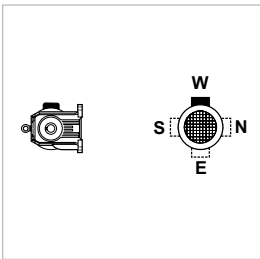
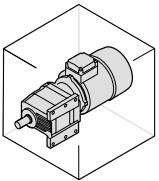

W = Default

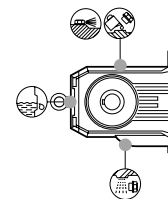
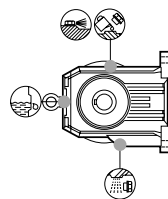
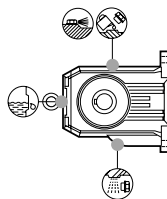
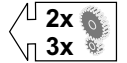
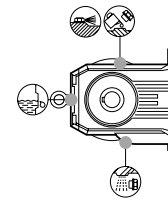
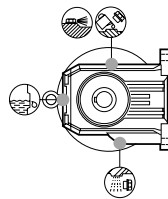
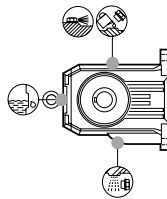

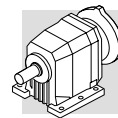

## C\_P

(B10)

**\_HS**

**\_P (IEC)**

**\_S**

**B8**

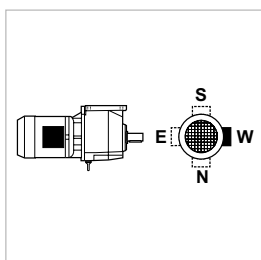
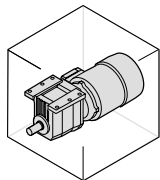

W = Default

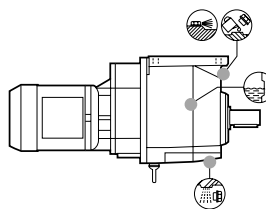
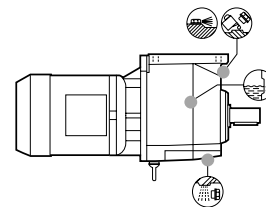
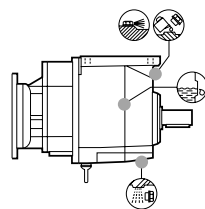
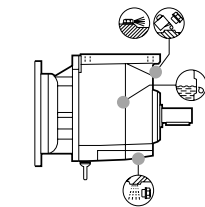
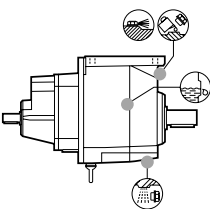
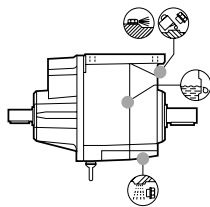

2x  
3x

4x

**V5**

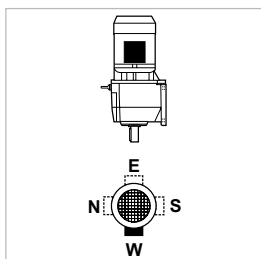
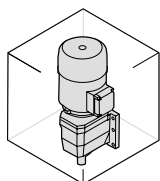

W = Default

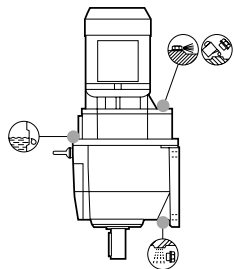
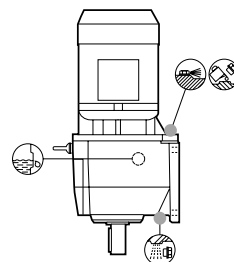
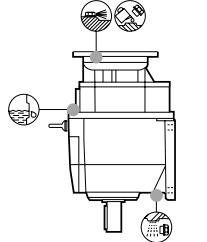
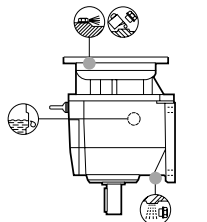
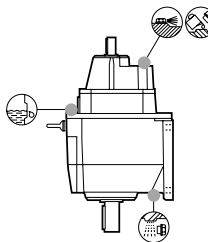
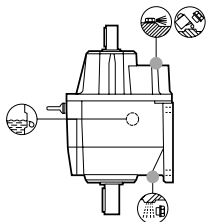

2x  
3x

4x

**V6**

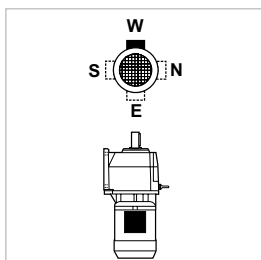
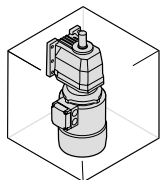

W = Default

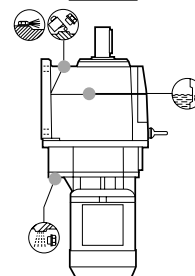
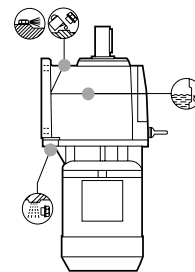
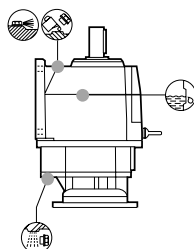
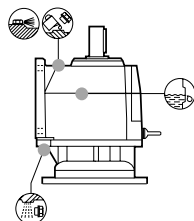
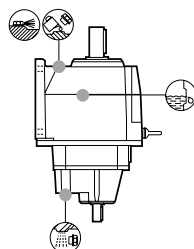
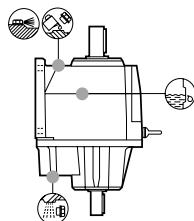

2x  
3x

4x



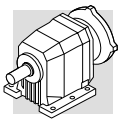

# C 51...C 61

C\_F

C\_U

C\_UF

(B11)

\_HS

\_P (IEC)

\_S

B5

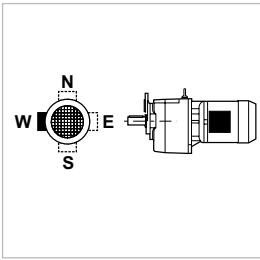
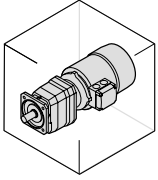

W = Default

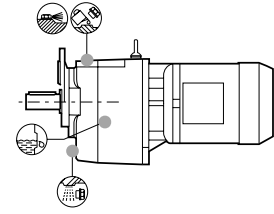
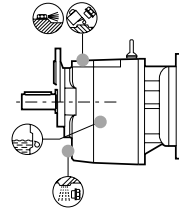
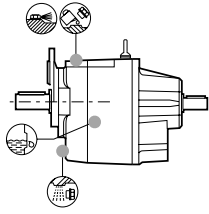

2x  
3x

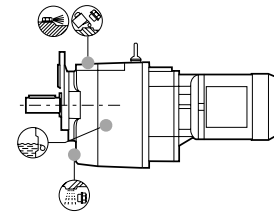
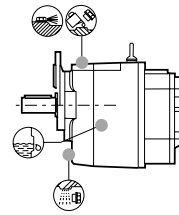
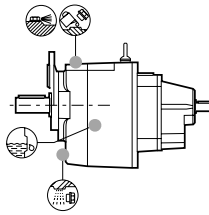

4x

B51

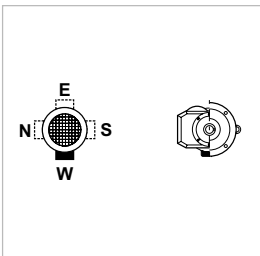
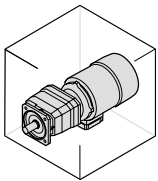

W = Default

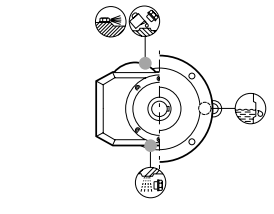
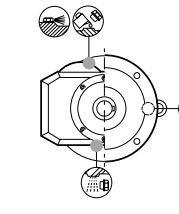
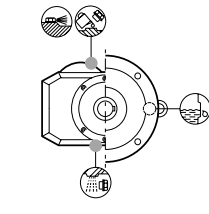

2x  
3x

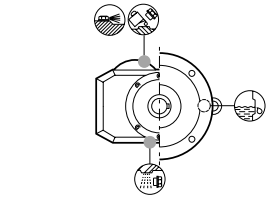
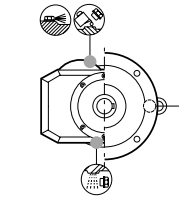
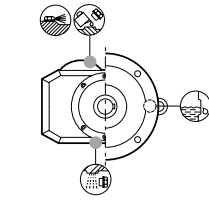

4x

B53

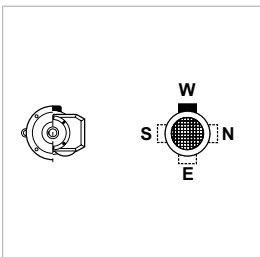
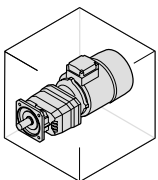

W = Default

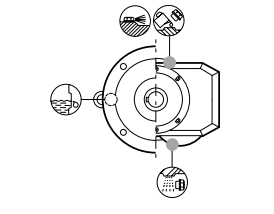
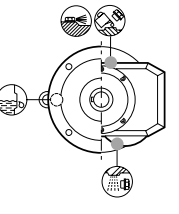
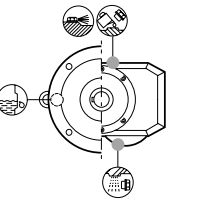

2x  
3x

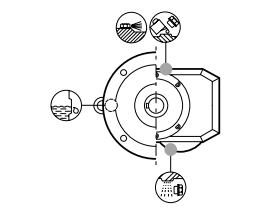
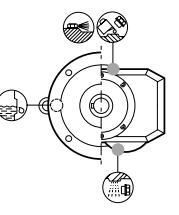
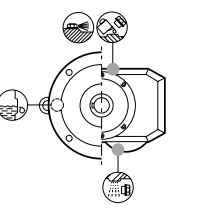

4x

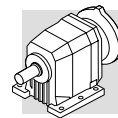

## C\_F

## C\_U

## C\_UF

(B12)

**\_HS**

**\_P (IEC)**

**\_S**

### B52

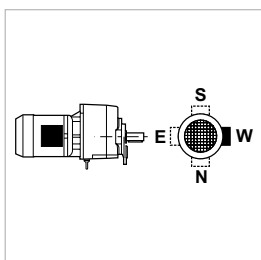
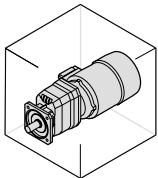

W = Default

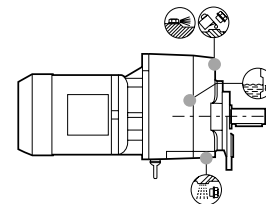
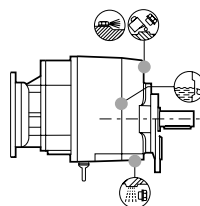
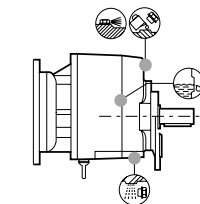
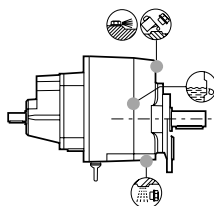
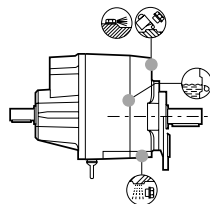

← 2x  
3x

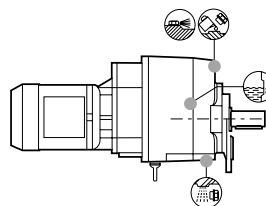

← 4x

### V1

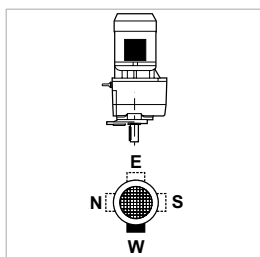
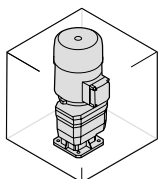

W = Default

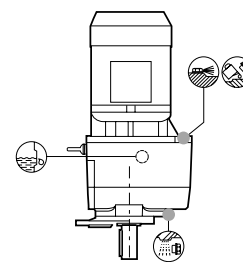
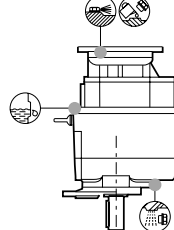
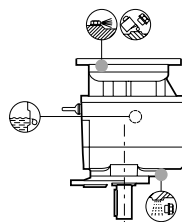
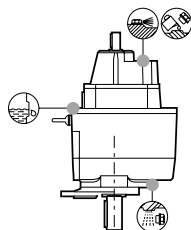
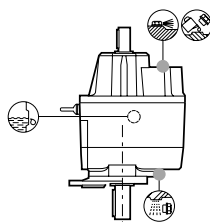

← 2x  
3x

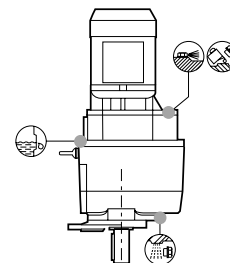

← 4x

### V3

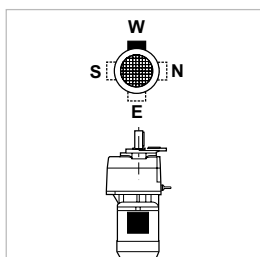
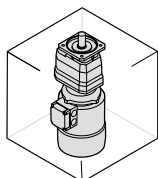

W = Default

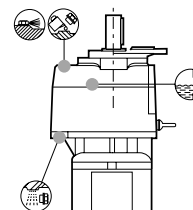
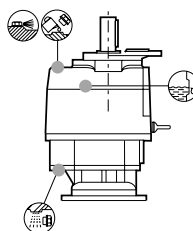
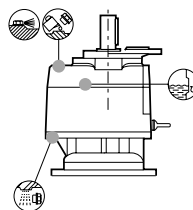
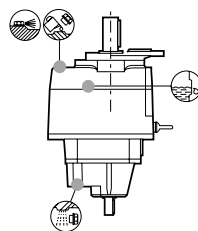
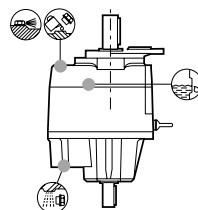

← 2x  
3x

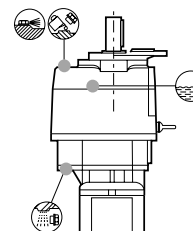

← 4x

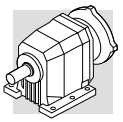

# C 70...C 100

## C\_P

(B13)

**\_HS**

**\_P (IEC)**

**\_S**

**B3**

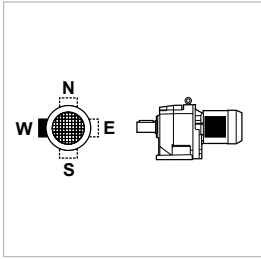
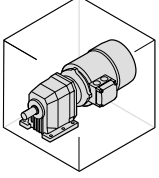

W = Default

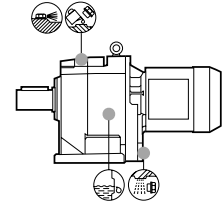
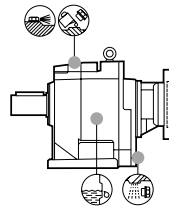
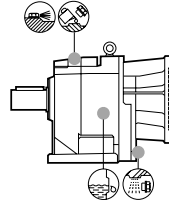
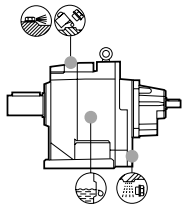
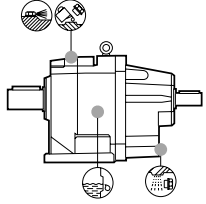

2x  
3x

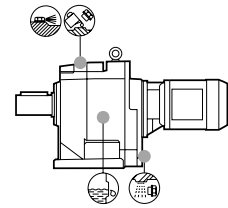

4x

**B6**

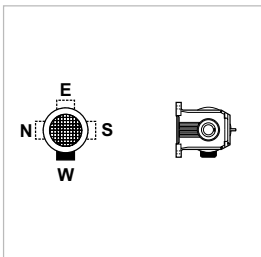
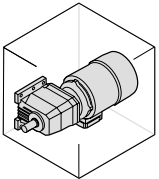

W = Default

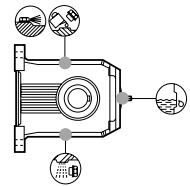
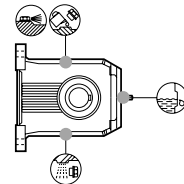
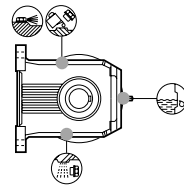
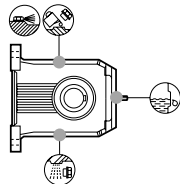
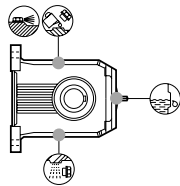

2x  
3x

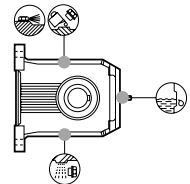

4x

**B7**

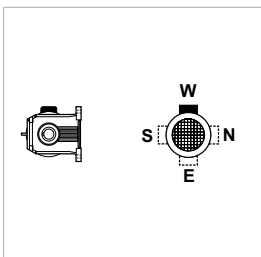
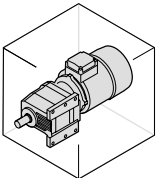

W = Default

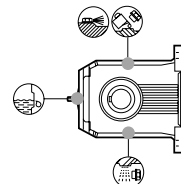
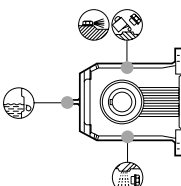
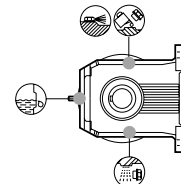
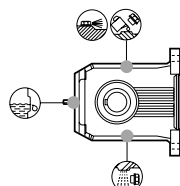
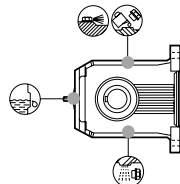

2x  
3x

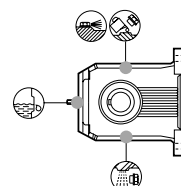

4x

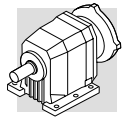

## C\_P

(B14)

**\_HS**

**\_P (IEC)**

**\_S**

**B8**

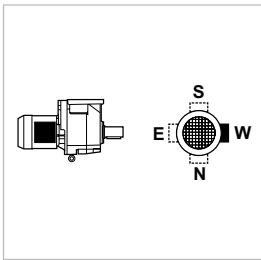
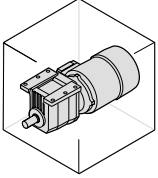

W = Default

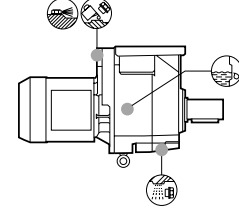
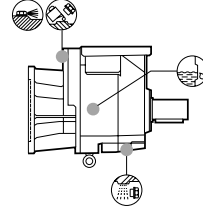
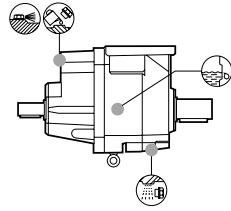

2x  
3x

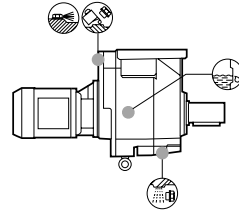
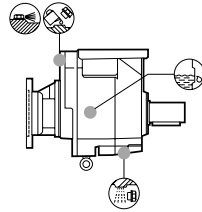
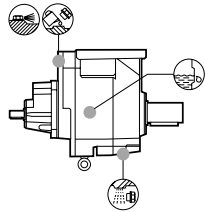

4x

**V5**

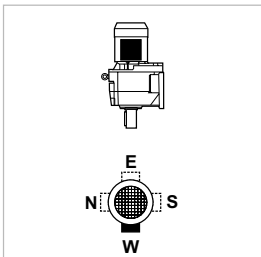
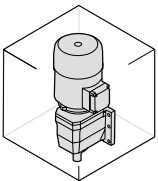

W = Default

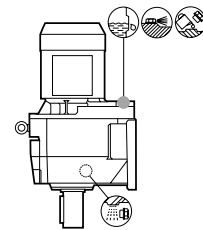
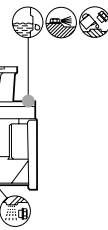
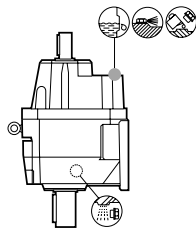

2x  
3x

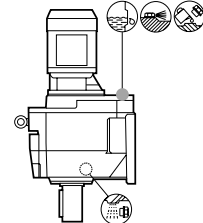
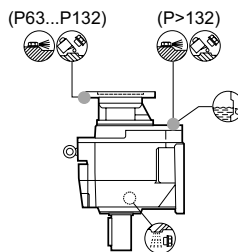
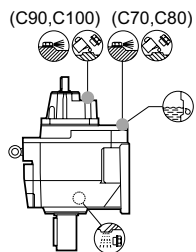

4x

**V6**

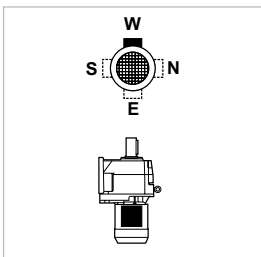
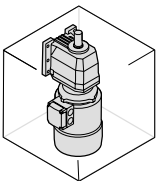

W = Default

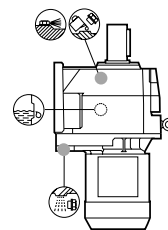
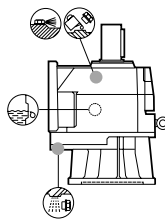
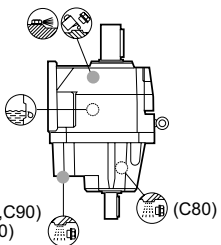

2x  
3x

(C70, C90) (C80)  
(C100)

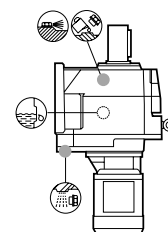
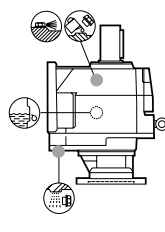
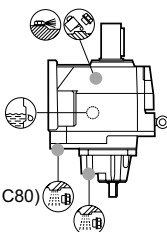

4x

(C70, C80)  
(C90, C100)

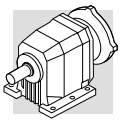

# C 70...C 100

## C\_F

(B15)

**\_HS**

**\_P (IEC)**

**\_S**

### B5

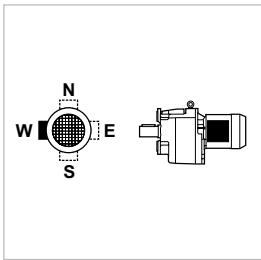
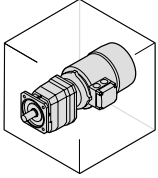

W = Default

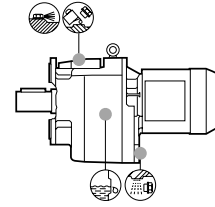
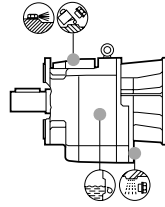
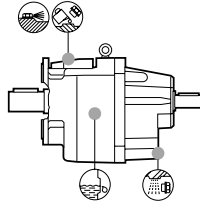

2x  
3x

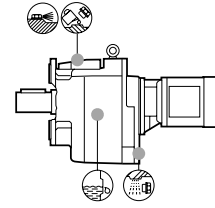
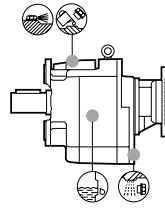
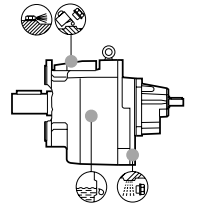

4x

### B51

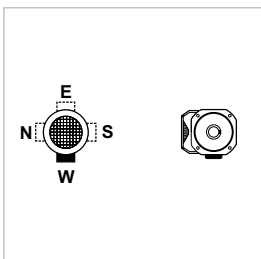
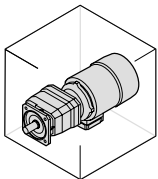

W = Default

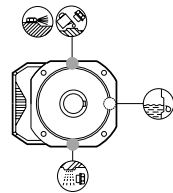
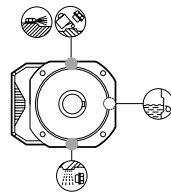
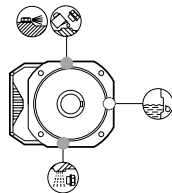

2x  
3x

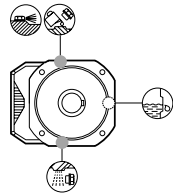
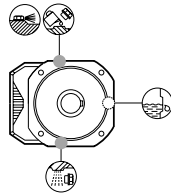
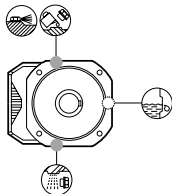

4x

### B53

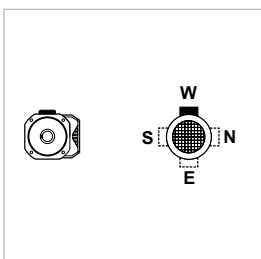
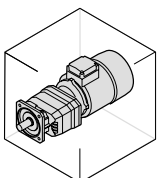

W = Default

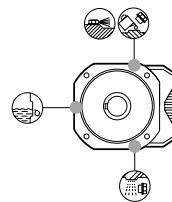
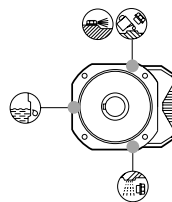
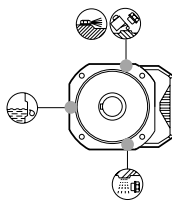

2x  
3x

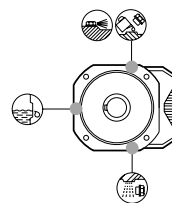
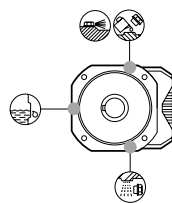
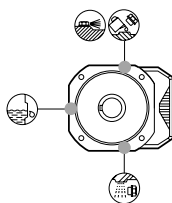

4x

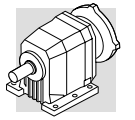

## C\_F

(B16)

**\_HS**

**\_P (IEC)**

**\_S**

### B52

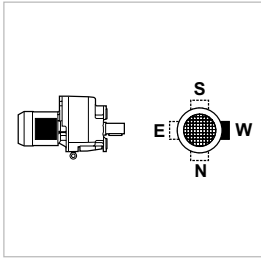
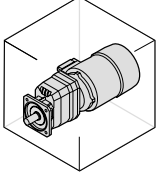

W = Default

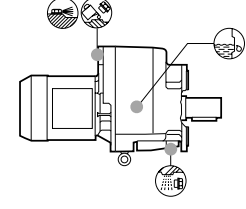
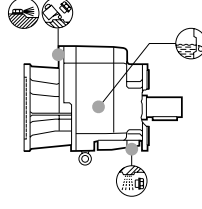
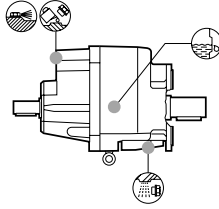

2x  
3x

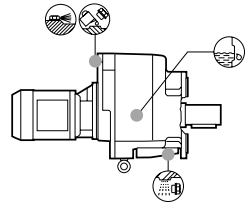
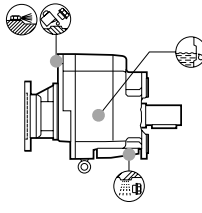
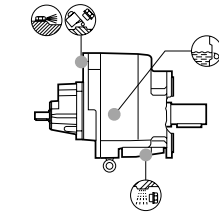

4x

### V1

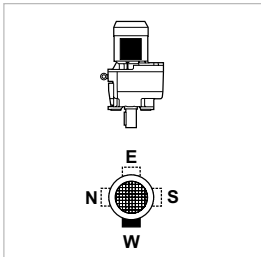
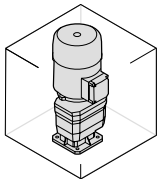

W = Default

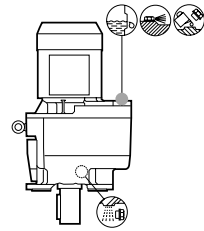
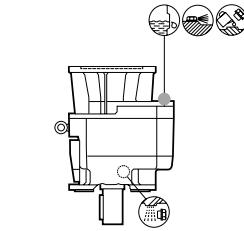
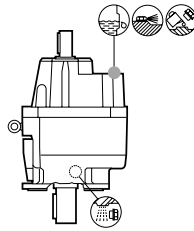

2x  
3x

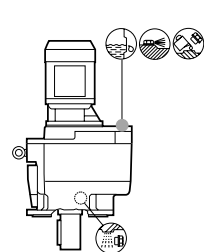
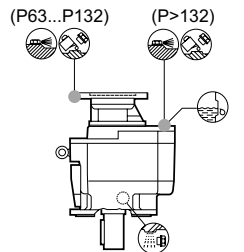
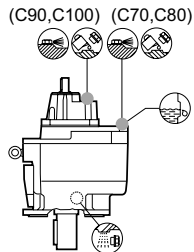

4x

### V3

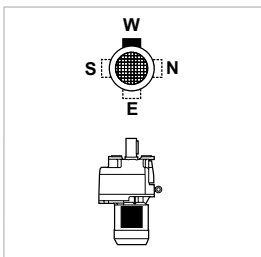
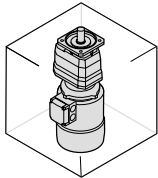

W = Default

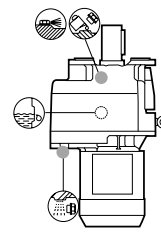
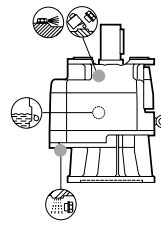
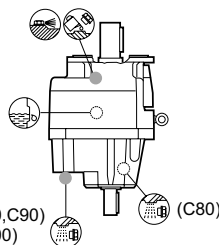

2x  
3x

(C70,C90)  
(C100) (C80)

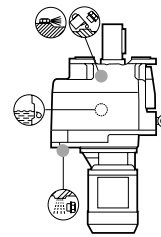
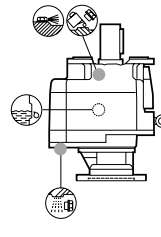
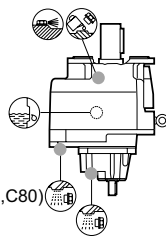

4x

(C70,C80)  
(C90,C100)

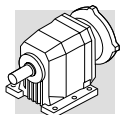

## 22 - CARICHI RADIALI

Organi di trasmissione calettati sugli alberi di ingresso e/o di uscita del riduttore generano forze la cui risultante agisce in senso radiale sull'albero stesso. L'entità di questi carichi deve essere compatibile con la capacità di sopportazione del sistema albero-cuscinetti del riduttore, in particolare il valore assoluto del carico applicato ( $R_{c1}$  per albero di ingresso,  $R_{c2}$  per albero di uscita) deve essere inferiore al valore nominale ( $R_{n1}$  per albero di ingresso,  $R_{n2}$  per albero di uscita) riportato nelle tabelle dati tecnici.

Nelle formule che seguono l'indice (1) si riferisce a grandezze relative all'albero veloce, l'indice (2) all'albero lento.

Il carico generato da una trasmissione esterna può essere calcolato, con buona approssimazione, tramite la formula seguente:

## 22 - OVERHUNG LOADS

*External transmissions keyed onto input and/or output shaft generate loads that act radially onto same shaft.*

*Resulting shaft loading must be compatible with both the bearing and the shaft capacity. Namely shaft loading ( $R_{c1}$  for input shaft,  $R_{c2}$  for output shaft), must be equal or lower than admissible overhung load capacity for shaft under study ( $R_{n1}$  for input shaft,  $R_{n2}$  for output shaft). OHL capability listed in the rating chart section.*

*In the formulas given below, index (1) applies to parameters relating to input shaft, whereas index (2) refers to output shaft.*

*The load generated by an external transmission can be calculated with close approximation by the following equations:*

## 22 - RADIALKRÄFTE

Die mit den Antriebs- und/oder Abtriebswellen des Getriebes verbundenen Antriebsorgane bilden Kräfte, die in radiale Richtung auf die Welle selbst wirken. Das Ausmaß dieser Kräfte muß mit der Festigkeit des Systems aus Getriebewelle/-lager kompatibel sein, insbesondere muß der absolute Wert der angetragenen Belastung ( $R_{c1}$  für Antriebswelle und  $R_{c2}$  für Abtriebswelle) unter dem in den Tabellen der Technischen Daten angegebenen Nennwert ( $R_{n1}$  für Antriebswelle und  $R_{n2}$  für Abtriebswelle) liegen.

In den nachstehenden Formeln bezieht sich die Angabe (1) auf die Maße der Antriebswelle, die Angabe (2) auf die Abtriebswelle. Die von einem externen Antrieb erzeugte Kraft kann, recht genau, anhand der nachstehenden Formel berechnet werden:

## 22 - CHARGES RADIALES

*Les organes de transmission calés sur les arbres d'entrée et/ou de sortie du réducteur génèrent des forces dont la résultante agit sur l'arbre dans le sens radial.*

*L'entité de ces charges doit être compatible avec la capacité d'endurance du système arbre-roulements du réducteur. Plus particulièrement, la valeur absolue de la charge appliquée ( $R_{c1}$  pour l'arbre d'entrée,  $R_{c2}$  pour l'arbre de sortie) doit être inférieure à la valeur nominale ( $R_{n1}$  pour l'arbre d'entrée,  $R_{n2}$  pour l'arbre de sortie) indiquée dans les tableaux des données techniques.*

*Dans les formules qui suivent, l'indice (1) se réfère à des tailles relatives à l'arbre rapide, l'indice (2) concerne l'arbre lent. La charge générée par une transmission extérieure peut être calculée, avec une bonne approximation, au moyen de la formule suivante:*

$$R_{c1} [N] = \frac{2000 \cdot M_1 [Nm] \cdot K_r}{d [mm]} ; R_{c2} [N] = \frac{2000 \cdot M_2 [Nm] \cdot K_r}{d [mm]} \quad (16)$$

dove:

$M_{1,2} [Nm]$  = coppia applicata all'albero

$d [mm]$  = diametro primitivo organo calettato

$K_r = 1$  trasmissione con catena

$K_r = 1,25$  trasmissione ad ingranaggio

$K_r = 1,5-2,0$  trasmissione a cinghia

where:

$M_{1,2} [Nm]$  = torque applied to shaft

$d [mm]$  = pitch diameter of part keyed on to shaft

$K_r = 1$  chain transmission

$K_r = 1,25$  gear transmission

$K_r = 1,5-2,0$  belt transmission

dabei:

$M_{1,2} [Nm]$  = Drehmoment an der Welle

$d [mm]$  = Teilkreisdurchmes ser des aufgekeilten Organs

$K_r = 1$  Kettenantrieb

$K_r = 1,25$  Zahnradantrieb

$K_r = 1,5-2,0$  Antrieb über Keilriemen

où:

$M_{1,2} [Nm]$  = couple appliqué à l'arbre

$d [mm]$  = diamètre primitif organe calé

$K_r = 1$  transmission avec chaîne

$K_r = 1,25$  transmission à engrenage

$K_r = 1,5-2,0$  transmission à courroie

In base al punto di applicazione del carico sull'albero la verifica di compatibilità procederà in modi diversi e in particolare:

*Verification of OHL capability varies depending on whether load applies at midpoint of shaft or it is shifted further out.*

In Abhängigkeit zum Kraftangriffspunkt an der Welle erfolgt die Kontrolle hinsichtlich der Kompatibilität in unterschiedlicher Weise und insbesondere:

*En fonction du point d'application de la charge sur l'arbre, la vérification de la compatibilité sera différente, plus particulièrement:*

(B17)

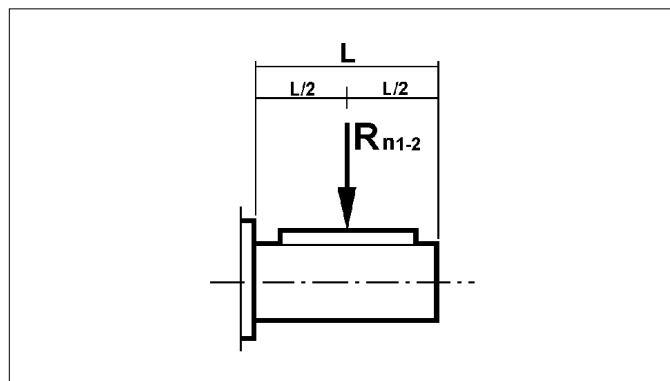

(B18)

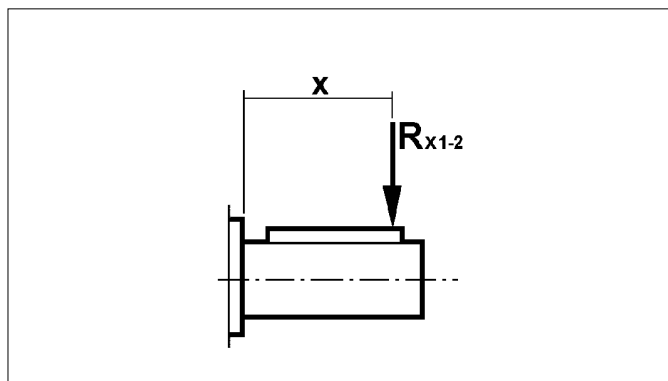

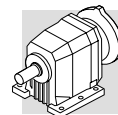

**a) Applicazione in mezzeria, tab. (B17)**

Il carico precedentemente calcolato si dovrà confrontare con il corrispondente valore nominale esposto a catalogo e dovrà verificarsi:

$$R_{c1} \leq R_{n1} \text{ [albero veloce]}$$

oppure

$$R_{c2} \leq R_{n2} \text{ [albero lento]}$$

**a) Load applied at midpoint of shaft, tab.(B17)**

*A comparison of shaft loading with catalogue OHL ratings should verify the following condition:*

$$R_{c1} \leq R_{n1} \text{ [input shaft]}$$

or

$$R_{c2} \leq R_{n2} \text{ [output shaft]}$$

**a) Kraftangriffspunkt in der Mitte, Tab. (B17)**

Der zuvor errechnete Wert muß mit dem im Katalog angegebenen Nennwert verglichen werden. Es muß sich folgendes ergeben:

$$R_{c1} \leq R_{n1} \text{ [Antriebswelle]}$$

oder

$$R_{c2} \leq R_{n2} \text{ [Abtriebswelle]}$$

**a) Application au milieu, tab. (B17)**

*La charge précédemment calculée doit être comparée avec la valeur nominale correspondante indiquée dans le catalogue, on doit vérifier :*

$$R_{c1} \leq R_{n1} \text{ [arbre rapide]}$$

ou

$$R_{c2} \leq R_{n2} \text{ [arbre lent]}$$

**b) Applicazione spostata dalla mezzeria, tab. (B18)**

L'applicazione del carico ad una distanza "x" dalla battuta dell'albero comporta il ricalcolo del valore ammissibile a detta distanza.

Il nuovo valore è individuato con i simboli  $R_{x1}$  (ingresso) e  $R_{x2}$  (uscita) e si ricava dai valori di catalogo, rispettivamente  $R_{n1}$  e  $R_{n2}$ , tramite l'elaborazione del fattore:

**b) Load off the midpoint tab. (B18)**

*When load is shifted at an "x" distance from shaft shoulder, permissible load must be calculated for that distance.*

*Revised permissible overhung loads  $R_{x1}$  (input) and  $R_{x2}$  (output) are calculated respectively from original rated values  $R_{n1}$  and  $R_{n2}$  through factor:*

**b) Von der Mitte versetzter Kraftangriffspunkt Tab. (B18)**

Der auf einer Distanz "x" vom Wellenansatz liegende Kraftangriffspunkt fordert eine erneute Berechnung des für diesen Abstand zulässigen Werts.

Der neue Wert wird mit den Symbolen  $R_{x1}$  (Antrieb) und  $R_{x2}$  (Abtrieb) gekennzeichnet und unter Anwendung der nachstehenden Faktorenberechnung aus den Katalog-werten  $R_{n1}$  und  $R_{n2}$ :

**b) Application déplacée du milieu, tab. (B18)**

*L'application de la charge à une distance "x" de la butée de l'arbre implique un nouveau calcul de la valeur admissible à cette distance.*

*La nouvelle valeur est indiquée par les symboles  $R_{x1}$  (entrée) et  $R_{x2}$  (sortie) ou peut être calculée d'après les valeurs de catalogue, respectivement  $R_{n1}$  et  $R_{n2}$ , en élaborant le facteur :*

$$\frac{a}{b+x} \quad (17)$$

(B19)

	Costanti del riduttore / Load location factors / Getriebekonstanten / Constantes du réducteur					
	Albero lento / Output shaft Abtriebswelle / Arbre lent			Albero veloce / Input shaft Antriebswelle / Arbre rapide		
	a	b	c	a	b	c
C 05 2	38	18	250	—	—	—
C 11 2	46	26	450	21	1	300
C 21 2	53	28	550	40	20	350
C 21 3	53	28	550	21	1	300
C 31 2	60.5	30.5	750	41.5	21.5	350
C 31 3	60.5	30.5	750	21	1	300
C 35 2 - C 35 3	69.5	34.5	800	51.5	26.5	450
C 35 4	69.5	34.5	800	21	1	300
C 41 2 - C 41 3	69.5	34.5	850	51.5	26.5	450
C 41 4	69.5	34.5	850	40	20	350
C 51 2 - C 51 3	76.5	36.5	900	51.5	26.5	450
C 51 4	76.5	36.5	900	41.5	21.5	350
C 61 2 - C 61 3	95.5	45.5	1000	57.5	27.5	450
C 61 4	95.5	45.5	1000	51.5	26.5	450
C 70 2 - C 70 3	114	54	1200	86	31	1000
C 70 4	114	54	1200	49.5	24.5	450
C 80 2 - C 80 3	131	61	1500	86	31	1000
C 80 4	131	61	1500	49.5	24.5	450
C 90 2 - C 90 3	161	76	2000	116	46	1400
C 90 4	161	76	2000	49.5	24.5	450
C 100 2 - C 100 3	163.5	58.5	2500	116	46	1400
C 100 4	163.5	58.5	2500	49.5	24.5	450



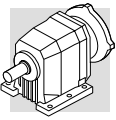

La procedura di verifica comporta passi successivi che sono qui descritti.

*Verification procedure is described here after.*

Das Kontrollverfahren zieht die nachstehend beschriebenen Schritte nach sich.

*La procédure de vérification comporte les pas successifs indiqués ici.*

#### ALBERO VELOCE

#### INPUT SHAFT

#### ANTRIEBSWELLE

#### ARBRE RAPIDE

1. Calcolo di:

1. Calculate:

1. Berechnung von:

1. Calcul de:

$$R_{x1} = R_{n1} \cdot \frac{a}{b+x} \quad (18)$$

$$\frac{L}{2} \leq x \leq c \quad (19)$$

Infine si dovrà verificare che:

*Finally, the following condition must be verified:*

Dies als Voraussetzung, muß sich folgendes ergeben:

*Ensuite, vérifier que:*

$$R_{c1} \leq R_{x1} \quad (20)$$

#### ALBERO LENTO

#### OUTPUT SHAFT

#### ABTRIEBSWELLE

#### ARBRE LENT

1. Calcolo di:

1. Calculate:

1. Berechnung von:

1. Calcul de:

$$R_{x2} = R_{n2} \cdot \frac{a}{b+x} \quad (21)$$

N.B. A condizione che:

*N.B. Subject to condition:*

HINWEIS unter der Bedingung, daß:

*N.B. A condition que:*

$$\frac{L}{2} \leq x \leq c \quad (22)$$

Infine si dovrà verificare che:

*Finally, the following condition must be verified:*

Dies als Voraussetzung, muß sich folgendes ergeben:

*Ensuite, vérifier que:*

$$R_{c2} \leq R_{x2} \quad (23)$$

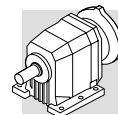

### 23 - CARICHI ASSIALI, $A_{n1}, A_{n2}$

I valori di carico assiale ammissibile sugli alberi veloce  $[A_{n1}]$  e lento  $[A_{n2}]$  si possono ricavare con riferimento al corrispondente valore di carico radiale  $[R_{n1}]$  e  $[R_{n2}]$  tramite le espressioni che seguono:

### 23 - THRUST LOADS, $A_{n1}, A_{n2}$

*Permissible thrust loads on input  $[A_{n1}]$  and output  $[A_{n2}]$  shafts are obtained from the radial loading for the shaft under consideration  $[R_{n1}]$  and  $[R_{n2}]$  through the following equation:*

### 23 - AXIALKRÄFTE, $A_{n1}, A_{n2}$

Die Werte der zulässigen, auf die Antriebswelle  $[A_{n1}]$  und auf die Abtriebswelle  $[A_{n2}]$  einwirkenden Axialkräfte können unter Bezugnahme auf den jeweiligen Wert der Radialkraft  $[R_{n1}]$  und  $[R_{n2}]$  anhand der nachstehenden Angaben berechnet werden:

### 23 - CHARGES AXIALES, $A_{n1}, A_{n2}$

*Les valeurs de charge axiale admissible sur les arbres rapides  $[A_{n1}]$  et lent  $[A_{n2}]$  peuvent être calculées, en se référant à la valeur de charge radiale correspondante  $[R_{n1}]$  et  $[R_{n2}]$  au moyen des formules suivantes :*

$$A_{n1} = R_{n1} \cdot 0,2$$

$$A_{n2} = R_{n2} \cdot 0,2$$

(24)

I valori di carico assiale ammissibile così calcolati si riferiscono al caso di forze assiali agenti contemporaneamente ai carichi radiali nominali.

Nel solo caso in cui il valore del carico radiale agente sull'albero del riduttore sia nullo, si può considerare il carico assiale ammissibile  $[A_n]$  pari al 50% del valore di carico radiale ammissibile  $[R_n]$  sullo stesso albero.

In presenza di carichi assiali eccedenti il valore ammissibile, o di forze assiali fortemente prevalenti sui carichi radiali, è consigliabile contattare il Servizio Tecnico di Bonfiglioli Riduttori per una verifica puntuale.

*The thrust loads calculated through these formulas apply to thrust forces occurring at the same time as rated radial loads. In the only case that no overhung load acts on the shaft the value of the admissible thrust load  $[A_n]$  amounts to 50% of rated OHL  $[R_n]$  on same shaft. Where thrust loads exceed permissible value or largely prevail over radial loads, contact Bonfiglioli Riduttori for an in-depth analysis of the application.*

Die so errechneten Werte der zulässigen Axialkräfte beziehen sich auf den Fall, in dem die Axialkräfte gleichzeitig mit den Nennradialkräften einwirken.

Nur im Fall, es keine Radialbelastung auf die Getriebewelle gibt, ist der Wert der zulässigen Axialbelastung  $[A_n]$  gleich zu 50% der zulässigen Radialbelastung  $[R_n]$  auf die gleiche Welle.

In Anwesenheit von übermäßigen Axialkräften, oder stark auf die Radialkräfte einwirkende Kräfte, wird im Hinblick auf eine genaue Kontrolle empfohlen, sich mit dem Technischen Kundendienst der Bonfiglioli Riduttori in Verbindung zu setzen.



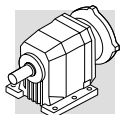

*Les valeurs de charge axiale admissible ainsi calculées se réfèrent au cas de forces axiales agissant en même temps que les charges radiales nominales.*

*Dans le seul cas la valeur de la charge radiale agissant sur l'arbre soit nul, l'on peut considérer la charge axiale admissible  $[A_n]$  égale à 50% de la valeur de la charge radiale admissible  $[R_n]$  sur le même arbre.*

*En présence de charges axiales excédant la valeur admissible, ou de forces axiales fortement supérieures aux charges radiales, il est conseillé de contacter le Service Technique Bonfiglioli Riduttori pour une vérification.*

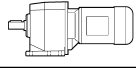

## 0.09 kW



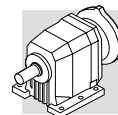

$n_2$ min <sup>-1</sup>	$M_2$ Nm	S	i	$R_{n2}$ N				
1.0	760	0.8	855.5	7000	C414_ 855.5 S05 M05A6	123	C414_ 855.5 P63 BN63A6	124
1.2	654	0.9	735.9	7000	C414_ 735.9 S05 M05A6	123	C414_ 735.9 P63 BN63A6	124
1.3	597	1.0	671.3	7000	C414_ 671.3 S05 M05A6	123	C414_ 671.3 P63 BN63A6	124
1.5	511	0.9	574.7	6500	C354_ 574.7 S05 M05A6	120	C354_ 574.7 P63 BN63A6	121
1.6	483	1.2	543.5	7000	C414_ 543.5 S05 M05A6	123	C414_ 543.5 P63 BN63A6	124
1.9	407	1.1	458.4	6500	C354_ 458.4 S05 M05A6	120	C354_ 458.4 P63 BN63A6	121
2.0	400	1.5	450.2	7000	C414_ 450.2 S05 M05A6	123	C414_ 450.2 P63 BN63A6	124
2.6	306	1.5	344.3	6500	C354_ 344.3 S05 M05A6	120	C354_ 344.3 P63 BN63A6	121
2.6	296	2.0	333.4	7000	C414_ 333.4 S05 M05A6	123	C414_ 333.4 P63 BN63A6	124
3.2	250	1.1	274.7	5500	C313_ 274.7 S05 M05A6	117	C313_ 274.7 P63 BN63A6	118
3.9	205	1.0	225.8	5000	C213_ 225.8 S05 M05A6	114	C213_ 225.8 P63 BN63A6	115
4.1	196	1.5	215.6	5500	C313_ 215.6 S05 M05A6	117	C313_ 215.6 P63 BN63A6	118
4.9	162	1.2	178.5	5000	C213_ 178.5 S05 M05A6	114	C213_ 178.5 P63 BN63A6	115
5.8	138	1.5	151.7	5000	C213_ 151.7 S05 M05A6	114	C213_ 151.7 P63 BN63A6	115
5.9	135	2.2	148.4	5500	C313_ 148.4 S05 M05A6	117	C313_ 148.4 P63 BN63A6	118
7.2	111	1.8	122.2	5000	C213_ 122.2 S05 M05A6	114	C213_ 122.2 P63 BN63A6	115
7.2	111	2.7	122.4	5500	C313_ 122.4 S05 M05A6	117	C313_ 122.4 P63 BN63A6	118
8.0	100	2.0	110.0	5000	C213_ 110.0 S05 M05A6	114	C213_ 110.0 P63 BN63A6	115
8.8	91	2.2	100.2	5000	C213_ 100.2 S05 M05A6	114	C213_ 100.2 P63 BN63A6	115
10.7	75	2.7	82.6	5000	C213_ 82.6 S05 M05A6	114	C213_ 82.6 P63 BN63A6	115
13.3	61	1.5	66.2	2000	C112_ 66.2 S05 M05A6	111	C112_ 66.2 P63 BN63A6	112
14.8	55	1.5	59.6	2000	C112_ 59.6 S05 M05A6	111	C112_ 59.6 P63 BN63A6	112
16.0	51	1.8	55.2	2000	C112_ 55.2 S05 M05A6	111	C112_ 55.2 P63 BN63A6	112
17.7	46	2.2	49.7	2000	C112_ 49.7 S05 M05A6	111	C112_ 49.7 P63 BN63A6	112
18.5	44	2.0	47.6	2000	C112_ 47.6 S05 M05A6	111	C112_ 47.6 P63 BN63A6	112
19.7	42	1.1	44.7	1170	C052_ 44.7 S05 M05A6	110		
21.8	38	1.2	40.3	1150	C052_ 40.3 S05 M05A6	110		
23.8	34	2.6	37.0	2000	C112_ 37.0 S05 M05A6	111	C112_ 37.0 P63 BN63A6	112
24.2	34	1.3	36.4	1140	C052_ 36.4 S05 M05A6	110		
26.8	31	1.5	32.8	1110	C052_ 32.8 S05 M05A6	110		
30	27	1.7	44.7	1170	C052_ 44.7 S0 M0B4	110		
33	25	1.8	40.3	990	C052_ 40.3 S0 M0B4	110		
37	22	2.0	36.4	980	C052_ 36.4 S0 M0B4	110		
41	20	2.3	32.8	960	C052_ 32.8 S0 M0B4	110		
42	19	2.3	21.0	1020	C052_ 21.0 S05 M05A6	110		
50	16	2.7	27.1	930	C052_ 27.1 S0 M0B4	110		
56	15	3.1	15.6	950	C052_ 15.6 S05 M05A6	110		
66	12	6.5	13.4	2000	C112_ 13.4 S05 M05A6	111	C112_ 13.4 P63 BN63A6	112
71	12	3.9	12.5	900	C052_ 12.5 S05 M05A6	110		
78	10	4.3	11.2	880	C052_ 11.2 S05 M05A6	110		
88	9	7.7	10.1	2000	C112_ 10.1 S05 M05A6	111	C112_ 10.1 P63 BN63A6	112
95	9	5.2	9.3	830	C052_ 9.3 S05 M05A6	110		
119	7	6.5	7.4	780	C052_ 7.4 S05 M05A6	110		
132	6	7.3	6.7	760	C052_ 6.7 S05 M05A6	110		
146	6	10.9	6.2	1960	C112_ 6.2 S05 M05A6	111	C112_ 6.2 P63 BN63A6	112
159	5	8.8	5.5	720	C052_ 5.5 S05 M05A6	110		
187	4	12.6	4.9	1810	C112_ 4.9 S05 M05A6	111	C112_ 4.9 P63 BN63A6	112
249	3	15.0	3.7	1650	C112_ 3.7 S05 M05A6	111	C112_ 3.7 P63 BN63A6	112
329	2	17.3	2.8	1510	C112_ 2.8 S05 M05A6	111	C112_ 2.8 P63 BN63A6	112

## 0.12 kW

0.98	1061	0.9	884.9	10000			C514_ 884.9 P63 BN63B6	127
1.2	860	1.2	717.7	10000			C514_ 717.7 P63 BN63B6	127
1.5	681	0.9	855.5	7000	C414_ 855.5 S05 M05A4	123	C414_ 855.5 P63 BN63A4	124
1.6	643	1.6	808.0	10000			C514_ 808.0 P63 BN63A4	127
1.7	621	1.0	780.4	7000	C414_ 780.4 S05 M05A4	123	C414_ 780.4 P63 BN63A4	124
1.8	586	1.0	735.9	7000	C414_ 735.9 S05 M05A4	123	C414_ 735.9 P63 BN63A4	124
2.0	534	1.1	671.3	7000	C414_ 671.3 S05 M05A4	123	C414_ 671.3 P63 BN63A4	124
2.0	530	0.8	665.9	6500	C354_ 665.9 S05 M05A4	120	C354_ 665.9 P63 BN63A4	121
2.2	483	0.9	606.6	6500	C354_ 606.6 S05 M05A4	120	C354_ 606.6 P63 BN63A4	121
2.2	474	1.3	595.8	7000	C414_ 595.8 S05 M05A4	123	C414_ 595.8 P63 BN63A4	124

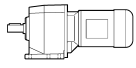



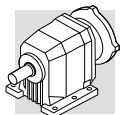

## 0.12 kW

$n_2$ min <sup>-1</sup>	$M_2$ Nm	S	i	$R_{n2}$ N			 IEC	
2.3	457	1.0	574.7	6500	C354_ 574.7 S05 M05A4	120	C354_ 574.7 P63 BN63A4	121
2.4	433	1.4	543.5	7000	C414_ 543.5 S05 M05A4	123	C414_ 543.5 P63 BN63A4	124
2.5	417	1.1	523.5	6500	C354_ 523.5 S05 M05A4	120	C354_ 523.5 P63 BN63A4	121
2.7	393	1.5	493.5	7000	C414_ 493.5 S05 M05A4	123	C414_ 493.5 P63 BN63A4	124
2.9	365	1.2	458.4	6500	C354_ 458.4 S05 M05A4	120	C354_ 458.4 P63 BN63A4	121
2.9	358	1.7	450.2	7000	C414_ 450.2 S05 M05A4	123	C414_ 450.2 P63 BN63A4	124
3.1	333	1.8	418.5	7000	C414_ 418.5 S05 M05A4	123	C414_ 418.5 P63 BN63A4	124
3.1	332	1.4	417.6	6500	C354_ 417.6 S05 M05A4	120	C354_ 417.6 P63 BN63A4	121
3.4	304	2.0	381.8	7000	C414_ 381.8 S05 M05A4	123	C414_ 381.8 P63 BN63A4	124
3.5	301	1.5	377.9	6500	C354_ 377.9 S05 M05A4	120	C354_ 377.9 P63 BN63A4	121
3.8	274	1.6	344.3	6500	C354_ 344.3 S05 M05A4	120	C354_ 344.3 P63 BN63A4	121
3.9	265	2.3	333.4	7000	C414_ 333.4 S05 M05A4	123	C414_ 333.4 P63 BN63A4	124
4.1	254	1.8	318.9	6500	C354_ 318.9 S05 M05A4	120	C354_ 318.9 P63 BN63A4	121
4.3	242	2.5	304.2	7000	C414_ 304.2 S05 M05A4	123	C414_ 304.2 P63 BN63A4	124
4.8	223	1.1	274.7	5500	C313_ 274.7 S05 M05A4	117	C313_ 274.7 P63 BN63A4	118
4.9	219	0.9	178.5	5000	C213_ 178.5 S05 M05B6	114	C213_ 178.5 P63 BN63B6	115
5.0	209	2.9	263.0	7000	C414_ 263.0 S05 M05A4	123	C414_ 263.0 P63 BN63A4	124
5.3	201	1.1	247.3	5500	C313_ 247.3 S05 M05A4	117	C313_ 247.3 P63 BN63A4	118
5.4	197	1.0	160.7	5000	C213_ 160.7 S05 M05B6	114	C213_ 160.7 P63 BN63B6	115
5.8	184	1.0	225.8	5000	C213_ 225.8 S05 M05A4	114	C213_ 225.8 P63 BN63A4	115
6.1	175	1.7	215.6	5500	C313_ 215.6 S05 M05A4	117	C313_ 215.6 P63 BN63A4	118
6.4	165	1.0	203.2	5000	C213_ 203.2 S05 M05A4	114	C213_ 203.2 P63 BN63A4	115
6.7	158	1.9	194.1	5500	C313_ 194.1 S05 M05A4	117	C313_ 194.1 P63 BN63A4	118
7.3	145	1.4	178.5	5000	C213_ 178.5 S05 M05A4	114	C213_ 178.5 P63 BN63A4	115
7.8	136	2.2	167.5	5500	C313_ 167.5 S05 M05A4	117	C313_ 167.5 P63 BN63A4	118
8.2	131	1.5	160.7	5000	C213_ 160.7 S05 M05A4	114	C213_ 160.7 P63 BN63A4	115
8.6	123	1.6	151.7	5000	C213_ 151.7 S05 M05A4	114	C213_ 151.7 P63 BN63A4	115
8.8	121	2.5	148.4	5500	C313_ 148.4 S05 M05A4	117	C313_ 148.4 P63 BN63A4	118
9.6	111	1.8	136.5	5000	C213_ 136.5 S05 M05A4	114	C213_ 136.5 P63 BN63A4	115
9.8	109	2.8	133.6	5500	C313_ 133.6 S05 M05A4	117	C313_ 133.6 P63 BN63A4	118
10.7	99	2.0	122.2	5000	C213_ 122.2 S05 M05A4	114	C213_ 122.2 P63 BN63A4	115
10.7	100	3.0	122.4	5500	C313_ 122.4 S05 M05A4	117	C313_ 122.4 P63 BN63A4	118
11.9	89	2.2	110.0	5000	C213_ 110.0 S05 M05A4	114	C213_ 110.0 P63 BN63A4	115
13.1	81	2.5	100.2	5000	C213_ 100.2 S05 M05A4	114	C213_ 100.2 P63 BN63A4	115
14.5	73	2.7	90.2	5000	C213_ 90.2 S05 M05A4	114	C213_ 90.2 P63 BN63A4	115
15.9	67	3.0	82.6	5000	C213_ 82.6 S05 M05A4	114	C213_ 82.6 P63 BN63A4	115
19.8	55	1.6	66.2	2000	C112_ 66.2 S05 M05A4	111	C112_ 66.2 P63 BN63A4	112
22.0	50	1.7	59.6	2000	C112_ 59.6 S05 M05A4	111	C112_ 59.6 P63 BN63A4	112
23.0	47	2.4	57.0	5000	C212_ 57.0 S05 M05A4	114	C212_ 57.0 P63 BN63A4	115
23.7	46	2.0	55.2	2000	C112_ 55.2 S05 M05A4	111	C112_ 55.2 P63 BN63A4	112
26.4	41	2.4	49.7	2000	C112_ 49.7 S05 M05A4	111	C112_ 49.7 P63 BN63A4	112
27.5	40	2.3	47.6	2000	C112_ 47.6 S05 M05A4	111	C112_ 47.6 P63 BN63A4	112
29.3	37	1.2	44.7	1010	C052_ 44.7 S05 M05A4	110		
31	36	2.8	42.9	2000	C112_ 42.9 S05 M05A4	111	C112_ 42.9 P63 BN63A4	112
33	34	1.3	40.3	990	C052_ 40.3 S05 M05A4	110		
35	31	2.9	37.0	2000	C112_ 37.0 S05 M05A4	111	C112_ 37.0 P63 BN63A4	112
36	30	1.5	36.4	980	C052_ 36.4 S05 M05A4	110		
39	28	3.6	33.4	2000	C112_ 33.4 S05 M05A4	111	C112_ 33.4 P63 BN63A4	112
40	27	1.6	32.8	960	C052_ 32.8 S05 M05A4	110		
48	23	2.0	27.1	930	C052_ 27.1 S05 M05A4	110		
56	20	2.3	15.6	900	C052_ 15.6 S05 M05B6	110		
62	18	2.6	21.0	890	C052_ 21.0 S05 M05A4	110		
69	16	2.5	18.9	860	C052_ 18.9 S05 M05A4	110		
78	14	3.2	11.2	850	C052_ 11.2 S05 M05B6	110		
84	13	3.1	15.6	820	C052_ 15.6 S05 M05A4	110		
105	10	3.8	12.5	780	C052_ 12.5 S05 M05A4	110		
117	9	4.3	11.2	760	C052_ 11.2 S05 M05A4	110		
130	8	5.4	6.7	740	C052_ 6.7 S05 M05B6	110		
141	8	3.9	9.3	720	C052_ 9.3 S05 M05A4	110		
177	6	4.8	7.4	680	C052_ 7.4 S05 M05A4	110		
196	6	5.4	6.7	660	C052_ 6.7 S05 M05A4	110		
225	5	10.9	6.2	1700	C112_ 6.2 S05 M05A4	111	C112_ 6.2 P63 BN63A4	112
288	4	12.7	4.9	1570	C112_ 4.9 S05 M05A4	111	C112_ 4.9 P63 BN63A4	112
383	3	14.8	3.7	1430	C112_ 3.7 S05 M05A4	111	C112_ 3.7 P63 BN63A4	112
506	2	17.2	2.8	1310	C112_ 2.8 S05 M05A4	111	C112_ 2.8 P63 BN63A4	112

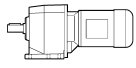



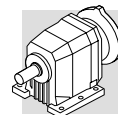

## 0.18 kW

$n_2$ min <sup>-1</sup>	$M_2$ Nm	S	i	$R_{n2}$ N				
0.66	2367	1.0	1362	25000			C704_ 1362 P71 BN71A6	133
0.84	1858	1.2	1069	25000			C704_ 1069 P71 BN71A6	133
1.2	1262	1.3	726.3	16000	C614_ 726.3 S1 M1SC6	129	C614_ 726.3 P71 BN71A6	130
1.3	1248	0.8	717.7	10000	C514_ 717.7 S1 M1SC6	126	C514_ 717.7 P71 BN71A6	127
1.5	1049	1.0	884.9	10000			C514_ 884.9 P63 BN63B4	127
1.6	958	1.0	808.0	10000			C514_ 808.0 P63 BN63B4	127
1.6	955	1.0	549.7	10000	C514_ 549.7 S1 M1SC6	126	C514_ 549.7 P71 BN71A6	127
1.8	861	1.9	726.3	16000			C614_ 726.3 P63 BN63B4	130
1.8	851	1.2	717.7	10000			C514_ 717.7 P63 BN63B4	127
1.9	806	1.2	463.9	10000	C514_ 463.9 S1 M1SC6	126	C514_ 463.9 P71 BN71A6	127
1.9	803	2.0	462.0	16000	C614_ 462.0 S1 M1SC6	129	C614_ 462.0 P71 BN71A6	130
2.0	796	0.8	671.3	7000	C414_ 671.3 S05 M05B4	123	C414_ 671.3 P63 BN63B4	124
2.0	783	0.8	450.2	7000	C414_ 450.2 S1 M1SC6	123	C414_ 450.2 P71 BN71A6	124
2.0	777	1.3	655.4	10000			C514_ 655.4 P63 BN63B4	127
2.2	727	0.8	418.5	7000	C414_ 418.5 S1 M1SC6	123	C414_ 418.5 P71 BN71A6	124
2.2	723	1.4	415.7	10000	C514_ 415.7 S1 M1SC6	126	C514_ 415.7 P71 BN71A6	127
2.2	706	0.8	595.8	7000	C414_ 595.8 S05 M05B4	123	C414_ 595.8 P63 BN63B4	124
2.4	660	1.5	379.6	10000	C514_ 379.6 S1 M1SC6	126	C514_ 379.6 P71 BN71A6	127
2.4	644	0.9	543.5	7000	C414_ 543.5 S05 M05B4	123	C414_ 543.5 P63 BN63B4	124
2.6	598	0.8	344.3	6500	C354_ 344.3 S1 M1SC6	120	C354_ 344.3 P71 BN71A6	121
2.7	585	1.0	493.5	7000	C414_ 493.5 S05 M05B4	123	C414_ 493.5 P63 BN63B4	124
2.9	543	0.8	458.4	6500	C354_ 458.4 S05 M05B4	120	C354_ 458.4 P63 BN63B4	121
2.9	534	1.1	450.2	7000	C414_ 450.2 S05 M05B4	123	C414_ 450.2 P63 BN63B4	124
3.2	496	1.2	418.5	7000	C414_ 418.5 S05 M05B4	123	C414_ 418.5 P63 BN63B4	124
3.2	495	0.9	417.6	6500	C354_ 417.6 S05 M05B4	120	C354_ 417.6 P63 BN63B4	121
3.5	452	1.3	381.8	7000	C414_ 381.8 S05 M05B4	123	C414_ 381.8 P63 BN63B4	124
3.5	448	1.0	377.9	6500	C354_ 377.9 S05 M05B4	120	C354_ 377.9 P63 BN63B4	121
3.8	408	1.1	344.3	6500	C354_ 344.3 S05 M05B4	120	C354_ 344.3 P63 BN63B4	121
4.0	395	1.5	333.4	7000	C414_ 333.4 S05 M05B4	123	C414_ 333.4 P63 BN63B4	124
4.1	378	1.2	318.9	6500	C354_ 318.9 S05 M05B4	120	C354_ 318.9 P63 BN63B4	121
4.3	371	1.6	209.1	7000	C413_ 209.1 S1 M1SC6	123	C413_ 209.1 P71 BN71A6	124
4.3	360	1.7	304.2	7000	C414_ 304.2 S05 M05B4	123	C414_ 304.2 P63 BN63B4	124
4.5	344	1.3	290.6	6500	C354_ 290.6 S05 M05B4	120	C354_ 290.6 P63 BN63B4	121
4.7	339	1.8	190.8	7000	C413_ 190.8 S1 M1SC6	123	C413_ 190.8 P71 BN71A6	124
4.8	334	1.3	188.0	6500	C353_ 188.0 S1 M1SC6	120	C353_ 188.0 P71 BN71A6	121
4.8	330	0.9	186.0	5500	C313_ 186.0 S1 M1SC6	117	C313_ 186.0 P71 BN71A6	118
5.0	312	1.9	263.0	7000	C414_ 263.0 S05 M05B4	123	C414_ 263.0 P63 BN63B4	124
5.2	302	1.5	255.0	6500	C354_ 255.0 S05 M05B4	120	C354_ 255.0 P63 BN63B4	121
5.4	298	1.0	167.5	5500	C313_ 167.5 S1 M1SC6	117	C313_ 167.5 P71 BN71A6	118
5.7	275	1.6	232.3	6500	C354_ 232.3 S05 M05B4	120	C354_ 232.3 P63 BN63B4	121
6.1	262	1.7	147.6	6500	C353_ 147.6 S1 M1SC6	120	C353_ 147.6 P71 BN71A6	121
6.1	261	1.1	215.6	5500	C313_ 215.6 S05 M05B4	117	C313_ 215.6 P63 BN63B4	118
6.8	235	1.3	194.1	5500	C313_ 194.1 S05 M05B4	117	C313_ 194.1 P63 BN63B4	118
7.4	216	0.9	178.5	5000	C213_ 178.5 S05 M05B4	114	C213_ 178.5 P63 BN63B4	115
7.9	203	1.5	167.5	5500	C313_ 167.5 S05 M05B4	117	C313_ 167.5 P63 BN63B4	118
8.7	184	1.1	151.7	5000	C213_ 151.7 S05 M05B4	114	C213_ 151.7 P63 BN63B4	115
8.9	180	1.7	148.4	5500	C313_ 148.4 S05 M05B4	117	C313_ 148.4 P63 BN63B4	118
9.7	165	1.2	136.5	5000	C213_ 136.5 S05 M05B4	114	C213_ 136.5 P63 BN63B4	115
9.9	162	1.9	133.6	5500	C313_ 133.6 S05 M05B4	117	C313_ 133.6 P63 BN63B4	118
10.8	148	1.4	122.2	5000	C213_ 122.2 S05 M05B4	114	C213_ 122.2 P63 BN63B4	115
10.8	148	2.0	122.4	5500	C313_ 122.4 S05 M05B4	117	C313_ 122.4 P63 BN63B4	118
12.0	133	1.5	110.0	5000	C213_ 110.0 S05 M05B4	114	C213_ 110.0 P63 BN63B4	115
12.0	133	2.2	110.2	5500	C313_ 110.2 S05 M05B4	117	C313_ 110.2 P63 BN63B4	118
12.8	125	2.4	103.3	5500	C313_ 103.3 S05 M05B4	117	C313_ 103.3 P63 BN63B4	118
13.2	121	1.6	100.2	5000	C213_ 100.2 S05 M05B4	114	C213_ 100.2 P63 BN63B4	115
14.2	113	2.7	93.0	5500	C313_ 93.0 S05 M05B4	117	C313_ 93.0 P63 BN63B4	118
14.6	109	1.8	90.2	5000	C213_ 90.2 S05 M05B4	114	C213_ 90.2 P63 BN63B4	115
16.0	100	2.0	82.6	5000	C213_ 82.6 S05 M05B4	114	C213_ 82.6 P63 BN63B4	115
16.0	100	3.0	82.6	5500	C313_ 82.6 S05 M05B4	117	C313_ 82.6 P63 BN63B4	118
17.8	90	2.2	74.4	5000	C213_ 74.4 S05 M05B4	114	C213_ 74.4 P63 BN63B4	115
20.0	82	1.1	66.2	2000	C112_ 66.2 S05 M05B4	111	C112_ 66.2 P63 BN63B4	112
20.2	79	2.5	65.3	5000	C213_ 65.3 S05 M05B4	114	C213_ 65.3 P63 BN63B4	115
20.9	78	1.7	63.3	5000	C212_ 63.3 S05 M05B4	114	C212_ 63.3 P63 BN63B4	115
22.1	74	1.1	59.6	2000	C112_ 59.6 S05 M05B4	111	C112_ 59.6 P63 BN63B4	112
22.4	71	2.7	58.8	5000	C213_ 58.8 S05 M05B4	114	C213_ 58.8 P63 BN63B4	115
23.2	70	1.6	57.0	5000	C212_ 57.0 S05 M05B4	114	C212_ 57.0 P63 BN63B4	115

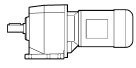

## 0.18 kW



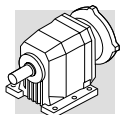

$n_2$ min <sup>-1</sup>	$M_2$ Nm	S	i	$R_{n2}$ N			 IEC	
23.9	68	1.3	55.2	2000	C112_ 55.2 S05 M05B4	111	C112_ 55.2 P63 BN63B4	112
24.1	68	2.3	54.7	5000	C212_ 54.7 S05 M05B4	114	C212_ 54.7 P63 BN63B4	115
26.6	62	1.6	49.7	2000	C112_ 49.7 S05 M05B4	111	C112_ 49.7 P63 BN63B4	112
26.8	61	2.3	49.3	5000	C212_ 49.3 S05 M05B4	114	C212_ 49.3 P63 BN63B4	115
27.7	59	1.5	47.6	2000	C112_ 47.6 S05 M05B4	111	C112_ 47.6 P63 BN63B4	112
31	53	1.9	42.9	2000	C112_ 42.9 S05 M05B4	111	C112_ 42.9 P63 BN63B4	112
33	50	0.9	40.3	850	C052_ 40.3 S05 M05B4	110		
36	45	1.0	36.4	850	C052_ 36.4 S05 M05B4	110		
36	46	2.0	37.0	2000	C112_ 37.0 S05 M05B4	111	C112_ 37.0 P63 BN63B4	112
40	41	1.1	32.8	840	C052_ 32.8 S05 M05B4	110		
40	41	2.4	33.4	2000	C112_ 33.4 S05 M05B4	111	C112_ 33.4 P63 BN63B4	112
45	37	2.5	29.5	2000	C112_ 29.5 S05 M05B4	111	C112_ 29.5 P63 BN63B4	112
49	34	1.3	27.1	820	C052_ 27.1 S05 M05B4	110		
52	31	2.8	25.4	2000	C112_ 25.4 S05 M05B4	111	C112_ 25.4 P63 BN63B4	112
58	28	3.0	22.8	2000	C112_ 22.8 S05 M05B4	111	C112_ 22.8 P63 BN63B4	112
63	26	1.7	21.0	810	C052_ 21.0 S05 M05B4	110		
64	26	3.2	20.6	2000	C112_ 20.6 S05 M05B4	111	C112_ 20.6 P63 BN63B4	112
70	23	1.7	18.9	790	C052_ 18.9 S05 M05B4	110		
71	23	3.4	18.6	2000	C112_ 18.6 S05 M05B4	111	C112_ 18.6 P63 BN63B4	112
77	21	3.6	17.2	2000	C112_ 17.2 S05 M05B4	111	C112_ 17.2 P63 BN63B4	112
85	19	2.1	15.6	760	C052_ 15.6 S05 M05B4	110		
106	15	2.6	12.5	740	C052_ 12.5 S05 M05B4	110		
118	14	2.9	11.2	720	C052_ 11.2 S05 M05B4	110		
142	11	2.6	9.3	690	C052_ 9.3 S05 M05B4	110		
178	9	3.3	7.4	650	C052_ 7.4 S05 M05B4	110		
197	8	3.6	6.7	640	C052_ 6.7 S05 M05B4	110		
223	7	7.2	6.2	1690	C112_ 6.2 S05 M05B4	111	C112_ 6.2 P63 BN63B4	112
223	7	7.3	12.1	1700	C112_ 12.1 S05 M05A2	111	C112_ 12.1 P63 BN63A2	112
240	7	4.4	5.5	600	C052_ 5.5 S05 M05B4	110		
268	6	8.1	10.1	1600	C112_ 10.1 S05 M05A2	111	C112_ 10.1 P63 BN63A2	112
286	6	8.4	4.9	1560	C112_ 4.9 S05 M05B4	111	C112_ 4.9 P63 BN63B4	112
298	5	8.8	9.1	1550	C112_ 9.1 S05 M05A2	111	C112_ 9.1 P63 BN63A2	112
354	5	9.8	7.6	1470	C112_ 7.6 S05 M05A2	111	C112_ 7.6 P63 BN63A2	112
381	4	9.8	3.7	1430	C112_ 3.7 S05 M05B4	111	C112_ 3.7 P63 BN63B4	112
393	4	10.4	6.9	1420	C112_ 6.9 S05 M05A2	111	C112_ 6.9 P63 BN63A2	112
502	3	11.4	2.8	1300	C112_ 2.8 S05 M05B4	111	C112_ 2.8 P63 BN63B4	112
577	3	13.4	4.9	1250	C112_ 4.9 S05 M05A2	111	C112_ 4.9 P63 BN63A2	112
770	2	16.0	3.7	1140	C112_ 3.7 S05 M05A2	111	C112_ 3.7 P63 BN63A2	112
1015	2	18.7	2.8	1040	C112_ 2.8 S05 M05A2	111	C112_ 2.8 P63 BN63A2	112

## 0.25 kW

0.61	3575	1.1	1481	35000			C804_ 1481 P71 BN71B6	136
0.77	2820	1.4	1168	35000			C804_ 1168 P71 BN71B6	136
1.2	1753	0.9	726.3	16000	C614_ 726.3 S1 M1SD6	129	C614_ 726.3 P71 BN71B6	130
1.6	1330	0.8	808.0	10000			C514_ 808.0 P63 BN63C4	127
1.6	1327	0.8	549.7	10000	C514_ 549.7 S1 M1SD6	126	C514_ 549.7 P71 BN71B6	127
1.9	1134	0.9	717.7	10000			C514_ 717.7 P71 BN71A4	127
1.9	1120	0.9	463.9	10000	C514_ 463.9 S1 M1SD6	126	C514_ 463.9 P71 BN71B6	127
2.0	1101	1.5	668.8	16000			C614_ 668.8 P63 BN63C4	130
2.4	894	1.8	370.1	16000	C614_ 370.1 S1 M1SD6	129	C614_ 370.1 P71 BN71B6	130
2.5	869	1.2	549.7	10000			C514_ 549.7 P71 BN71A4	127
2.9	741	0.8	450.2	7000	C414_ 450.2 S05 M05C4	123	C414_ 450.2 P71 BN71A4	124
3.2	689	0.9	418.5	7000	C414_ 418.5 S05 M05C4	123	C414_ 418.5 P71 BN71A4	124
3.2	684	1.5	415.7	10000			C514_ 415.7 P71 BN71A4	127
3.5	628	1.0	381.8	7000	C414_ 381.8 S05 M05C4	123	C414_ 381.8 P71 BN71A4	124
3.5	625	1.6	379.6	10000			C514_ 379.6 P71 BN71A4	127
3.8	567	0.8	344.3	6500	C354_ 344.3 S05 M05C4	120	C354_ 344.3 P71 BN71A4	121
4.0	549	1.1	333.4	7000	C414_ 333.4 S05 M05C4	123	C414_ 333.4 P71 BN71A4	124
4.0	537	1.9	326.1	10000			C514_ 326.1 P71 BN71A4	127
4.1	525	0.9	318.9	6500	C354_ 318.9 S05 M05C4	120	C354_ 318.9 P71 BN71A4	121
4.3	501	1.2	304.2	7000	C414_ 304.2 S05 M05C4	123	C414_ 304.2 P71 BN71A4	124

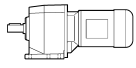



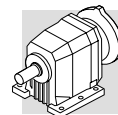

## 0.25 kW

$n_2$ min <sup>-1</sup>	$M_2$ Nm	S	i	$R_{n2}$ N				
4.4	490	2.0	297.8	10000			C514_ 297.8 P71 BN71A4	127
4.5	478	0.9	290.6	6500	C354_ 290.6 S05 M05C4	120	C354_ 290.6 P71 BN71A4	121
5.0	434	2.3	263.8	10000	C414_ 263.0 S05 M05C4	123	C514_ 263.8 P71 BN71A4	127
5.0	433	1.4	263.0	7000	C354_ 255.0 S05 M05C4	120	C414_ 263.0 P71 BN71A4	124
5.2	420	1.1	255.0	6500			C354_ 255.0 P71 BN71A4	121
5.5	395	1.5	239.9	7000	C414_ 239.9 S05 M05C4	123	C414_ 239.9 P71 BN71A4	124
5.7	382	1.2	232.3	6500	C354_ 232.3 S05 M05C4	120	C354_ 232.3 P71 BN71A4	121
6.3	350	2.9	216.7	10000			C513_ 216.7 P71 BN71A4	127
6.7	333	1.4	206.4	6500			C353_ 206.4 P71 BN71A4	121
6.8	326	0.9	194.1	5500	C313_ 194.1 S05 M05C4	117	C313_ 194.1 P71 BN71A4	118
7.2	308	1.9	190.8	7000			C413_ 190.8 P71 BN71A4	124
7.3	304	1.5	188.0	6500			C353_ 188.0 P71 BN71A4	121
7.9	282	1.1	167.5	5500	C313_ 167.5 S05 M05C4	117	C313_ 167.5 P71 BN71A4	118
8.4	265	2.3	164.1	7000			C413_ 164.1 P71 BN71A4	124
8.5	262	1.7	162.0	6500			C353_ 162.0 P71 BN71A4	121
8.9	250	1.2	148.4	5500	C313_ 148.4 S05 M05C4	117	C313_ 148.4 P71 BN71A4	118
9.3	238	1.9	147.6	6500			C353_ 147.6 P71 BN71A4	121
9.7	230	0.9	136.5	5000	C213_ 136.5 S05 M05C4	114	C213_ 136.5 P71 BN71A4	115
9.8	226	2.0	139.8	6500			C353_ 139.8 P71 BN71A4	121
10.3	215	2.8	132.9	7000			C413_ 132.9 P71 BN71A4	124
10.8	206	2.2	127.3	6500			C353_ 127.3 P71 BN71A4	121
10.8	206	1.0	122.2	5000	C213_ 122.2 S05 M05C4	114	C213_ 122.2 P71 BN71A4	115
10.8	206	1.5	122.4	5500	C313_ 122.4 S05 M05C4	117	C313_ 122.4 P71 BN71A4	118
12.0	185	1.1	110.0	5000	C213_ 110.0 S05 M05C4	114	C213_ 110.0 P71 BN71A4	115
12.0	185	1.6	110.2	5500	C313_ 110.2 S05 M05C4	117	C313_ 110.2 P71 BN71A4	118
12.3	180	2.5	111.5	6500			C353_ 111.5 P71 BN71A4	121
12.8	174	1.7	103.3	5500	C313_ 103.3 S05 M05C4	117	C313_ 103.3 P71 BN71A4	118
13.2	168	1.2	100.2	5000	C213_ 100.2 S05 M05C4	114	C213_ 100.2 P71 BN71A4	115
13.5	164	2.7	101.6	6500			C353_ 101.6 P71 BN71A4	121
14.2	156	1.9	93.0	5500	C313_ 93.0 S05 M05C4	117	C313_ 93.0 P71 BN71A4	118
14.6	152	1.3	90.2	5000	C213_ 90.2 S05 M05C4	114	C213_ 90.2 P71 BN71A4	115
15.0	148	3.0	91.9	6500			C353_ 91.9 P71 BN71A4	121
16.0	139	1.4	82.6	5000	C213_ 82.6 S05 M05C4	114	C213_ 82.6 P71 BN71A4	115
16.0	139	2.2	82.6	5500	C313_ 82.6 S05 M05C4	117	C313_ 82.6 P71 BN71A4	118
17.8	125	1.6	74.4	5000	C213_ 74.4 S05 M05C4	114	C213_ 74.4 P71 BN71A4	115
17.8	125	2.4	74.3	5500	C313_ 74.3 S05 M05C4	117	C313_ 74.3 P71 BN71A4	118
20.0	114	0.8	66.2	2000	C112_ 66.2 S05 M05C4	111	C112_ 66.2 P71 BN71A4	112
20.2	110	1.8	65.3	5000	C213_ 65.3 S05 M05C4	114	C213_ 65.3 P71 BN71A4	115
20.9	109	1.2	63.3	5000	C212_ 63.3 S05 M05C4	114	C212_ 63.3 P71 BN71A4	115
22.1	102	0.8	59.6	2000	C112_ 59.6 S05 M05C4	111	C112_ 59.6 P71 BN71A4	112
22.4	99	1.9	58.8	5000	C213_ 58.8 S05 M05C4	114	C213_ 58.8 P71 BN71A4	115
23.2	98	1.2	57.0	5000	C212_ 57.0 S05 M05C4	114	C212_ 57.0 P71 BN71A4	115
23.9	95	0.9	55.2	2000	C112_ 55.2 S05 M05C4	111	C112_ 55.2 P71 BN71A4	112
24.1	94	1.6	54.7	5000	C212_ 54.7 S05 M05C4	114	C212_ 54.7 P71 BN71A4	115
26.6	85	1.2	49.7	2000	C112_ 49.7 S05 M05C4	111	C112_ 49.7 P71 BN71A4	112
26.8	85	1.7	49.3	4910	C212_ 49.3 S05 M05C4	114	C212_ 49.3 P71 BN71A4	115
27.7	82	1.1	47.6	2000	C112_ 47.6 S05 M05C4	111	C112_ 47.6 P71 BN71A4	112
31	74	1.4	42.9	2000	C112_ 42.9 S05 M05C4	111	C112_ 42.9 P71 BN71A4	112
31	74	2.6	43.3	4750	C212_ 43.3 S05 M05C4	114	C212_ 43.3 P71 BN71A4	115
36	64	1.4	37.0	2000	C112_ 37.0 S05 M05C4	111	C112_ 37.0 P71 BN71A4	112
36	63	3.2	36.8	4540	C212_ 36.8 S05 M05C4	114	C212_ 36.8 P71 BN71A4	115
45	51	1.8	29.5	2000	C112_ 29.5 S05 M05C4	111	C112_ 29.5 P71 BN71A4	112
49	47	1.0	27.1	700	C052_ 27.1 S05 M05C4	110		
52	44	2.0	25.4	2000	C112_ 25.4 S05 M05C4	111	C112_ 25.4 P71 BN71A4	112
58	39	2.2	22.8	2000	C112_ 22.8 S05 M05C4	111	C112_ 22.8 P71 BN71A4	112
63	36	1.2	21.0	720	C052_ 21.0 S05 M05C4	110		
64	35	2.3	20.6	2000	C112_ 20.6 S05 M05C4	111	C112_ 20.6 P71 BN71A4	112
70	33	1.2	18.9	710	C052_ 18.9 S05 M05C4	110		
71	32	2.5	18.6	2000	C112_ 18.6 S05 M05C4	111	C112_ 18.6 P71 BN71A4	112
77	29	2.6	17.2	2000	C112_ 17.2 S05 M05C4	111	C112_ 17.2 P71 BN71A4	112
85	27	1.5	15.6	700	C052_ 15.6 S05 M05C4	110		
85	27	2.8	15.5	2000	C112_ 15.5 S05 M05C4	111	C112_ 15.5 P71 BN71A4	112
98	23	3.0	13.4	2000	C112_ 13.4 S05 M05C4	111	C112_ 13.4 P71 BN71A4	112
106	22	1.9	12.5	690	C052_ 12.5 S05 M05C4	110		
109	21	3.2	12.1	2000	C112_ 12.1 S05 M05C4	111	C112_ 12.1 P71 BN71A4	112
118	19	2.1	11.2	670	C052_ 11.2 S05 M05C4	110		

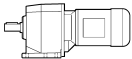

## 0.25 kW

$n_2$ min <sup>-1</sup>	$M_2$ Nm	S	i	$R_{n2}$ N				
131	17	3.6	10.1	1980	C112_ 10.1 S05 M05C4	111	C112_ 10.1 P71 BN71A4	112
142	16	1.9	9.3	650	C052_ 9.3 S05 M05C4	110		
157	14	4.2	17.2	1870	C112_ 17.2 S05 M05B2	111	C112_ 17.2 P63 BN63B2	112
178	13	2.4	7.4	620	C052_ 7.4 S05 M05C4	110		
197	12	2.6	6.7	610	C052_ 6.7 S05 M05C4	110		
221	10	5.2	6.2	1680	C112_ 6.2 S05 M05C4	111	C112_ 6.2 P71 BN71A4	112
223	10	5.2	12.1	1680	C112_ 12.1 S05 M05B2	111	C112_ 12.1 P63 BN63B2	112
240	9	3.2	5.5	580	C052_ 5.5 S05 M05C4	110		
268	8	5.8	10.1	1590	C112_ 10.1 S05 M05B2	111	C112_ 10.1 P63 BN63B2	112
282	8	6.0	4.9	1550	C112_ 4.9 S05 M05C4	111	C112_ 4.9 P71 BN71A4	112
298	8	6.3	9.1	1540	C112_ 9.1 S05 M05B2	111	C112_ 9.1 P63 BN63B2	112
354	6	7.0	7.6	1460	C112_ 7.6 S05 M05B2	111	C112_ 7.6 P63 BN63B2	112
377	6	7.0	3.7	1420	C112_ 3.7 S05 M05C4	111	C112_ 3.7 P71 BN71A4	112
393	6	7.5	6.9	1410	C112_ 6.9 S05 M05B2	111	C112_ 6.9 P63 BN63B2	112
497	5	8.1	2.8	1300	C112_ 2.8 S05 M05C4	111	C112_ 2.8 P71 BN71A4	112
577	4	9.7	4.9	1240	C112_ 4.9 S05 M05B2	111	C112_ 4.9 P63 BN63B2	112
770	3	11.5	3.7	1130	C112_ 3.7 S05 M05B2	111	C112_ 3.7 P63 BN63B2	112



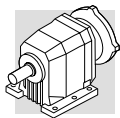

## 0.37 kW

0.73	4382	1.6	1240	60000	C904_ 1240 S1 M1LA6	138	C904_ 1240 P80 BN80A6	139
0.78	4127	1.0	1168	35000			C804_ 1168 P80 BN80A6	136
0.93	3476	1.2	1481	35000			C804_ 1481 P71 BN71B4	136
1.2	2741	1.5	1168	35000			C804_ 1168 P71 BN71B4	136
1.4	2220	1.8	945.7	35000			C804_ 945.7 P71 BN71B4	136
1.5	2165	1.1	922.6	25000			C704_ 922.6 P71 BN71B4	133
1.7	1869	0.9	796.1	16000	C614_ 796.1 S1 M1SD4	129	C614_ 796.1 P71 BN71B4	130
2.0	1570	1.0	668.8	16000	C614_ 668.8 S1 M1SD4	129	C614_ 668.8 P71 BN71B4	130
2.1	1543	1.5	657.3	25000			C704_ 657.3 P71 BN71B4	133
2.4	1341	1.2	571.2	16000	C614_ 571.2 S1 M1SD4	129	C614_ 571.2 P71 BN71B4	130
2.5	1302	1.8	554.7	25000			C704_ 554.7 P71 BN71B4	133
2.5	1290	0.8	549.7	10000	C514_ 549.7 S1 M1SD4	126	C514_ 549.7 P71 BN71B4	127
2.6	1223	1.3	521.1	16000	C614_ 521.1 S1 M1SD4	129	C614_ 521.1 P71 BN71B4	130
3.3	989	1.6	421.5	16000	C614_ 421.5 S1 M1SD4	129	C614_ 421.5 P71 BN71B4	130
3.3	976	1.0	415.7	10000	C514_ 415.7 S1 M1SD4	126	C514_ 415.7 P71 BN71B4	127
3.3	961	2.4	409.4	25000			C704_ 409.4 P71 BN71B4	133
3.6	891	1.1	379.6	10000	C514_ 379.6 S1 M1SD4	126	C514_ 379.6 P71 BN71B4	127
3.7	869	1.8	370.1	16000	C614_ 370.1 S1 M1SD4	129	C614_ 370.1 P71 BN71B4	130
4.1	793	2.0	337.7	16000	C614_ 337.7 S1 M1SD4	129	C614_ 337.7 P71 BN71B4	130
4.1	783	0.8	333.4	7000	C414_ 333.4 S1 M1SD4	123	C414_ 333.4 P71 BN71B4	124
4.2	765	1.3	326.1	10000	C514_ 326.1 S1 M1SD4	126	C514_ 326.1 P71 BN71B4	127
4.6	699	1.4	297.8	10000	C514_ 297.8 S1 M1SD4	126	C514_ 297.8 P71 BN71B4	127
5.2	619	1.6	263.8	10000	C514_ 263.8 S1 M1SD4	126	C514_ 263.8 P71 BN71B4	127
5.2	617	1.0	263.0	7000	C414_ 263.0 S1 M1SD4	123	C414_ 263.0 P71 BN71B4	124
5.4	599	0.8	255.0	6500	C354_ 255.0 S1 M1SD4	120	C354_ 255.0 P71 BN71B4	121
5.9	545	0.8	232.3	6500	C354_ 232.3 S1 M1SD4	120	C354_ 232.3 P71 BN71B4	121
6.3	520	1.9	216.7	10000	C513_ 216.7 S1 M1SD4	126	C513_ 216.7 P71 BN71B4	127
6.6	502	1.2	209.1	7000	C413_ 209.1 S1 M1SD4	123	C413_ 209.1 P71 BN71B4	124
6.6	495	0.9	206.4	6500	C353_ 206.4 S1 M1SD4	120	C353_ 206.4 P71 BN71B4	121
6.9	475	2.1	197.9	10000	C513_ 197.9 S1 M1SD4	126	C513_ 197.9 P71 BN71B4	127
7.2	458	1.3	190.8	7000	C413_ 190.8 S1 M1SD4	123	C413_ 190.8 P71 BN71B4	124
7.3	451	1.0	188.0	6500	C353_ 188.0 S1 M1SD4	120	C353_ 188.0 P71 BN71B4	121
7.6	431	1.4	179.9	7000	C413_ 179.9 S1 M1SD4	123	C413_ 179.9 P71 BN71B4	124
7.8	422	2.4	175.8	10000	C513_ 175.8 S1 M1SD4	126	C513_ 175.8 P71 BN71B4	127
8.3	394	1.5	164.1	7000	C413_ 164.1 S1 M1SD4	123	C413_ 164.1 P71 BN71B4	124
8.5	389	1.2	162.0	6500	C353_ 162.0 S1 M1SD4	120	C353_ 162.0 P71 BN71B4	121
8.5	385	2.6	160.5	10000	C513_ 160.5 S1 M1SD4	126	C513_ 160.5 P71 BN71B4	127
9.3	354	1.3	147.6	6500	C353_ 147.6 S1 M1SD4	120	C353_ 147.6 P71 BN71B4	121
9.4	349	1.7	145.6	7000	C413_ 145.6 S1 M1SD4	123	C413_ 145.6 P71 BN71B4	124
9.8	335	1.3	139.8	6500	C353_ 139.8 S1 M1SD4	120	C353_ 139.8 P71 BN71B4	121
10.3	320	0.9	133.6	5500	C313_ 133.6 S1 M1SD4	117	C313_ 133.6 P71 BN71B4	118
10.3	319	1.9	132.9	7000	C413_ 132.9 S1 M1SD4	123	C413_ 132.9 P71 BN71B4	124
11.2	293	1.0	122.4	5500	C313_ 122.4 S1 M1SD4	117	C313_ 122.4 P71 BN71B4	118



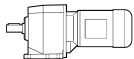



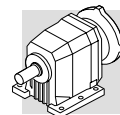

## 0.37 kW

$n_2$ min <sup>-1</sup>	$M_2$ Nm	S	i	$R_{n2}$ N				
11.4	289	2.1	120.6	7000	C413_ 120.6 S1 M1SD4	123	C413_ 120.6 P71 BN71B4	124
12.4	264	1.1	110.2	5500	C313_ 110.2 S1 M1SD4	117	C313_ 110.2 P71 BN71B4	118
12.4	264	2.3	110.1	7000	C413_ 110.1 S1 M1SD4	123	C413_ 110.1 P71 BN71B4	124
13.3	248	1.2	103.3	5500	C313_ 103.3 S1 M1SD4	117	C313_ 103.3 P71 BN71B4	118
13.4	245	2.4	102.3	7000	C413_ 102.3 S1 M1SD4	123	C413_ 102.3 P71 BN71B4	124
14.7	224	2.7	93.3	7000	C413_ 93.3 S1 M1SD4	123	C413_ 93.3 P71 BN71B4	124
14.7	223	1.3	93.0	5500	C313_ 93.0 S1 M1SD4	117	C313_ 93.0 P71 BN71B4	118
15.2	216	0.9	90.2	5000	C213_ 90.2 S1 M1SD4	114	C213_ 90.2 P71 BN71B4	115
16.6	198	1.0	82.6	5000	C213_ 82.6 S1 M1SD4	114	C213_ 82.6 P71 BN71B4	115
16.6	198	1.5	82.6	5500	C313_ 82.6 S1 M1SD4	117	C313_ 82.6 P71 BN71B4	118
16.8	196	3.1	81.5	7000	C413_ 81.5 S1 M1SD4	123	C413_ 81.5 P71 BN71B4	124
18.4	178	1.1	74.4	5000	C213_ 74.4 S1 M1SD4	114	C213_ 74.4 P71 BN71B4	115
18.4	178	1.7	74.3	5500	C313_ 74.3 S1 M1SD4	117	C313_ 74.3 P71 BN71B4	118
18.4	178	3.4	74.4	7000	C413_ 74.4 S1 M1SD4	123	C413_ 74.4 P71 BN71B4	124
20.5	164	1.3	66.8	5500	C312_ 66.8 S1 M1SD4	117	C312_ 66.8 P71 BN71B4	118
21.0	157	1.3	65.3	5000	C213_ 65.3 S1 M1SD4	114	C213_ 65.3 P71 BN71B4	115
22.1	149	3.0	62.0	6500	C353_ 62.0 S1 M1SD4	120	C353_ 62.0 P71 BN71B4	121
23.3	141	1.3	58.8	4880	C213_ 58.8 S1 M1SD4	114	C213_ 58.8 P71 BN71B4	115
26.1	128	2.3	52.4	5500	C312_ 52.4 S1 M1SD4	117	C312_ 52.4 P71 BN71B4	118
27.6	122	0.8	49.7	2000	C112_ 49.7 S1 M1SD4	111	C112_ 49.7 P71 BN71B4	112
27.8	121	1.2	49.3	4660	C212_ 49.3 S1 M1SD4	114	C212_ 49.3 P71 BN71B4	115
29.0	116	2.6	47.2	5500	C312_ 47.2 S1 M1SD4	117	C312_ 47.2 P71 BN71B4	118
32	105	1.0	42.9	2000	C112_ 42.9 S1 M1SD4	111	C112_ 42.9 P71 BN71B4	112
32	106	1.8	43.3	4530	C212_ 43.3 S1 M1SD4	114	C212_ 43.3 P71 BN71B4	115
34	100	3.0	40.7	5500	C312_ 40.7 S1 M1SD4	117	C312_ 40.7 P71 BN71B4	118
35	95	1.8	39.0	4410	C212_ 39.0 S1 M1SD4	114	C212_ 39.0 P71 BN71B4	115
37	91	1.0	37.0	2000	C112_ 37.0 S1 M1SD4	111	C112_ 37.0 P71 BN71B4	112
37	90	2.2	36.8	4360	C212_ 36.8 S1 M1SD4	114	C212_ 36.8 P71 BN71B4	115
38	88	3.4	36.1	5500	C312_ 36.1 S1 M1SD4	117	C312_ 36.1 P71 BN71B4	118
41	82	1.2	33.4	2000	C112_ 33.4 S1 M1SD4	111	C112_ 33.4 P71 BN71B4	112
41	81	2.5	33.1	4240	C212_ 33.1 S1 M1SD4	114	C212_ 33.1 P71 BN71B4	115
42	80	1.1	32.8	2000	C112_ 32.8 S1 M1SD4	111	C112_ 32.8 P71 BN71B4	112
46	72	1.3	29.5	2000	C112_ 29.5 S1 M1SD4	111	C112_ 29.5 P71 BN71B4	112
46	73	2.8	29.6	4130	C212_ 29.6 S1 M1SD4	114	C212_ 29.6 P71 BN71B4	115
51	65	3.1	26.7	4010	C212_ 26.7 S1 M1SD4	114	C212_ 26.7 P71 BN71B4	115
54	62	1.4	25.4	2000	C112_ 25.4 S1 M1SD4	111	C112_ 25.4 P71 BN71B4	112
56	59	3.4	24.3	3920	C212_ 24.3 S1 M1SD4	114	C212_ 24.3 P71 BN71B4	115
60	56	1.5	22.8	2000	C112_ 22.8 S1 M1SD4	111	C112_ 22.8 P71 BN71B4	112
66	51	1.6	20.6	2000	C112_ 20.6 S1 M1SD4	111	C112_ 20.6 P71 BN71B4	112
74	46	1.7	18.6	2000	C112_ 18.6 S1 M1SD4	111	C112_ 18.6 P71 BN71B4	112
80	42	1.8	17.2	2000	C112_ 17.2 S1 M1SD4	111	C112_ 17.2 P71 BN71B4	112
88	39	1.0	15.6	580	C052_ 15.6 S1 M1SD4	110		
89	38	2.0	15.5	2000	C112_ 15.5 S1 M1SD4	111	C112_ 15.5 P71 BN71B4	112
102	33	2.1	13.4	2000	C112_ 13.4 S1 M1SD4	111	C112_ 13.4 P71 BN71B4	112
110	31	1.3	12.5	600	C052_ 12.5 S1 M1SD4	110		
113	30	2.3	12.1	2000	C112_ 12.1 S1 M1SD4	111	C112_ 12.1 P71 BN71B4	112
122	28	1.4	11.2	590	C052_ 11.2 S1 M1SD4	110		
136	25	2.6	10.1	1930	C112_ 10.1 S1 M1SD4	111	C112_ 10.1 P71 BN71B4	112
147	23	1.3	9.3	580	C052_ 9.3 S1 M1SD4	110		
151	22	2.7	9.1	1870	C112_ 9.1 S1 M1SD4	111	C112_ 9.1 P71 BN71B4	112
164	20	2.2	5.5	570	C052_ 5.5 S1 M1LA6	110		
180	19	3.0	7.6	1780	C112_ 7.6 S1 M1SD4	111	C112_ 7.6 P71 BN71B4	112
185	18	1.6	7.4	570	C052_ 7.4 S1 M1SD4	110		
199	17	3.2	6.9	1730	C112_ 6.9 S1 M1SD4	111	C112_ 6.9 P71 BN71B4	112
204	17	1.8	6.7	560	C052_ 6.7 S1 M1SD4	110		
220	15	3.5	6.2	1650	C112_ 6.2 S1 M1SD4	111	C112_ 6.2 P71 BN71B4	112
228	15	3.6	12.1	1650	C112_ 12.1 S05 M05C2	111	C112_ 12.1 P71 BN71A2	112
249	14	2.2	5.5	540	C052_ 5.5 S1 M1SD4	110		
273	12	4.0	10.1	1570	C112_ 10.1 S05 M05C2	111	C112_ 10.1 P71 BN71A2	112
281	12	4.0	4.9	1530	C112_ 4.9 S1 M1SD4	111	C112_ 4.9 P71 BN71B4	112
303	11	4.3	9.1	1520	C112_ 9.1 S05 M05C2	111	C112_ 9.1 P71 BN71A2	112
361	9	4.8	7.6	1440	C112_ 7.6 S05 M05C2	111	C112_ 7.6 P71 BN71A2	112
375	9	4.7	3.7	1400	C112_ 3.7 S1 M1SD4	111	C112_ 3.7 P71 BN71B4	112
400	8	5.1	6.9	1390	C112_ 6.9 S05 M05C2	111	C112_ 6.9 P71 BN71A2	112
495	7	5.5	2.8	1290	C112_ 2.8 S1 M1SD4	111	C112_ 2.8 P71 BN71B4	112
577	6	6.5	4.9	1230	C112_ 4.9 S05 M05C2	111	C112_ 4.9 P71 BN71A2	112
770	4	7.8	3.7	1120	C112_ 3.7 S05 M05C2	111	C112_ 3.7 P71 BN71A2	112
1015	3	9.1	2.8	1030	C112_ 2.8 S05 M05C2	111	C112_ 2.8 P71 BN71A2	112

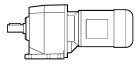



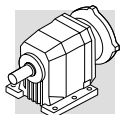

## 0.55 kW

$n_2$ min <sup>-1</sup>	$M_2$ Nm	S	i	$R_{n2}$ N				
0.74	6442	1.1	1240	60000	C904_ 1240 S2 M2SA6	138	C904_ 1240 P80 BN80B6	139
0.85	5616	2.1	1081	85000	C1004_ 1081 S2 M2SA6	141	C1004_ 1081 P80 BN80B6	142
1.0	4792	1.5	922.3	60000	C904_ 922.3 S2 M2SA6	138	C904_ 922.3 P80 BN80B6	139
1.1	4381	0.9	1274	35000	C804_ 1274 S1 M1LA4	135	C804_ 1274 P80 BN80A4	136
1.1	4295	1.7	1240	60000	C904_ 1240 S1 M1LA4	138	C904_ 1240 P80 BN80A4	139
1.3	3549	1.1	1032	35000	C804_ 1032 S1 M1LA4	135	C804_ 1032 P80 BN80A4	136
1.4	3484	2.1	1006	60000	C904_ 1006 S1 M1LA4	138	C904_ 1006 P80 BN80A4	139
1.6	2939	1.4	854.6	35000	C804_ 854.6 S1 M1LA4	135	C804_ 854.6 P80 BN80A4	136
1.6	2923	2.5	844.0	65000	C904_ 844.0 S1 M1LA4	138	C904_ 844.0 P80 BN80A4	139
1.9	2531	0.9	736.0	25000	C704_ 736.0 S1 M1LA4	132	C704_ 736.0 P80 BN80A4	133
1.9	2492	1.6	724.7	35000	C804_ 724.7 S1 M1LA4	135	C804_ 724.7 P80 BN80A4	136
2.1	2284	1.8	664.3	35000	C804_ 664.3 S1 M1LA4	135	C804_ 664.3 P80 BN80A4	136
2.1	2260	1.0	657.3	25000	C704_ 657.3 S1 M1LA4	132	C704_ 657.3 P80 BN80A4	133
2.4	1978	0.8	571.2	16000	C614_ 571.2 S1 M1LA4	129	C614_ 571.2 P80 BN80A4	130
2.5	1907	1.2	554.7	25000	C704_ 554.7 S1 M1LA4	132	C704_ 554.7 P80 BN80A4	133
2.6	1820	2.2	529.3	35000	C804_ 529.3 S1 M1LA4	135	C804_ 529.3 P80 BN80A4	136
3.0	1600	1.0	462.0	16000	C614_ 462.0 S1 M1LA4	129	C614_ 462.0 P80 BN80A4	130
3.1	1566	2.6	455.4	35000	C804_ 455.4 S1 M1LA4	135	C804_ 455.4 P80 BN80A4	136
3.1	1525	1.5	443.5	25000	C704_ 443.5 S1 M1LA4	132	C704_ 443.5 P80 BN80A4	133
3.3	1460	1.1	421.5	16000	C614_ 421.5 S1 M1LA4	129	C614_ 421.5 P80 BN80A4	130
3.6	1315	0.8	379.6	10000	C514_ 379.6 S1 M1LA4	126	C514_ 379.6 P80 BN80A4	127
3.7	1282	1.2	370.1	16000	C614_ 370.1 S1 M1LA4	129	C614_ 370.1 P80 BN80A4	130
3.8	1254	3.2	364.7	35000	C804_ 364.7 S1 M1LA4	135	C804_ 364.7 P80 BN80A4	136
4.0	1184	1.9	344.3	25000	C704_ 344.3 S1 M1LA4	132	C704_ 344.3 P80 BN80A4	133
4.1	1170	1.4	337.7	16000	C614_ 337.7 S1 M1LA4	129	C614_ 337.7 P80 BN80A4	130
4.2	1130	0.9	326.1	10000	C514_ 326.1 S1 M1LA4	126	C514_ 326.1 P80 BN80A4	127
4.6	1031	1.0	297.8	10000	C514_ 297.8 S1 M1LA4	126	C514_ 297.8 P80 BN80A4	127
5.0	953	1.7	275.3	16000	C614_ 275.3 S1 M1LA4	129	C614_ 275.3 P80 BN80A4	130
5.1	936	2.5	272.2	25000	C704_ 272.2 S1 M1LA4	132	C704_ 272.2 P80 BN80A4	133
5.2	914	1.1	263.8	10000	C514_ 263.8 S1 M1LA4	126	C514_ 263.8 P80 BN80A4	127
5.7	834	1.2	240.9	10000	C514_ 240.9 S1 M1LA4	126	C514_ 240.9 P80 BN80A4	127
5.8	847	2.7	239.3	25000	C703_ 239.3 S1 M1LA4	132	C703_ 239.3 P80 BN80A4	133
5.8	825	1.9	238.3	16000	C614_ 238.3 S1 M1LA4	129	C614_ 238.3 P80 BN80A4	130
6.2	782	2.9	220.9	25000	C703_ 220.9 S1 M1LA4	132	C703_ 220.9 P80 BN80A4	133
6.3	753	2.1	217.4	16000	C614_ 217.4 S1 M1LA4	129	C614_ 217.4 P80 BN80A4	130
6.4	767	1.3	216.7	10000	C513_ 216.7 S1 M1LA4	126	C513_ 216.7 P80 BN80A4	127
7.0	700	1.4	197.9	10000	C513_ 197.9 S1 M1LA4	126	C513_ 197.9 P80 BN80A4	127
7.0	693	2.3	195.8	16000	C613_ 195.8 S1 M1LA4	129	C613_ 195.8 P80 BN80A4	130
7.1	687	3.3	194.1	25000	C703_ 194.1 S1 M1LA4	132	C703_ 194.1 P80 BN80A4	133
7.7	637	0.9	179.9	7000	C413_ 179.9 S1 M1LA4	123	C413_ 179.9 P80 BN80A4	124
7.7	632	2.5	178.6	16000	C613_ 178.6 S1 M1LA4	129	C613_ 178.6 P80 BN80A4	130
7.9	622	1.6	175.8	10000	C513_ 175.8 S1 M1LA4	126	C513_ 175.8 P80 BN80A4	127
8.4	582	2.7	164.5	16000	C613_ 164.5 S1 M1LA4	129	C613_ 164.5 P80 BN80A4	130
8.4	581	1.0	164.1	7000	C413_ 164.1 S1 M1LA4	123	C413_ 164.1 P80 BN80A4	124
8.6	568	1.8	160.5	10000	C513_ 160.5 S1 M1LA4	126	C513_ 160.5 P80 BN80A4	127
9.2	531	3.0	150.0	16000	C613_ 150.0 S1 M1LA4	129	C613_ 150.0 P80 BN80A4	130
9.4	522	1.9	147.4	10000	C513_ 147.4 S1 M1LA4	126	C513_ 147.4 P80 BN80A4	127
9.5	516	1.2	145.6	7000	C413_ 145.6 S1 M1LA4	123	C413_ 145.6 P80 BN80A4	124
9.8	497	3.2	140.5	16000	C613_ 140.5 S1 M1LA4	129	C613_ 140.5 P80 BN80A4	130
9.9	495	0.9	139.8	6500	C353_ 139.8 S1 M1LA4	120	C353_ 139.8 P80 BN80A4	121
10.3	477	2.1	134.6	10000	C513_ 134.6 S1 M1LA4	126	C513_ 134.6 P80 BN80A4	127
10.4	470	1.3	132.9	7000	C413_ 132.9 S1 M1LA4	123	C413_ 132.9 P80 BN80A4	124
10.8	451	1.0	127.3	6500	C353_ 127.3 S1 M1LA4	120	C353_ 127.3 P80 BN80A4	121
11.1	440	2.3	124.4	10000	C513_ 124.4 S1 M1LA4	126	C513_ 124.4 P80 BN80A4	127
11.4	427	1.4	120.6	7000	C413_ 120.6 S1 M1LA4	123	C413_ 120.6 P80 BN80A4	124
12.1	402	2.5	113.6	10000	C513_ 113.6 S1 M1LA4	126	C513_ 113.6 P80 BN80A4	127
12.4	395	1.1	111.5	6500	C353_ 111.5 S1 M1LA4	120	C353_ 111.5 P80 BN80A4	121
12.5	390	1.5	110.1	7000	C413_ 110.1 S1 M1LA4	123	C413_ 110.1 P80 BN80A4	124
13.5	362	1.7	102.3	7000	C413_ 102.3 S1 M1LA4	123	C413_ 102.3 P80 BN80A4	124
13.6	360	2.8	101.8	10000	C513_ 101.8 S1 M1LA4	126	C513_ 101.8 P80 BN80A4	127
13.6	360	1.3	101.6	6500	C353_ 101.6 S1 M1LA4	120	C353_ 101.6 P80 BN80A4	121
14.8	330	1.8	93.3	7000	C413_ 93.3 S1 M1LA4	123	C413_ 93.3 P80 BN80A4	124
14.8	329	0.9	93.0	5500	C313_ 93.0 S1 M1LA4	117	C313_ 93.0 P80 BN80A4	118
14.8	329	3.0	93.0	10000	C513_ 93.0 S1 M1LA4	126	C513_ 93.0 P80 BN80A4	127
15.0	325	1.4	91.9	6500	C353_ 91.9 S1 M1LA4	120	C353_ 91.9 P80 BN80A4	121
16.5	296	1.5	83.8	6500	C353_ 83.8 S1 M1LA4	120	C353_ 83.8 P80 BN80A4	121
16.7	292	1.0	82.6	5500	C313_ 82.6 S1 M1LA4	117	C313_ 82.6 P80 BN80A4	118
16.9	289	2.1	81.5	7000	C413_ 81.5 S1 M1LA4	123	C413_ 81.5 P80 BN80A4	124
17.5	284	1.1	52.4	5500	C312_ 52.4 S2 M2SA6	117	C312_ 52.4 P80 BN80B6	118
17.8	275	1.6	77.6	6500	C353_ 77.6 S1 M1LA4	120	C353_ 77.6 P80 BN80A4	121

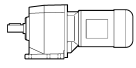



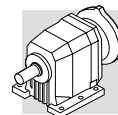

## 0.55 kW

$n_2$ min <sup>-1</sup>	$M_2$ Nm	S	i	$R_{n2}$ N				
18.6	263	2.3	74.4	7000	C413_ 74.4 S1 M1LA4	123	C413_ 74.4 P80 BN80A4	124
18.6	263	1.1	74.3	5500	C313_ 74.3 S1 M1LA4	117	C313_ 74.3 P80 BN80A4	118
19.5	256	1.2	47.2	5500	C312_ 47.2 S2 M2SA6	117	C312_ 47.2 P80 BN80B6	118
19.5	250	1.8	70.7	6500	C353_ 70.7 S1 M1LA4	120	C353_ 70.7 P80 BN80A4	121
21.5	228	2.6	64.3	7000	C413_ 64.3 S1 M1LA4	123	C413_ 64.3 P80 BN80A4	124
22.2	220	2.0	62.0	6500	C353_ 62.0 S1 M1LA4	120	C353_ 62.0 P80 BN80A4	121
22.6	221	1.4	40.7	5500	C312_ 40.7 S2 M2SA6	117	C312_ 40.7 P80 BN80B6	118
23.5	208	0.9	58.8	4420	C213_ 58.8 S1 M1LA4	114	C213_ 58.8 P80 BN80A4	115
23.5	208	2.9	58.7	7000	C413_ 58.7 S1 M1LA4	123	C413_ 58.7 P80 BN80A4	124
24.4	200	2.2	56.5	6500	C353_ 56.5 S1 M1LA4	120	C353_ 56.5 P80 BN80A4	121
26.3	190	1.6	52.4	5500	C312_ 52.4 S1 M1LA4	117	C312_ 52.4 P80 BN80A4	118
26.8	182	3.3	51.5	7000	C413_ 51.5 S1 M1LA4	123	C413_ 51.5 P80 BN80A4	124
27.8	180	1.1	33.1	4270	C212_ 33.1 S2 M2SA6	114	C212_ 33.1 P80 BN80B6	115
28.7	170	2.6	48.2	6500	C353_ 48.2 S1 M1LA4	120	C353_ 48.2 P80 BN80A4	121
29.2	171	1.8	47.2	5500	C312_ 47.2 S1 M1LA4	117	C312_ 47.2 P80 BN80A4	118
31	162	3.1	44.8	7000	C412_ 44.8 S1 M1LA4	123	C412_ 44.8 P80 BN80A4	124
31	155	2.9	43.9	6500	C353_ 43.9 S1 M1LA4	120	C353_ 43.9 P80 BN80A4	121
32	156	1.2	43.3	4190	C212_ 43.3 S1 M1LA4	114	C212_ 43.3 P80 BN80A4	115
34	147	2.0	40.7	5500	C312_ 40.7 S1 M1LA4	117	C312_ 40.7 P80 BN80A4	118
35	141	1.2	39.0	4100	C212_ 39.0 S1 M1LA4	114	C212_ 39.0 P80 BN80A4	115
36	135	3.3	38.1	6500	C353_ 38.1 S1 M1LA4	120	C353_ 38.1 P80 BN80A4	121
38	133	1.5	36.8	4070	C212_ 36.8 S1 M1LA4	114	C212_ 36.8 P80 BN80A4	115
38	131	2.3	36.1	5500	C312_ 36.1 S1 M1LA4	117	C312_ 36.1 P80 BN80A4	118
41	121	0.8	33.4	1550	C112_ 33.4 S1 M1LA4	111	C112_ 33.4 P80 BN80A4	112
42	118	1.7	33.1	3970	C212_ 33.1 S1 M1LA4	114	C212_ 33.1 P80 BN80A4	115
42	118	2.6	32.5	5500	C312_ 32.5 S1 M1LA4	117	C312_ 32.5 P80 BN80A4	118
46	108	2.8	29.8	5500	C312_ 29.8 S1 M1LA4	117	C312_ 29.8 P80 BN80A4	118
47	107	0.9	29.5	1820	C112_ 29.5 S1 M1LA4	111	C112_ 29.5 P80 BN80A4	112
47	107	1.9	29.6	3890	C212_ 29.6 S1 M1LA4	114	C212_ 29.6 P80 BN80A4	115
52	96	2.1	26.7	3800	C212_ 26.7 S1 M1LA4	114	C212_ 26.7 P80 BN80A4	115
52	97	3.1	26.8	5500	C312_ 26.8 S1 M1LA4	117	C312_ 26.8 P80 BN80A4	118
54	92	1.0	25.4	2000	C112_ 25.4 S1 M1LA4	111	C112_ 25.4 P80 BN80A4	112
55	91	3.3	25.1	5500	C312_ 25.1 S1 M1LA4	117	C312_ 25.1 P80 BN80A4	118
57	88	2.3	24.3	3720	C212_ 24.3 S1 M1LA4	114	C212_ 24.3 P80 BN80A4	115
60	83	1.0	22.8	2000	C112_ 22.8 S1 M1LA4	111	C112_ 22.8 P80 BN80A4	112
63	79	2.5	21.9	3630	C212_ 21.9 S1 M1LA4	114	C212_ 21.9 P80 BN80A4	115
67	75	1.1	20.6	2000	C112_ 20.6 S1 M1LA4	111	C112_ 20.6 P80 BN80A4	112
69	72	2.6	20.0	3560	C212_ 20.0 S1 M1LA4	114	C212_ 20.0 P80 BN80A4	115
74	67	1.2	18.6	2000	C112_ 18.6 S1 M1LA4	111	C112_ 18.6 P80 BN80A4	112
77	65	2.8	18.0	3460	C212_ 18.0 S1 M1LA4	114	C212_ 18.0 P80 BN80A4	115
80	62	1.2	17.2	2000	C112_ 17.2 S1 M1LA4	111	C112_ 17.2 P80 BN80A4	112
87	57	3.1	15.8	3350	C212_ 15.8 S1 M1LA4	114	C212_ 15.8 P80 BN80A4	115
89	56	1.3	15.5	2000	C112_ 15.5 S1 M1LA4	111	C112_ 15.5 P80 BN80A4	112
97	52	3.3	14.3	3260	C212_ 14.3 S1 M1LA4	114	C212_ 14.3 P80 BN80A4	115
103	48	1.4	13.4	1990	C112_ 13.4 S1 M1LA4	111	C112_ 13.4 P80 BN80A4	112
114	44	1.5	12.1	1930	C112_ 12.1 S1 M1LA4	111	C112_ 12.1 P80 BN80A4	112
121	41	1.6	7.6	1910	C112_ 7.6 S2 M2SA6	111	C112_ 7.6 P80 BN80B6	112
123	40	1.0	11.2	480	C052_ 11.2 S1 M1LA4	110		
137	36	1.7	10.1	1850	C112_ 10.1 S1 M1LA4	111	C112_ 10.1 P80 BN80A4	112
151	33	3.3	6.1	2860	C212_ 6.1 S2 M2SA6	114	C212_ 6.1 P80 BN80B6	115
152	33	1.9	9.1	1800	C112_ 9.1 S1 M1LA4	111	C112_ 9.1 P80 BN80A4	112
181	28	2.0	7.6	1720	C112_ 7.6 S1 M1LA4	111	C112_ 7.6 P80 BN80A4	112
186	27	1.1	7.4	460	C052_ 7.4 S1 M1LA4	110		
201	25	2.2	6.9	1670	C112_ 6.9 S1 M1LA4	111	C112_ 6.9 P80 BN80A4	112
206	24	1.2	6.7	450	C052_ 6.7 S1 M1LA4	110		
221	23	2.4	6.2	1590	C112_ 6.2 S1 M1LA4	111	C112_ 6.2 P80 BN80A4	112
233	21	2.5	12.1	1610	C112_ 12.1 S1 M1SD2	111	C112_ 12.1 P71 BN71B2	112
251	20	1.5	5.5	430	C052_ 5.5 S1 M1LA4	110		
279	18	2.7	10.1	1530	C112_ 10.1 S1 M1SD2	111	C112_ 10.1 P71 BN71B2	112
283	18	2.7	4.9	1490	C112_ 4.9 S1 M1LA4	111	C112_ 4.9 P80 BN80A4	112
310	16	3.0	9.1	1480	C112_ 9.1 S1 M1SD2	111	C112_ 9.1 P71 BN71B2	112
369	14	3.3	7.6	1410	C112_ 7.6 S1 M1SD2	111	C112_ 7.6 P71 BN71B2	112
378	13	3.2	3.7	1370	C112_ 3.7 S1 M1LA4	111	C112_ 3.7 P80 BN80A4	112
409	12	3.5	6.9	1370	C112_ 6.9 S1 M1SD2	111	C112_ 6.9 P71 BN71B2	112
451	11	3.8	6.2	1300	C112_ 6.2 S1 M1SD2	111	C112_ 6.2 P71 BN71B2	112
499	10	3.7	2.8	1260	C112_ 2.8 S1 M1LA4	111	C112_ 2.8 P80 BN80A4	112
577	9	4.4	4.9	1210	C112_ 4.9 S1 M1SD2	111	C112_ 4.9 P71 BN71B2	112
770	6	5.2	3.7	1110	C112_ 3.7 S1 M1SD2	111	C112_ 3.7 P71 BN71B2	112

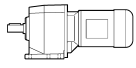



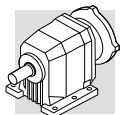

## 0.75 kW

$n_2$ min <sup>-1</sup>	$M_2$ Nm	S	i	$R_{n2}$ N			 IEC	
0.85	7659	1.6	1081	85000	C1004_1081 S2 M2SB6	141	C1004_1081 P90 BN90S6	142
0.91	7127	1.0	1006	60000	C904_1006 S2 M2SB6	138	C904_1006 P90 BN90S6	139
1.1	5773	1.2	1240	35000	C904_1240 S2 M2SA4	138	C904_1240 P80 BN80B4	139
1.5	4403	0.9	945.7	35000	C804_945.7 S2 M2SA4	135	C804_945.7 P80 BN80B4	136
1.5	4294	1.7	922.3	60000	C904_922.3 S2 M2SA4	138	C904_922.3 P80 BN80B4	139
1.8	3647	1.1	783.4	35000	C804_783.4 S2 M2SA4	135	C804_783.4 P80 BN80B4	136
1.8	3602	2.0	773.6	60000	C904_773.6 S2 M2SA4	138	C904_773.6 P80 BN80B4	139
2.1	3093	1.3	664.3	35000	C804_664.3 S2 M2SA4	135	C804_664.3 P80 BN80B4	136
2.1	3039	2.4	652.8	60000	C904_652.8 S2 M2SA4	138	C904_652.8 P80 BN80B4	139
2.6	2487	2.9	534.2	60000	C904_534.2 S2 M2SA4	138	C904_534.2 P80 BN80B4	139
2.6	2464	1.6	529.3	35000	C804_529.3 S2 M2SA4	135	C804_529.3 P80 BN80B4	136
3.1	2128	3.4	457.1	60000	C904_457.1 S2 M2SA4	138	C904_457.1 P80 BN80B4	139
3.1	2120	1.9	455.4	35000	C804_455.4 S2 M2SA4	135	C804_455.4 P80 BN80B4	136
3.2	2065	1.1	443.5	25000	C704_443.5 S2 M2SA4	132	C704_443.5 P80 BN80B4	133
3.3	1962	0.8	421.5	16000	C614_421.5 S2 M2SA4	129	C614_421.5 P80 BN80B4	130
3.4	1906	1.2	409.4	25000	C704_409.4 S2 M2SA4	132	C704_409.4 P80 BN80B4	133
3.8	1723	0.9	370.1	16000	C614_370.1 S2 M2SA4	129	C614_370.1 P80 BN80B4	130
3.8	1733	1.3	239.3	25000	C703_239.3 S2 M2SB6	132	C703_239.3 P90 BN90S6	133
4.1	1572	1.0	337.7	16000	C614_337.7 S2 M2SA4	129	C614_337.7 P80 BN80B4	130
4.3	1563	2.6	215.8	35000	C803_215.8 S2 M2SB6	135	C803_215.8 P90 BN90S6	136
4.4	1480	1.6	317.9	25000	C704_317.9 S2 M2SA4	132	C704_317.9 P80 BN80B4	133
4.6	1405	1.1	301.7	16000	C614_301.7 S2 M2SA4	129	C614_301.7 P80 BN80B4	130
4.7	1417	1.1	195.8	16000	C613_195.8 S2 M2SB6	129	C613_195.8 P90 BN90S6	130
5.1	1282	1.2	275.3	16000	C614_275.3 S2 M2SA4	129	C614_275.3 P80 BN80B4	130
5.1	1267	1.8	272.2	25000	C704_272.2 S2 M2SA4	132	C704_272.2 P80 BN80B4	133
5.2	1293	1.2	178.6	16000	C613_178.6 S2 M2SB6	129	C613_178.6 P90 BN90S6	130
5.3	1228	0.8	263.8	10000	C514_263.8 S2 M2SA4	126	C514_263.8 P80 BN80B4	127
5.6	1191	1.3	164.5	16000	C613_164.5 S2 M2SB6	129	C613_164.5 P90 BN90S6	130
5.8	1121	0.9	240.9	10000	C514_240.9 S2 M2SA4	126	C514_240.9 P80 BN80B4	127
5.8	1139	2.0	239.3	25000	C703_239.3 S2 M2SA4	132	C703_239.3 P80 BN80B4	133
6.3	1051	2.1	220.9	25000	C703_220.9 S2 M2SA4	132	C703_220.9 P80 BN80B4	133
6.4	1012	1.6	217.4	16000	C614_217.4 S2 M2SA4	129	C614_217.4 P80 BN80B4	130
6.5	1031	1.0	216.7	10000	C513_216.7 S2 M2SA4	126	C513_216.7 P80 BN80B4	127
7.1	941	1.1	197.9	10000	C513_197.9 S2 M2SA4	126	C513_197.9 P80 BN80B4	127
7.2	931	1.7	195.8	16000	C613_195.8 S2 M2SA4	129	C613_195.8 P80 BN80B4	130
7.2	924	2.5	194.1	25000	C703_194.1 S2 M2SA4	132	C703_194.1 P80 BN80B4	133
7.8	850	1.9	178.6	16000	C613_178.6 S2 M2SA4	129	C613_178.6 P80 BN80B4	130
8.0	836	1.2	175.8	10000	C513_175.8 S2 M2SA4	126	C513_175.8 P80 BN80B4	127
8.5	782	2.0	164.5	16000	C613_164.5 S2 M2SA4	129	C613_164.5 P80 BN80B4	130
8.6	775	3.0	162.8	25000	C703_162.8 S2 M2SA4	132	C703_162.8 P80 BN80B4	133
8.7	764	1.3	160.5	10000	C513_160.5 S2 M2SA4	126	C513_160.5 P80 BN80B4	127
9.3	714	2.2	150.0	16000	C613_150.0 S2 M2SA4	129	C613_150.0 P80 BN80B4	130
9.5	702	1.4	147.4	10000	C513_147.4 S2 M2SA4	126	C513_147.4 P80 BN80B4	127
10.0	668	2.4	140.5	16000	C613_140.5 S2 M2SA4	129	C613_140.5 P80 BN80B4	130
10.2	654	3.5	137.4	25000	C703_137.4 S2 M2SA4	132	C703_137.4 P80 BN80B4	133
10.4	641	1.6	134.6	10000	C513_134.6 S2 M2SA4	126	C513_134.6 P80 BN80B4	127
10.5	632	0.9	132.9	7000	C413_132.9 S2 M2SA4	123	C413_132.9 P80 BN80B4	124
10.9	610	2.6	128.1	16000	C613_128.1 S2 M2SA4	129	C613_128.1 P80 BN80B4	130
11.3	592	1.7	124.4	10000	C513_124.4 S2 M2SA4	126	C513_124.4 P80 BN80B4	127
11.6	574	1.0	120.6	7000	C413_120.6 S2 M2SA4	123	C413_120.6 P80 BN80B4	124
12.3	541	3.0	113.6	16000	C613_113.6 S2 M2SA4	129	C613_113.6 P80 BN80B4	130
12.3	541	1.9	113.6	10000	C513_113.6 S2 M2SA4	126	C513_113.6 P80 BN80B4	127
12.7	524	1.1	110.1	7000	C413_110.1 S2 M2SA4	123	C413_110.1 P80 BN80B4	124
13.5	493	3.2	103.6	16000	C613_103.6 S2 M2SA4	129	C613_103.6 P80 BN80B4	130
13.7	487	1.2	102.3	7000	C413_102.3 S2 M2SA4	123	C413_102.3 P80 BN80B4	124
13.8	484	2.1	101.8	10000	C513_101.8 S2 M2SA4	126	C513_101.8 P80 BN80B4	127
13.8	483	0.9	101.6	6500	C353_101.6 S2 M2SA4	120	C353_101.6 P80 BN80B4	121
15.0	444	1.4	93.3	7000	C413_93.3 S2 M2SA4	123	C413_93.3 P80 BN80B4	124
15.1	442	2.3	93.0	10000	C513_93.0 S2 M2SA4	126	C513_93.0 P80 BN80B4	127
15.2	437	1.0	91.9	6500	C353_91.9 S2 M2SA4	120	C353_91.9 P80 BN80B4	121
16.7	399	1.1	83.8	6500	C353_83.8 S2 M2SA4	120	C353_83.8 P80 BN80B4	121
17.2	388	1.5	81.5	7000	C413_81.5 S2 M2SA4	123	C413_81.5 P80 BN80B4	124
17.5	380	2.6	79.9	10000	C513_79.9 S2 M2SA4	126	C513_79.9 P80 BN80B4	127
18.0	369	1.2	77.6	6500	C353_77.6 S2 M2SA4	120	C353_77.6 P80 BN80B4	121

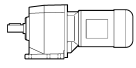



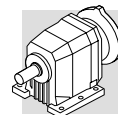

## 0.75 kW

$n_2$ min <sup>-1</sup>	$M_2$ Nm	S	i	$R_{n2}$ N				
18.8	354	1.7	74.4	7000	C413_ 74.4 S2 M2SA4	123	C413_ 74.4 P80 BN80B4	124
19.2	347	2.9	72.9	10000	C513_ 72.9 S2 M2SA4	126	C513_ 72.9 P80 BN80B4	127
19.8	336	1.3	70.7	6500	C353_ 70.7 S2 M2SA4	120	C353_ 70.7 P80 BN80B4	121
21.7	307	3.3	64.6	10000	C513_ 64.6 S2 M2SA4	126	C513_ 64.6 P80 BN80B4	127
21.8	306	2.0	64.3	7000	C413_ 64.3 S2 M2SA4	123	C413_ 64.3 P80 BN80B4	124
22.6	295	1.5	62.0	6500	C353_ 62.0 S2 M2SA4	120	C353_ 62.0 P80 BN80B4	121
22.6	301	1.0	40.7	5500	C312_ 40.7 S2 M2SB6	117	C312_ 40.7 P90 BN90S6	118
23.9	279	2.1	58.7	7000	C413_ 58.7 S2 M2SA4	123	C413_ 58.7 P80 BN80B4	124
24.6	277	2.8	57.0	10000	C512_ 57.0 S2 M2SA4	126	C512_ 57.0 P80 BN80B4	127
24.8	269	1.7	56.5	6500	C353_ 56.5 S2 M2SA4	120	C353_ 56.5 P80 BN80B4	121
26.7	255	1.2	52.4	5500	C312_ 52.4 S2 M2SA4	117	C312_ 52.4 P80 BN80B4	118
27.2	245	2.4	51.5	7000	C413_ 51.5 S2 M2SA4	123	C413_ 51.5 P80 BN80B4	124
27.2	250	2.8	51.4	10000	C512_ 51.4 S2 M2SA4	126	C512_ 51.4 P80 BN80B4	127
29.1	229	2.0	48.2	6500	C353_ 48.2 S2 M2SA4	120	C353_ 48.2 P80 BN80B4	121
29.3	232	3.4	47.8	10000	C512_ 47.8 S2 M2SA4	126	C512_ 47.8 P80 BN80B4	127
29.7	229	1.3	47.2	5500	C312_ 47.2 S2 M2SA4	117	C312_ 47.2 P80 BN80B4	118
29.8	223	2.7	47.0	7000	C413_ 47.0 S2 M2SA4	123	C413_ 47.0 P80 BN80B4	124
31	220	1.4	45.3	5500	C312_ 45.3 S2 M2SA4	117	C312_ 45.3 P80 BN80B4	118
31	218	2.3	44.8	7000	C412_ 44.8 S2 M2SA4	123	C412_ 44.8 P80 BN80B4	124
32	210	0.9	43.3	3810	C212_ 43.3 S2 M2SA4	114	C212_ 43.3 P80 BN80B4	115
34	198	1.5	40.7	5500	C312_ 40.7 S2 M2SA4	117	C312_ 40.7 P80 BN80B4	118
35	192	3.1	40.3	7000	C413_ 40.3 S2 M2SA4	123	C413_ 40.3 P80 BN80B4	124
37	181	2.5	38.1	6500	C353_ 38.1 S2 M2SA4	120	C353_ 38.1 P80 BN80B4	121
38	180	2.8	37.1	7000	C412_ 37.1 S2 M2SA4	123	C412_ 37.1 P80 BN80B4	124
38	179	1.1	36.8	3750	C212_ 36.8 S2 M2SA4	114	C212_ 36.8 P80 BN80B4	115
39	175	1.7	36.1	5500	C312_ 36.1 S2 M2SA4	117	C312_ 36.1 P80 BN80B4	118
42	161	1.2	33.1	3680	C212_ 33.1 S2 M2SA4	114	C212_ 33.1 P80 BN80B4	115
43	158	1.9	32.5	5500	C312_ 32.5 S2 M2SA4	117	C312_ 32.5 P80 BN80B4	118
47	144	1.4	29.6	3630	C212_ 29.6 S2 M2SA4	114	C212_ 29.6 P80 BN80B4	115
47	145	2.1	29.8	5500	C312_ 29.8 S2 M2SA4	117	C312_ 29.8 P80 BN80B4	118
49	137	3.3	28.7	6490	C353_ 28.7 S2 M2SA4	120	C353_ 28.7 P80 BN80B4	121
52	130	1.5	26.7	3560	C212_ 26.7 S2 M2SA4	114	C212_ 26.7 P80 BN80B4	115
52	130	2.3	26.8	5500	C312_ 26.8 S2 M2SA4	117	C312_ 26.8 P80 BN80B4	118
56	122	2.5	25.1	5460	C312_ 25.1 S2 M2SA4	117	C312_ 25.1 P80 BN80B4	118
58	118	1.7	24.3	3510	C212_ 24.3 S2 M2SA4	114	C212_ 24.3 P80 BN80B4	115
62	110	2.7	22.6	5310	C312_ 22.6 S2 M2SA4	117	C312_ 22.6 P80 BN80B4	118
64	106	1.9	21.9	3430	C212_ 21.9 S2 M2SA4	114	C212_ 21.9 P80 BN80B4	115
68	100	0.8	20.6	1450	C112_ 20.6 S2 M2SA4	111	C112_ 20.6 P80 BN80B4	112
70	97	2.0	20.0	3380	C212_ 20.0 S2 M2SA4	114	C212_ 20.0 P80 BN80B4	115
70	98	3.0	20.1	5150	C312_ 20.1 S2 M2SA4	117	C312_ 20.1 P80 BN80B4	118
75	90	0.9	18.6	1580	C112_ 18.6 S2 M2SA4	111	C112_ 18.6 P80 BN80B4	112
77	88	3.2	18.1	5000	C312_ 18.1 S2 M2SA4	117	C312_ 18.1 P80 BN80B4	118
78	88	2.1	18.0	3290	C212_ 18.0 S2 M2SA4	114	C212_ 18.0 P80 BN80B4	115
82	83	0.9	17.2	1750	C112_ 17.2 S2 M2SA4	111	C112_ 17.2 P80 BN80B4	112
88	77	2.3	15.8	3210	C212_ 15.8 S2 M2SA4	114	C212_ 15.8 P80 BN80B4	115
91	75	1.0	15.5	1840	C112_ 15.5 S2 M2SA4	111	C112_ 15.5 P80 BN80B4	112
98	69	2.5	14.3	3120	C212_ 14.3 S2 M2SA4	114	C212_ 14.3 P80 BN80B4	115
104	65	1.1	13.4	1870	C112_ 13.4 S2 M2SA4	111	C112_ 13.4 P80 BN80B4	112
113	60	2.7	12.4	3030	C212_ 12.4 S2 M2SA4	114	C212_ 12.4 P80 BN80B4	115
116	59	1.1	12.1	1830	C112_ 12.1 S2 M2SA4	111	C112_ 12.1 P80 BN80B4	112
125	54	2.9	11.2	2940	C212_ 11.2 S2 M2SA4	114	C212_ 11.2 P80 BN80B4	115
139	49	1.3	10.1	1760	C112_ 10.1 S2 M2SA4	111	C112_ 10.1 P80 BN80B4	112
145	47	3.1	9.6	2840	C212_ 9.6 S2 M2SA4	114	C212_ 9.6 P80 BN80B4	115
154	44	1.4	9.1	1720	C112_ 9.1 S2 M2SA4	111	C112_ 9.1 P80 BN80B4	112
161	42	3.3	8.7	2760	C212_ 8.7 S2 M2SA4	114	C212_ 8.7 P80 BN80B4	115
184	37	1.5	7.6	1650	C112_ 7.6 S2 M2SA4	111	C112_ 7.6 P80 BN80B4	112
204	33	1.6	6.9	1610	C112_ 6.9 S2 M2SA4	111	C112_ 6.9 P80 BN80B4	112
225	30	1.7	6.2	1530	C112_ 6.2 S2 M2SA4	111	C112_ 6.2 P80 BN80B4	112
232	29	1.8	12.1	1560	C112_ 12.1 S1 M1LA2	111	C112_ 12.1 P80 BN80A2	112
278	24	2.0	10.1	1490	C112_ 10.1 S1 M1LA2	111	C112_ 10.1 P80 BN80A2	112
288	24	2.0	4.9	1440	C112_ 4.9 S2 M2SA4	111	C112_ 4.9 P80 BN80B4	112
309	22	2.2	9.1	1450	C112_ 9.1 S1 M1LA2	111	C112_ 9.1 P80 BN80A2	112
332	20	2.1	2.8	1390	C112_ 2.8 S2 M2SB6	111	C112_ 2.8 P90 BN90S6	112
367	19	2.4	7.6	1380	C112_ 7.6 S1 M1LA2	111	C112_ 7.6 P80 BN80A2	112
383	18	2.4	3.7	1330	C112_ 3.7 S2 M2SA4	111	C112_ 3.7 P80 BN80B4	112
408	17	2.6	6.9	1340	C112_ 6.9 S1 M1LA2	111	C112_ 6.9 P80 BN80A2	112

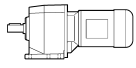

## 0.75 kW



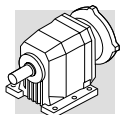

$n_2$ min <sup>-1</sup>	$M_2$ Nm	S	i	$R_{n2}$ N			 IEC	
449	15	2.8	6.2	1280	C112_ 6.2 S1 M1LA2	111	C112_ 6.2 P80 BN80A2	112
506	13	2.8	2.8	1230	C112_ 2.8 S2 M2SA4	111	C112_ 2.8 P80 BN80B4	112
575	12	3.2	4.9	1190	C112_ 4.9 S1 M1LA2	111	C112_ 4.9 P80 BN80A2	112
767	9	3.8	3.7	1090	C112_ 3.7 S1 M1LA2	111	C112_ 3.7 P80 BN80A2	112
1012	7	4.5	2.8	1010	C112_ 2.8 S1 M1LA2	111	C112_ 2.8 P80 BN80A2	112

## 1.1 kW

0.85	11232	1.1	1081	85000	C1004_ 1081 S3 M3SA6	141	C1004_ 1081 P90 BN90L6	142
1.0	9437	1.3	908.2	85000	C1004_ 908.2 S3 M3SA6	141	C1004_ 908.2 P90 BN90L6	142
1.2	7764	0.9	1137	60000	C904_ 1137 S2 M2SB4	138	C904_ 1137 P90 BN90S4	139
1.3	7381	1.6	1081	85000	C1004_ 1081 S2 M2SB4	141	C1004_ 1081 P90 BN90S4	142
1.4	6869	1.0	1006	60000	C904_ 1006 S2 M2SB4	138	C904_ 1006 P90 BN90S4	139
1.4	6856	1.8	1004	85000	C1004_ 1004 S2 M2SB4	141	C1004_ 1004 P90 BN90S4	142
1.7	5763	1.2	844.0	60000	C904_ 844.0 S2 M2SB4	138	C904_ 844.0 P90 BN90S4	139
1.7	5758	2.1	843.3	85000	C1004_ 843.3 S2 M2SB4	141	C1004_ 843.3 P90 BN90S4	142
2.1	4457	1.6	652.8	60000	C904_ 652.8 S2 M2SB4	138	C904_ 652.8 P90 BN90S4	139
2.2	4284	2.8	627.4	85000	C1004_ 627.4 S2 M2SB4	141	C1004_ 627.4 P90 BN90S4	142
2.6	3648	2.0	534.2	60000	C904_ 534.2 S2 M2SB4	138	C904_ 534.2 P90 BN90S4	139
2.6	3614	1.1	529.3	35000	C804_ 529.3 S2 M2SB4	135	C804_ 529.3 P90 BN90S4	136
3.3	2861	2.5	419.0	60000	C904_ 419.0 S2 M2SB4	138	C904_ 419.0 P90 BN90S4	139
3.4	2851	1.4	417.5	35000	C804_ 417.5 S2 M2SB4	135	C804_ 417.5 P90 BN90S4	136
3.8	2490	1.6	364.7	35000	C804_ 364.7 S2 M2SB4	135	C804_ 364.7 P90 BN90S4	136
4.1	2351	1.0	344.3	25000	C704_ 344.3 S2 M2SB4	132	C704_ 344.3 P90 BN90S4	133
4.2	2283	1.8	334.3	35000	C804_ 334.3 S2 M2SB4	135	C804_ 334.3 P90 BN90S4	136
4.4	2171	1.1	317.9	25000	C704_ 317.9 S2 M2SB4	132	C704_ 317.9 P90 BN90S4	133
4.6	2060	0.8	301.7	16000	C614_ 301.7 S2 M2SB4	129	C614_ 301.7 P90 BN90S4	130
4.9	1951	2.1	285.7	35000	C804_ 285.7 S2 M2SB4	135	C804_ 285.7 P90 BN90S4	136
5.1	1880	0.9	275.3	16000	C614_ 275.3 S2 M2SB4	129	C614_ 275.3 P90 BN90S4	130
5.1	1859	1.2	272.2	25000	C704_ 272.2 S2 M2SB4	132	C704_ 272.2 P90 BN90S4	133
5.6	1716	1.3	251.3	25000	C704_ 251.3 S2 M2SB4	132	C704_ 251.3 P90 BN90S4	133
5.6	1746	0.9	164.5	16000	C613_ 164.5 S3 M3SA6	129	C613_ 164.5 P90 BN90L6	130
6.1	1593	1.0	150.0	16000	C613_ 150.0 S3 M3SA6	129	C613_ 150.0 P90 BN90L6	130
6.3	1542	1.5	220.9	25000	C703_ 220.9 S2 M2SB4	132	C703_ 220.9 P90 BN90S4	133
7.2	1366	1.2	195.8	16000	C613_ 195.8 S2 M2SB4	129	C613_ 195.8 P90 BN90S4	130
7.8	1250	1.8	179.2	25000	C703_ 179.2 S2 M2SB4	132	C703_ 179.2 P90 BN90S4	133
7.8	1246	1.3	178.6	16000	C613_ 178.6 S2 M2SB4	129	C613_ 178.6 P90 BN90S4	130
8.5	1148	1.4	164.5	16000	C613_ 164.5 S2 M2SB4	129	C613_ 164.5 P90 BN90S4	130
9.3	1049	2.2	150.3	25000	C703_ 150.3 S2 M2SB4	132	C703_ 150.3 P90 BN90S4	133
9.3	1047	1.5	150.0	16000	C613_ 150.0 S2 M2SB4	129	C613_ 150.0 P90 BN90S4	130
9.5	1029	1.0	147.4	10000	C513_ 147.4 S2 M2SB4	126	C513_ 147.4 P90 BN90S4	127
10.0	980	1.6	140.5	16000	C613_ 140.5 S2 M2SB4	129	C613_ 140.5 P90 BN90S4	130
10.4	939	1.1	134.6	10000	C513_ 134.6 S2 M2SB4	126	C513_ 134.6 P90 BN90S4	127
10.9	894	1.8	128.1	16000	C613_ 128.1 S2 M2SB4	129	C613_ 128.1 P90 BN90S4	130
11.0	885	2.6	126.8	25000	C703_ 126.8 S2 M2SB4	132	C703_ 126.8 P90 BN90S4	133
11.3	868	1.2	124.4	10000	C513_ 124.4 S2 M2SB4	126	C513_ 124.4 P90 BN90S4	127
12.3	793	2.0	113.6	16000	C613_ 113.6 S2 M2SB4	129	C613_ 113.6 P90 BN90S4	130
12.3	793	1.3	113.6	10000	C513_ 113.6 S2 M2SB4	126	C513_ 113.6 P90 BN90S4	127
12.5	785	2.9	112.4	25000	C703_ 112.4 S2 M2SB4	132	C703_ 112.4 P90 BN90S4	133
13.5	723	2.2	103.6	16000	C613_ 103.6 S2 M2SB4	129	C613_ 103.6 P90 BN90S4	130
13.8	710	1.4	101.8	10000	C513_ 101.8 S2 M2SB4	126	C513_ 101.8 P90 BN90S4	127
15.0	651	0.9	93.3	7000	C413_ 93.3 S2 M2SB4	123	C413_ 93.3 P90 BN90S4	124
15.1	649	1.5	93.0	10000	C513_ 93.0 S2 M2SB4	126	C513_ 93.0 P90 BN90S4	127
15.4	635	2.5	91.0	16000	C613_ 91.0 S2 M2SB4	129	C613_ 91.0 P90 BN90S4	130
16.9	579	2.8	83.0	16000	C613_ 83.0 S2 M2SB4	129	C613_ 83.0 P90 BN90S4	130
17.2	569	1.1	81.5	7000	C413_ 81.5 S2 M2SB4	123	C413_ 81.5 P90 BN90S4	124
17.5	557	1.8	79.9	10000	C513_ 79.9 S2 M2SB4	126	C513_ 79.9 P90 BN90S4	127
18.8	519	1.2	74.4	7000	C413_ 74.4 S2 M2SB4	123	C413_ 74.4 P90 BN90S4	124
18.9	518	3.1	74.2	16000	C613_ 74.2 S2 M2SB4	129	C613_ 74.2 P90 BN90S4	130
19.2	509	2.0	72.9	10000	C513_ 72.9 S2 M2SB4	126	C513_ 72.9 P90 BN90S4	127
19.8	493	0.9	70.7	6500	C353_ 70.7 S2 M2SB4	120	C353_ 70.7 P90 BN90S4	121
20.7	472	3.4	67.7	16000	C613_ 67.7 S2 M2SB4	129	C613_ 67.7 P90 BN90S4	130
21.7	451	2.2	64.6	10000	C513_ 64.6 S2 M2SB4	126	C513_ 64.6 P90 BN90S4	127

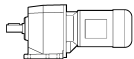



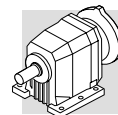

## 1.1 kW

$n_2$ min <sup>-1</sup>	$M_2$ Nm	S	i	$R_{n2}$ N				
21.8	449	1.3	64.3	7000	C413_ 64.3 S2 M2SB4	123	C413_ 64.3 P90 BN90S4	124
22.6	433	1.0	62.0	6500	C353_ 62.0 S2 M2SB4	120	C353_ 62.0 P90 BN90S4	121
23.7	412	2.4	59.0	10000	C513_ 59.0 S2 M2SB4	126	C513_ 59.0 P90 BN90S4	127
23.9	409	1.5	58.7	7000	C413_ 58.7 S2 M2SB4	123	C413_ 58.7 P90 BN90S4	124
24.6	406	1.9	57.0	10000	C512_ 57.0 S2 M2SB4	126	C512_ 57.0 P90 BN90S4	127
24.8	394	1.1	56.5	6500	C353_ 56.5 S2 M2SB4	120	C353_ 56.5 P90 BN90S4	121
27.2	359	1.7	51.5	7000	C413_ 51.5 S2 M2SB4	123	C413_ 51.5 P90 BN90S4	124
27.2	366	1.9	51.4	10000	C512_ 51.4 S2 M2SB4	126	C512_ 51.4 P90 BN90S4	127
27.4	357	2.8	51.2	10000	C513_ 51.2 S2 M2SB4	126	C513_ 51.2 P90 BN90S4	127
29.1	336	1.3	48.2	6500	C353_ 48.2 S2 M2SB4	120	C353_ 48.2 P90 BN90S4	121
29.3	341	2.3	47.8	10000	C512_ 47.8 S2 M2SB4	126	C512_ 47.8 P90 BN90S4	127
29.8	328	1.8	47.0	7000	C413_ 47.0 S2 M2SB4	123	C413_ 47.0 P90 BN90S4	124
30	326	3.1	46.7	10000	C513_ 46.7 S2 M2SB4	126	C513_ 46.7 P90 BN90S4	127
31	323	0.9	45.3	5500	C312_ 45.3 S2 M2SB4	117	C312_ 45.3 P90 BN90S4	118
31	319	1.6	44.8	7000	C412_ 44.8 S2 M2SB4	123	C412_ 44.8 P90 BN90S4	124
32	306	1.5	43.9	6500	C353_ 43.9 S2 M2SB4	120	C353_ 43.9 P90 BN90S4	121
32	307	2.5	43.1	10000	C512_ 43.1 S2 M2SB4	126	C512_ 43.1 P90 BN90S4	127
34	290	1.0	40.7	5500	C312_ 40.7 S2 M2SB4	117	C312_ 40.7 P90 BN90S4	118
35	288	2.8	40.4	10000	C512_ 40.4 S2 M2SB4	126	C512_ 40.4 P90 BN90S4	127
35	281	2.1	40.3	7000	C413_ 40.3 S2 M2SB4	123	C413_ 40.3 P90 BN90S4	124
37	266	1.7	38.1	6500	C353_ 38.1 S2 M2SB4	120	C353_ 38.1 P90 BN90S4	121
38	264	1.9	37.1	7000	C412_ 37.1 S2 M2SB4	123	C412_ 37.1 P90 BN90S4	124
38	257	2.3	36.8	7000	C413_ 36.8 S2 M2SB4	123	C413_ 36.8 P90 BN90S4	124
39	257	1.2	36.1	5500	C312_ 36.1 S2 M2SB4	117	C312_ 36.1 P90 BN90S4	118
40	242	1.9	34.7	6430	C353_ 34.7 S2 M2SB4	120	C353_ 34.7 P90 BN90S4	121
42	238	2.1	33.4	7000	C412_ 33.4 S2 M2SB4	123	C412_ 33.4 P90 BN90S4	124
43	232	1.3	32.5	5440	C312_ 32.5 S2 M2SB4	117	C312_ 32.5 P90 BN90S4	118
45	224	2.2	31.4	7000	C412_ 31.4 S2 M2SB4	123	C412_ 31.4 P90 BN90S4	124
45	218	2.6	31.2	7000	C413_ 31.2 S2 M2SB4	123	C413_ 31.2 P90 BN90S4	124
47	211	0.9	29.6	3190	C212_ 29.6 S2 M2SB4	114	C212_ 29.6 P90 BN90S4	115
47	212	1.4	29.8	5360	C312_ 29.8 S2 M2SB4	117	C312_ 29.8 P90 BN90S4	118
49	200	2.2	28.7	6190	C353_ 28.7 S2 M2SB4	120	C353_ 28.7 P90 BN90S4	121
49	199	2.8	28.5	7000	C413_ 28.5 S2 M2SB4	123	C413_ 28.5 P90 BN90S4	124
49	202	2.5	28.3	7000	C412_ 28.3 S2 M2SB4	123	C412_ 28.3 P90 BN90S4	124
52	190	1.1	26.7	3160	C212_ 26.7 S2 M2SB4	114	C212_ 26.7 P90 BN90S4	115
52	191	1.6	26.8	5230	C312_ 26.8 S2 M2SB4	117	C312_ 26.8 P90 BN90S4	118
56	179	1.7	25.1	5180	C312_ 25.1 S2 M2SB4	117	C312_ 25.1 P90 BN90S4	118
58	173	1.2	24.3	3150	C212_ 24.3 S2 M2SB4	114	C212_ 24.3 P90 BN90S4	115
62	161	1.9	22.6	5050	C312_ 22.6 S2 M2SB4	117	C312_ 22.6 P90 BN90S4	118
62	161	3.1	22.6	6810	C412_ 22.6 S2 M2SB4	123	C412_ 22.6 P90 BN90S4	124
64	156	1.3	21.9	3100	C212_ 21.9 S2 M2SB4	114	C212_ 21.9 P90 BN90S4	115
70	143	1.3	20.0	3080	C212_ 20.0 S2 M2SB4	114	C212_ 20.0 P90 BN90S4	115
70	143	2.1	20.1	4920	C312_ 20.1 S2 M2SB4	117	C312_ 20.1 P90 BN90S4	118
74	135	2.8	19.0	5580	C352_ 19.0 S2 M2SB4	110	C352_ 19.0 P90 BN90S4	121
77	129	2.2	18.1	4790	C312_ 18.1 S2 M2SB4	117	C312_ 18.1 P90 BN90S4	118
78	129	1.4	18.0	3020	C212_ 18.0 S2 M2SB4	114	C212_ 18.0 P90 BN90S4	115
82	122	3.1	17.1	5420	C352_ 17.1 S2 M2SB4	110	C352_ 17.1 P90 BN90S4	121
88	113	1.6	15.8	2970	C212_ 15.8 S2 M2SB4	114	C212_ 15.8 P90 BN90S4	115
90	111	2.4	15.6	4630	C312_ 15.6 S2 M2SB4	117	C312_ 15.6 P90 BN90S4	118
98	102	1.7	14.3	2910	C212_ 14.3 S2 M2SB4	114	C212_ 14.3 P90 BN90S4	115
100	100	2.6	14.0	4500	C312_ 14.0 S2 M2SB4	117	C312_ 14.0 P90 BN90S4	118
113	88	1.8	12.4	2840	C212_ 12.4 S2 M2SB4	114	C212_ 12.4 P90 BN90S4	115
114	88	2.8	12.3	4350	C312_ 12.3 S2 M2SB4	117	C312_ 12.3 P90 BN90S4	118
125	80	1.9	11.2	2770	C212_ 11.2 S2 M2SB4	114	C212_ 11.2 P90 BN90S4	115
126	79	3.0	11.1	4230	C312_ 11.1 S2 M2SB4	117	C312_ 11.1 P90 BN90S4	118
139	72	0.9	10.1	1400	C112_ 10.1 S2 M2SB4	111	C112_ 10.1 P90 BN90S4	112
145	69	2.1	9.6	2700	C212_ 9.6 S2 M2SB4	114	C212_ 9.6 P90 BN90S4	115
151	66	3.3	9.3	4030	C312_ 9.3 S2 M2SB4	117	C312_ 9.3 P90 BN90S4	118
154	65	0.9	9.1	1480	C112_ 9.1 S2 M2SB4	111	C112_ 9.1 P90 BN90S4	112
161	62	2.3	8.7	2630	C212_ 8.7 S2 M2SB4	114	C212_ 8.7 P90 BN90S4	115
184	54	1.0	7.6	1550	C112_ 7.6 S2 M2SB4	111	C112_ 7.6 P90 BN90S4	112
198	50	2.6	7.1	2510	C212_ 7.1 S2 M2SB4	114	C212_ 7.1 P90 BN90S4	115
204	49	1.1	6.9	1510	C112_ 6.9 S2 M2SB4	111	C112_ 6.9 P90 BN90S4	112
220	45	2.7	6.4	2440	C212_ 6.4 S2 M2SB4	114	C212_ 6.4 P90 BN90S4	115
223	45	3.5	6.3	3560	C312_ 6.3 S2 M2SB4	117	C312_ 6.3 P90 BN90S4	118

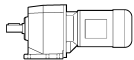

## 1.1 kW

$n_2$ min <sup>-1</sup>	$M_2$ Nm	S	i	$R_{n2}$ N				
225	44	1.2	6.2	1220	C112_ 6.2 S2 M2SB4	111	C112_ 6.2 P90 BN90S4	112
230	43	2.4	6.1	2380	C212_ 6.1 S2 M2SB4	114	C212_ 6.1 P90 BN90S4	115
232	43	1.2	12.1	1470	C112_ 12.1 S2 M2SA2	111	C112_ 12.1 P80 BN80B2	112
251	40	3.1	11.2	2360	C212_ 11.2 S2 M2SA2	114	C212_ 11.2 P80 BN80B2	115
252	40	1.2	3.7	1320	C112_ 3.7 S3 M3SA6	111	C112_ 3.7 P90 BN90L6	112
278	36	1.4	10.1	1420	C112_ 10.1 S2 M2SA2	111	C112_ 10.1 P80 BN80B2	112
288	35	1.4	4.9	1370	C112_ 4.9 S2 M2SB4	111	C112_ 4.9 P90 BN90S4	112
294	34	2.9	4.8	2240	C212_ 4.8 S2 M2SB4	114	C212_ 4.8 P90 BN90S4	115
309	32	1.5	9.1	1380	C112_ 9.1 S2 M2SA2	111	C112_ 9.1 P80 BN80B2	112
332	30	1.4	2.8	1320	C112_ 2.8 S3 M3SA6	111	C112_ 2.8 P90 BN90L6	112
338	30	3.2	2.7	2160	C212_ 2.7 S3 M3SA6	114	C212_ 2.7 P90 BN90L6	115
367	27	1.7	7.6	1330	C112_ 7.6 S2 M2SA2	111	C112_ 7.6 P80 BN80B2	112
378	26	3.4	3.7	2090	C212_ 3.7 S2 M2SB4	114	C212_ 3.7 P90 BN90S4	115
383	26	1.6	3.7	1280	C112_ 3.7 S2 M2SB4	111	C112_ 3.7 P90 BN90S4	112
408	24	1.8	6.9	1290	C112_ 6.9 S2 M2SA2	111	C112_ 6.9 P80 BN80B2	112
449	22	1.9	6.2	1230	C112_ 6.2 S2 M2SA2	111	C112_ 6.2 P80 BN80B2	112
506	20	1.9	2.8	1190	C112_ 2.8 S2 M2SB4	111	C112_ 2.8 P90 BN90S4	112
575	17	2.2	4.9	1150	C112_ 4.9 S2 M2SA2	111	C112_ 4.9 P80 BN80B2	112
767	13	2.6	3.7	1070	C112_ 3.7 S2 M2SA2	111	C112_ 3.7 P80 BN80B2	112
1012	10	3.0	2.8	980	C112_ 2.8 S2 M2SA2	111	C112_ 2.8 P80 BN80B2	112



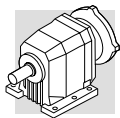

## 1.5 kW

1.0	12595	1.0	908.2	85000	C1004_ 908.2 S3 M3LA6	141	C1004_ 908.2 P100 BN100LA6	142
1.3	9994	1.2	1081	85000	C1004_ 1081 S3 M3SA4	141	C1004_ 1081 P90 BN90LA4	142
1.6	8397	1.4	908.2	85000	C1004_ 908.2 S3 M3SA4	141	C1004_ 908.2 P90 BN90LA4	142
1.7	7803	0.9	844.0	60000	C904_ 844.0 S3 M3SA4	138	C904_ 844.0 P90 BN90LA4	139
2.0	6659	1.8	720.3	85000	C1004_ 720.3 S3 M3SA4	141	C1004_ 720.3 P90 BN90LA4	142
2.0	6584	1.1	712.2	60000	C904_ 712.2 S3 M3SA4	138	C904_ 712.2 P90 BN90LA4	139
2.6	4939	1.5	534.2	60000	C904_ 534.2 S3 M3SA4	138	C904_ 534.2 P90 BN90LA4	139
3.1	4226	1.7	457.1	60000	C904_ 457.1 S3 M3SA4	138	C904_ 457.1 P90 BN90LA4	139
3.1	4210	1.0	455.4	35000	C804_ 455.4 S3 M3SA4	135	C804_ 455.4 P90 BN90LA4	136
3.4	3874	1.9	419.0	60000	C904_ 419.0 S3 M3SA4	138	C904_ 419.0 P90 BN90LA4	139
3.4	3860	1.0	417.5	35000	C804_ 417.5 S3 M3SA4	135	C804_ 417.5 P90 BN90LA4	136
4.2	3134	2.3	339.0	60000	C904_ 339.0 S3 M3SA4	138	C904_ 339.0 P90 BN90LA4	139
4.2	3091	1.3	334.3	35000	C804_ 334.3 S3 M3SA4	135	C804_ 334.3 P90 BN90LA4	136
4.8	2708	2.7	292.9	60000	C904_ 292.9 S3 M3SA4	138	C904_ 292.9 P90 BN90LA4	139
4.9	2641	1.5	285.7	35000	C804_ 285.7 S3 M3SA4	135	C804_ 285.7 P90 BN90LA4	136
5.2	2517	0.9	272.2	25000	C704_ 272.2 S3 M3SA4	132	C704_ 272.2 P90 BN90LA4	133
5.4	2421	1.7	261.9	35000	C804_ 261.9 S3 M3SA4	135	C804_ 261.9 P90 BN90LA4	136
5.6	2323	1.0	251.3	25000	C704_ 251.3 S3 M3SA4	132	C704_ 251.3 P90 BN90LA4	133
5.9	2261	1.0	239.3	25000	C703_ 239.3 S3 M3SA4	132	C703_ 239.3 P90 BN90LA4	133
6.5	2010	0.8	217.4	16000	C614_ 217.4 S3 M3SA4	129	C614_ 217.4 P90 BN90LA4	130
6.5	2039	2.0	215.8	35000	C803_ 215.8 S3 M3SA4	135	C803_ 215.8 P90 BN90LA4	136
7.3	1834	1.3	194.1	25000	C703_ 194.1 S3 M3SA4	132	C703_ 194.1 P90 BN90LA4	133
7.9	1693	1.4	179.2	25000	C703_ 179.2 S3 M3SA4	132	C703_ 179.2 P90 BN90LA4	133
7.9	1687	0.9	178.6	16000	C613_ 178.6 S3 M3SA4	129	C613_ 178.6 P90 BN90LA4	130
8.3	1597	2.5	169.0	35000	C803_ 169.0 S3 M3SA4	135	C803_ 169.0 P90 BN90LA4	136
8.6	1554	1.0	164.5	16000	C613_ 164.5 S3 M3SA4	129	C613_ 164.5 P90 BN90LA4	130
9.4	1420	1.6	150.3	25000	C703_ 150.3 S3 M3SA4	132	C703_ 150.3 P90 BN90LA4	133
9.4	1418	1.1	150.0	16000	C613_ 150.0 S3 M3SA4	129	C613_ 150.0 P90 BN90LA4	130
9.5	1409	2.8	149.1	35000	C803_ 149.1 S3 M3SA4	135	C803_ 149.1 P90 BN90LA4	136
10.0	1327	1.2	140.5	16000	C613_ 140.5 S3 M3SA4	129	C613_ 140.5 P90 BN90LA4	130
10.3	1298	1.8	137.4	25000	C703_ 137.4 S3 M3SA4	132	C703_ 137.4 P90 BN90LA4	133
10.3	1291	3.1	136.7	35000	C803_ 136.7 S3 M3SA4	135	C803_ 136.7 P90 BN90LA4	136
11.0	1211	1.3	128.1	16000	C613_ 128.1 S3 M3SA4	129	C613_ 128.1 P90 BN90LA4	130
11.1	1198	1.9	126.8	25000	C703_ 126.8 S3 M3SA4	132	C703_ 126.8 P90 BN90LA4	133
12.4	1073	1.5	113.6	16000	C613_ 113.6 S3 M3SA4	129	C613_ 113.6 P90 BN90LA4	130
12.4	1073	0.9	113.6	10000	C513_ 113.6 S3 M3SA4	126	C513_ 113.6 P90 BN90LA4	127
13.6	981	2.3	103.8	25000	C703_ 103.8 S3 M3SA4	132	C703_ 103.8 P90 BN90LA4	133
13.6	979	1.6	103.6	16000	C613_ 103.6 S3 M3SA4	129	C613_ 103.6 P90 BN90LA4	130
13.8	962	1.0	101.8	10000	C513_ 101.8 S3 M3SA4	126	C513_ 101.8 P90 BN90LA4	127
15.2	878	1.1	93.0	10000	C513_ 93.0 S3 M3SA4	126	C513_ 93.0 P90 BN90LA4	127



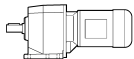



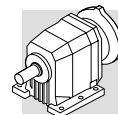

# 1.5 kW

$n_2$ min <sup>-1</sup>	$M_2$ Nm	S	i	$R_{n2}$ N				
15.5	860	1.9	91.0	16000	C613_ 91.0 S3 M3SA4	129	C613_ 91.0 P90 BN90LA4	130
16.0	833	2.8	88.2	25000	C703_ 88.2 S3 M3SA4	132	C703_ 88.2 P90 BN90LA4	133
16.5	826	1.0	57.0	10000	C512_ 57.0 S3 M3LA6	126	C512_ 57.0 P100 BN100LA6	127
17.0	785	2.0	83.0	16000	C613_ 83.0 S3 M3SA4	129	C613_ 83.0 P90 BN90LA4	130
17.3	769	3.0	81.4	25000	C703_ 81.4 S3 M3SA4	132	C703_ 81.4 P90 BN90LA4	133
17.7	755	1.3	79.9	10000	C513_ 79.9 S3 M3SA4	126	C513_ 79.9 P90 BN90LA4	127
18.3	744	1.0	51.4	10000	C512_ 51.4 S3 M3LA6	126	C512_ 51.4 P100 BN100LA6	127
19.0	701	2.3	74.2	16000	C613_ 74.2 S3 M3SA4	129	C613_ 74.2 P90 BN90LA4	130
19.3	689	1.5	72.9	10000	C513_ 72.9 S3 M3SA4	126	C513_ 72.9 P90 BN90LA4	127
19.7	692	1.2	47.8	10000	C512_ 47.8 S3 M3LA6	126	C512_ 47.8 P100 BN100LA6	127
19.8	674	3.4	71.3	25000	C703_ 71.3 S3 M3SA4	132	C703_ 71.3 P90 BN90LA4	133
20.8	640	2.5	67.7	16000	C613_ 67.7 S3 M3SA4	129	C613_ 67.7 P90 BN90LA4	130
21.8	624	1.3	43.1	10000	C512_ 43.1 S3 M3LA6	126	C512_ 43.1 P100 BN100LA6	127
21.8	610	1.6	64.6	10000	C513_ 64.6 S3 M3SA4	126	C513_ 64.6 P90 BN90LA4	127
21.9	607	1.0	64.3	7000	C413_ 64.3 S3 M3SA4	123	C413_ 64.3 P90 BN90LA4	124
23.9	557	1.8	59.0	10000	C513_ 59.0 S3 M3SA4	126	C513_ 59.0 P90 BN90LA4	127
24.0	554	1.1	58.7	7000	C413_ 58.7 S3 M3SA4	123	C413_ 58.7 P90 BN90LA4	124
24.1	554	2.9	58.6	16000	C613_ 58.6 S3 M3SA4	129	C613_ 58.6 P90 BN90LA4	130
24.7	550	1.4	57.0	10000	C512_ 57.0 S3 M3SA4	126	C512_ 57.0 P90 BN90LA4	127
26.4	505	3.2	53.5	16000	C613_ 53.5 S3 M3SA4	129	C613_ 53.5 P90 BN90LA4	130
27.4	486	1.2	51.5	7000	C413_ 51.5 S3 M3SA4	123	C413_ 51.5 P90 BN90LA4	124
27.4	496	1.4	51.4	10000	C512_ 51.4 S3 M3SA4	126	C512_ 51.4 P90 BN90LA4	127
27.6	483	2.1	51.2	10000	C513_ 51.2 S3 M3SA4	126	C513_ 51.2 P90 BN90LA4	127
29.3	455	1.0	48.2	6290	C353_ 48.2 S3 M3SA4	120	C353_ 48.2 P90 BN90LA4	121
29.5	462	1.7	47.8	10000	C512_ 47.8 S3 M3SA4	126	C512_ 47.8 P90 BN90LA4	127
30	444	1.4	47.0	7000	C413_ 47.0 S3 M3SA4	123	C413_ 47.0 P90 BN90LA4	124
30	441	2.3	46.7	10000	C513_ 46.7 S3 M3SA4	126	C513_ 46.7 P90 BN90LA4	127
32	432	1.2	44.8	7000	C412_ 44.8 S3 M3SA4	123	C412_ 44.8 P90 BN90LA4	124
32	415	1.1	43.9	6190	C353_ 43.9 S3 M3SA4	120	C353_ 43.9 P90 BN90LA4	121
33	416	1.9	43.1	10000	C512_ 43.1 S3 M3SA4	126	C512_ 43.1 P90 BN90LA4	127
35	382	2.6	40.5	10000	C513_ 40.5 S3 M3SA4	126	C513_ 40.5 P90 BN90LA4	127
35	390	2.0	40.4	10000	C512_ 40.4 S3 M3SA4	126	C512_ 40.4 P90 BN90LA4	127
35	381	1.6	40.3	7000	C413_ 40.3 S3 M3SA4	123	C413_ 40.3 P90 BN90LA4	124
37	360	1.3	38.1	6110	C353_ 38.1 S3 M3SA4	120	C353_ 38.1 P90 BN90LA4	121
38	358	1.4	37.1	7000	C412_ 37.1 S3 M3SA4	123	C412_ 37.1 P90 BN90LA4	124
38	348	1.7	36.8	7000	C413_ 36.8 S3 M3SA4	123	C413_ 36.8 P90 BN90LA4	124
39	351	2.2	36.4	10000	C512_ 36.4 S3 M3SA4	126	C512_ 36.4 P90 BN90LA4	127
41	328	1.4	34.7	5990	C353_ 34.7 S3 M3SA4	120	C353_ 34.7 P90 BN90LA4	121
42	322	1.6	33.4	7000	C412_ 33.4 S3 M3SA4	123	C412_ 33.4 P90 BN90LA4	124
43	319	2.5	33.0	10000	C512_ 33.0 S3 M3SA4	126	C512_ 33.0 P90 BN90LA4	127
43	314	1.0	32.5	5000	C312_ 32.5 S3 M3SA4	117	C312_ 32.5 P90 BN90LA4	118
45	303	1.6	31.4	6990	C412_ 31.4 S3 M3SA4	123	C412_ 31.4 P90 BN90LA4	124
45	295	1.9	31.2	7000	C413_ 31.2 S3 M3SA4	123	C413_ 31.2 P90 BN90LA4	124
47	287	1.0	29.8	4970	C312_ 29.8 S3 M3SA4	117	C312_ 29.8 P90 BN90LA4	118
47	287	2.8	29.8	10000	C512_ 29.8 S3 M3SA4	126	C512_ 29.8 P90 BN90LA4	127
49	271	1.7	28.7	5830	C353_ 28.7 S3 M3SA4	120	C353_ 28.7 P90 BN90LA4	121
50	273	1.8	28.3	6830	C412_ 28.3 S3 M3SA4	123	C412_ 28.3 P90 BN90LA4	124
53	259	1.2	26.8	4870	C312_ 26.8 S3 M3SA4	117	C312_ 26.8 P90 BN90LA4	118
54	247	1.8	26.2	5710	C353_ 26.2 S3 M3SA4	120	C353_ 26.2 P90 BN90LA4	121
54	250	3.2	25.9	10000	C512_ 25.9 S3 M3SA4	126	C512_ 25.9 P90 BN90LA4	127
56	242	1.2	25.1	4840	C312_ 25.1 S3 M3SA4	117	C312_ 25.1 P90 BN90LA4	118
56	242	2.1	25.0	6680	C412_ 25.0 S3 M3SA4	123	C412_ 25.0 P90 BN90LA4	124
62	218	1.4	22.6	4740	C312_ 22.6 S3 M3SA4	117	C312_ 22.6 P90 BN90LA4	118
63	218	2.3	22.6	6510	C412_ 22.6 S3 M3SA4	123	C412_ 22.6 P90 BN90LA4	124
64	209	2.1	22.1	5530	C353_ 22.1 S3 M3SA4	120	C353_ 22.1 P90 BN90LA4	121
65	211	0.9	21.9	2560	C212_ 21.9 S3 M3SA4	114	C212_ 21.9 P90 BN90LA4	115
70	191	2.1	20.2	5410	C353_ 20.2 S3 M3SA4	120	C353_ 20.2 P90 BN90LA4	121
70	193	1.0	20.0	2740	C212_ 20.0 S3 M3SA4	114	C212_ 20.0 P90 BN90LA4	115
70	194	1.5	20.1	4650	C312_ 20.1 S3 M3SA4	117	C312_ 20.1 P90 BN90LA4	118
71	191	2.5	19.8	6330	C412_ 19.8 S3 M3SA4	123	C412_ 19.8 P90 BN90LA4	124
74	183	2.1	19.0	5330	C352_ 19.0 S3 M3SA4	110	C352_ 19.0 P90 BN90LA4	121
78	174	1.1	18.0	2710	C212_ 18.0 S3 M3SA4	114	C212_ 18.0 P90 BN90LA4	115
78	174	1.6	18.1	4540	C312_ 18.1 S3 M3SA4	117	C312_ 18.1 P90 BN90LA4	118
79	172	2.8	17.8	6160	C412_ 17.8 S3 M3SA4	123	C412_ 17.8 P90 BN90LA4	124
82	165	2.3	17.1	5190	C352_ 17.1 S3 M3SA4	110	C352_ 17.1 P90 BN90LA4	121

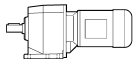

## 1.5 kW



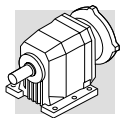

$n_2$ min <sup>-1</sup>	$M_2$ Nm	S	i	$R_{n2}$ N				
89	153	1.1	15.8	2700	C212_ 15.8 S3 M3SA4	114	C212_ 15.8 P90 BN90LA4	115
89	153	2.9	15.8	6000	C412_ 15.8 S3 M3SA4	123	C412_ 15.8 P90 BN90LA4	124
90	150	1.8	15.6	4410	C312_ 15.6 S3 M3SA4	117	C312_ 15.6 P90 BN90LA4	118
96	142	2.7	14.8	5030	C352_ 14.8 S3 M3SA4	110	C352_ 14.8 P90 BN90LA4	121
99	137	3.2	14.2	5830	C412_ 14.2 S3 M3SA4	123	C412_ 14.2 P90 BN90LA4	124
99	138	1.2	14.3	2660	C212_ 14.3 S3 M3SA4	114	C212_ 14.3 P90 BN90LA4	115
100	135	1.9	14.0	4300	C312_ 14.0 S3 M3SA4	117	C312_ 14.0 P90 BN90LA4	118
106	128	3.0	13.3	4890	C352_ 13.3 S3 M3SA4	110	C352_ 13.3 P90 BN90LA4	121
114	120	1.3	12.4	2630	C212_ 12.4 S3 M3SA4	114	C212_ 12.4 P90 BN90LA4	115
114	119	2.1	12.3	4180	C312_ 12.3 S3 M3SA4	117	C312_ 12.3 P90 BN90LA4	118
121	113	3.4	11.7	4740	C352_ 11.7 S3 M3SA4	110	C352_ 11.7 P90 BN90LA4	121
126	108	1.4	11.2	2580	C212_ 11.2 S3 M3SA4	114	C212_ 11.2 P90 BN90LA4	115
127	107	2.2	11.1	4070	C312_ 11.1 S3 M3SA4	117	C312_ 11.1 P90 BN90LA4	118
146	93	1.6	9.6	2530	C212_ 9.6 S3 M3SA4	114	C212_ 9.6 P90 BN90LA4	115
152	90	2.5	9.3	3900	C312_ 9.3 S3 M3SA4	117	C312_ 9.3 P90 BN90LA4	118
162	84	1.7	8.7	2470	C212_ 8.7 S3 M3SA4	114	C212_ 8.7 P90 BN90LA4	115
168	81	2.7	8.4	3790	C312_ 8.4 S3 M3SA4	117	C312_ 8.4 P90 BN90LA4	118
177	77	1.8	15.8	2440	C212_ 15.8 S2 M2SB2	114	C212_ 15.8 P90 BN90SA2	115
190	72	2.3	5.0	3610	C312_ 5.0 S3 M3LA6	117	C312_ 5.0 P100 BN100LA6	118
197	69	2.9	7.2	3640	C312_ 7.2 S3 M3SA4	117	C312_ 7.2 P90 BN90LA4	118
199	68	1.9	7.1	2380	C212_ 7.1 S3 M3SA4	114	C212_ 7.1 P90 BN90LA4	115
203	67	3.0	4.6	4050	C352_ 4.6 S3 M3LA6	110	C352_ 4.6 P100 BN100LA6	121
205	66	0.8	6.9	1070	C112_ 6.9 S3 M3SA4	111	C112_ 6.9 P90 BN90LA4	112
219	62	3.1	6.5	3540	C312_ 6.5 S3 M3SA4	117	C312_ 6.5 P90 BN90LA4	118
221	62	2.0	6.4	2330	C212_ 6.4 S3 M3SA4	114	C212_ 6.4 P90 BN90LA4	115
225	60	2.6	6.3	3450	C312_ 6.3 S3 M3SA4	117	C312_ 6.3 P90 BN90LA4	118
232	59	0.9	12.1	1210	C112_ 12.1 S2 M2SB2	111	C112_ 12.1 P90 BN90SA2	112
232	59	1.8	6.1	2250	C212_ 6.1 S3 M3SA4	114	C212_ 6.1 P90 BN90LA4	115
254	54	2.0	3.7	2210	C212_ 3.7 S3 M3LA6	114	C212_ 3.7 P100 BN100LA6	115
278	49	1.0	10.1	1340	C112_ 10.1 S2 M2SB2	111	C112_ 10.1 P90 BN90SA2	112
285	48	3.2	5.0	3240	C312_ 5.0 S3 M3SA4	117	C312_ 5.0 P90 BN90LA4	118
290	47	1.0	4.9	840	C112_ 4.9 S3 M3SA4	111	C112_ 4.9 P90 BN90LA4	112
296	46	2.2	4.8	2140	C212_ 4.8 S3 M3SA4	114	C212_ 4.8 P90 BN90LA4	115
309	44	1.1	9.1	1310	C112_ 9.1 S2 M2SB2	111	C112_ 9.1 P90 BN90SA2	112
322	42	2.6	8.7	2130	C212_ 8.7 S2 M2SB2	114	C212_ 8.7 P90 BN90SA2	115
340	40	1.1	2.8	1000	C112_ 2.8 S3 M3LA6	111	C112_ 2.8 P100 BN100LA6	112
345	39	2.4	2.7	2060	C212_ 2.7 S3 M3LA6	114	C212_ 2.7 P100 BN100LA6	115
367	37	1.2	7.6	1270	C112_ 7.6 S2 M2SB2	111	C112_ 7.6 P90 BN90SA2	112
380	36	2.5	3.7	2020	C212_ 3.7 S3 M3SA4	114	C212_ 3.7 P90 BN90LA4	115
386	35	1.2	3.7	1100	C112_ 3.7 S3 M3SA4	111	C112_ 3.7 P90 BN90LA4	112
395	34	3.1	7.1	2030	C212_ 7.1 S2 M2SB2	114	C212_ 7.1 P90 BN90SA2	115
408	33	1.3	6.9	1230	C112_ 6.9 S2 M2SB2	111	C112_ 6.9 P90 BN90SA2	112
439	31	3.2	6.4	1970	C212_ 6.4 S2 M2SB2	114	C212_ 6.4 P90 BN90SA2	115
449	30	1.4	6.2	1180	C112_ 6.2 S2 M2SB2	111	C112_ 6.2 P90 BN90SA2	112
460	30	2.9	6.1	1920	C212_ 6.1 S2 M2SB2	114	C212_ 6.1 P90 BN90SA2	115
510	27	1.4	2.8	1140	C112_ 2.8 S3 M3SA4	111	C112_ 2.8 P90 BN90LA4	112
518	26	3.0	2.7	1870	C212_ 2.7 S3 M3SA4	114	C212_ 2.7 P90 BN90LA4	115
575	24	1.6	4.9	1110	C112_ 4.9 S2 M2SB2	111	C112_ 4.9 P90 BN90SA2	112
587	23	3.5	4.8	1810	C212_ 4.8 S2 M2SB2	114	C212_ 4.8 P90 BN90SA2	115
767	18	1.9	3.7	1030	C112_ 3.7 S2 M2SB2	111	C112_ 3.7 P90 BN90SA2	112
1012	13	2.2	2.8	960	C112_ 2.8 S2 M2SB2	111	C112_ 2.8 P90 BN90SA2	112

## 2.2 kW

1.6	12315	1.0	908.2	85000	C1004_ 908.2 S3 M3LA4	141	C1004_ 908.2 P100 BN100LA4	142
2.0	9767	1.2	720.3	85000	C1004_ 720.3 S3 M3LA4	141	C1004_ 720.3 P100 BN100LA4	142
2.4	7900	1.5	582.6	85000	C1004_ 582.6 S3 M3LA4	141	C1004_ 582.6 P100 BN100LA4	142
2.6	7244	1.0	534.2	60000	C904_ 534.2 S3 M3LA4	138	C904_ 534.2 P100 BN100LA4	139
3.1	6198	1.2	457.1	60000	C904_ 457.1 S3 M3LA4	138	C904_ 457.1 P100 BN100LA4	139
3.7	5159	2.3	380.5	85000	C1004_ 380.5 S3 M3LA4	141	C1004_ 380.5 P100 BN100LA4	142
3.8	5014	1.4	369.8	60000	C904_ 369.8 S3 M3LA4	138	C904_ 369.8 P100 BN100LA4	139
4.8	3972	1.8	292.9	60000	C904_ 292.9 S3 M3LA4	138	C904_ 292.9 P100 BN100LA4	139
4.9	3874	1.0	285.7	35000	C804_ 285.7 S3 M3LA4	135	C804_ 285.7 P100 BN100LA4	136

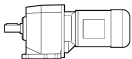



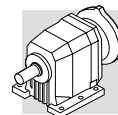

## 2.2 kW

$n_2$ min <sup>-1</sup>	$M_2$ Nm	S	i	$R_{n2}$ N				
5.4	3551	1.1	261.9	35000	C804_ 261.9 S3 M3LA4	135	C804_ 261.9 P100 BN100LA4	136
6.1	3142	2.3	231.7	60000	C904_ 231.7 S3 M3LA4	138	C904_ 231.7 P100 BN100LA4	139
6.5	2991	1.3	215.8	35000	C803_ 215.8 S3 M3LA4	135	C803_ 215.8 P100 BN100LA4	136
7.6	2555	1.6	184.4	35000	C803_ 184.4 S3 M3LA4	135	C803_ 184.4 P100 BN100LA4	136
7.9	2483	0.9	179.2	25000	C703_ 179.2 S3 M3LA4	132	C703_ 179.2 P100 BN100LA4	133
8.7	2256	1.0	162.8	25000	C703_ 162.8 S3 M3LA4	132	C703_ 162.8 P100 BN100LA4	133
10.3	1904	1.2	137.4	25000	C703_ 137.4 S3 M3LA4	132	C703_ 137.4 P100 BN100LA4	133
10.3	1894	2.1	136.7	35000	C803_ 136.7 S3 M3LA4	135	C803_ 136.7 P100 BN100LA4	136
11.0	1776	0.9	128.1	16000	C613_ 128.1 S3 M3LA4	129	C613_ 128.1 P100 BN100LA4	130
12.4	1574	1.0	113.6	16000	C613_ 113.6 S3 M3LA4	129	C613_ 113.6 P100 BN100LA4	130
12.5	1558	1.5	112.4	25000	C703_ 112.4 S3 M3LA4	132	C703_ 112.4 P100 BN100LA4	133
12.9	1517	2.6	109.5	35000	C803_ 109.5 S3 M3LA4	135	C803_ 109.5 P100 BN100LA4	136
13.6	1438	1.6	103.8	25000	C703_ 103.8 S3 M3LA4	132	C703_ 103.8 P100 BN100LA4	133
13.6	1436	1.1	103.6	16000	C613_ 103.6 S3 M3LA4	129	C613_ 103.6 P100 BN100LA4	130
14.5	1350	3.0	97.4	35000	C803_ 97.4 S3 M3LA4	135	C803_ 97.4 P100 BN100LA4	136
15.5	1261	1.3	91.0	16000	C613_ 91.0 S3 M3LA4	129	C613_ 91.0 P100 BN100LA4	130
15.8	1237	3.2	89.3	35000	C803_ 89.3 S3 M3LA4	135	C803_ 89.3 P100 BN100LA4	136
16.0	1222	1.9	88.2	25000	C703_ 88.2 S3 M3LA4	132	C703_ 88.2 P100 BN100LA4	133
17.0	1151	1.4	83.0	16000	C613_ 83.0 S3 M3LA4	129	C613_ 83.0 P100 BN100LA4	130
17.3	1128	2.0	81.4	25000	C703_ 81.4 S3 M3LA4	132	C703_ 81.4 P100 BN100LA4	133
17.7	1107	0.9	79.9	10000	C513_ 79.9 S3 M3LA4	126	C513_ 79.9 P100 BN100LA4	127
19.0	1028	1.6	74.2	16000	C613_ 74.2 S3 M3LA4	129	C613_ 74.2 P100 BN100LA4	130
19.3	1011	1.0	72.9	10000	C513_ 72.9 S3 M3LA4	126	C513_ 72.9 P100 BN100LA4	127
19.8	989	2.3	71.3	25000	C703_ 71.3 S3 M3LA4	132	C703_ 71.3 P100 BN100LA4	133
20.8	938	1.7	67.7	16000	C613_ 67.7 S3 M3LA4	129	C613_ 67.7 P100 BN100LA4	130
21.4	913	2.5	65.9	25000	C703_ 65.9 S3 M3LA4	132	C703_ 65.9 P100 BN100LA4	133
21.8	895	1.1	64.6	10000	C513_ 64.6 S3 M3LA4	126	C513_ 64.6 P100 BN100LA4	127
23.9	817	1.2	59.0	10000	C513_ 59.0 S3 M3LA4	126	C513_ 59.0 P100 BN100LA4	127
24.1	812	2.0	58.6	16000	C613_ 58.6 S3 M3LA4	129	C613_ 58.6 P100 BN100LA4	130
24.7	807	1.0	57.0	10000	C512_ 57.0 S3 M3LA4	126	C512_ 57.0 P100 BN100LA4	127
25.0	783	2.9	56.5	25000	C703_ 56.5 S3 M3LA4	132	C703_ 56.5 P100 BN100LA4	133
26.4	741	2.2	53.5	16000	C613_ 53.5 S3 M3LA4	129	C613_ 53.5 P100 BN100LA4	130
27.4	728	1.0	51.4	10000	C512_ 51.4 S3 M3LA4	126	C512_ 51.4 P100 BN100LA4	127
27.6	709	1.4	51.2	10000	C513_ 51.2 S3 M3LA4	126	C513_ 51.2 P100 BN100LA4	127
29.5	677	1.2	47.8	10000	C512_ 47.8 S3 M3LA4	126	C512_ 47.8 P100 BN100LA4	127
29.6	660	2.4	47.6	16000	C613_ 47.6 S3 M3LA4	129	C613_ 47.6 P100 BN100LA4	130
30	651	0.9	47.0	6440	C413_ 47.0 S3 M3LA4	123	C413_ 47.0 P100 BN100LA4	124
30	647	1.5	46.7	10000	C513_ 46.7 S3 M3LA4	126	C513_ 46.7 P100 BN100LA4	127
32	602	2.7	43.4	16000	C613_ 43.4 S3 M3LA4	129	C613_ 43.4 P100 BN100LA4	130
33	610	1.3	43.1	10000	C512_ 43.1 S3 M3LA4	126	C512_ 43.1 P100 BN100LA4	127
35	561	1.8	40.5	10000	C513_ 40.5 S3 M3LA4	126	C513_ 40.5 P100 BN100LA4	127
35	571	1.4	40.4	10000	C512_ 40.4 S3 M3LA4	126	C512_ 40.4 P100 BN100LA4	127
35	559	1.1	40.3	6460	C413_ 40.3 S3 M3LA4	123	C413_ 40.3 P100 BN100LA4	124
37	538	2.5	38.0	16000	C612_ 38.0 S3 M3LA4	129	C612_ 38.0 P100 BN100LA4	130
38	525	1.0	37.1	6370	C412_ 37.1 S3 M3LA4	123	C412_ 37.1 P100 BN100LA4	124
38	512	2.0	37.0	10000	C513_ 37.0 S3 M3LA4	126	C513_ 37.0 P100 BN100LA4	127
38	510	1.2	36.8	6390	C413_ 36.8 S3 M3LA4	123	C413_ 36.8 P100 BN100LA4	124
39	515	1.5	36.4	10000	C512_ 36.4 S3 M3LA4	126	C512_ 36.4 P100 BN100LA4	127
39	501	3.1	36.1	16000	C613_ 36.1 S3 M3LA4	129	C613_ 36.1 P100 BN100LA4	130
41	481	0.9	34.7	5240	C353_ 34.7 S3 M3LA4	120	C353_ 34.7 P100 BN100LA4	121
41	484	2.5	34.2	16000	C612_ 34.2 S3 M3LA4	129	C612_ 34.2 P100 BN100LA4	130
42	473	1.1	33.4	6290	C412_ 33.4 S3 M3LA4	123	C412_ 33.4 P100 BN100LA4	124
43	468	1.7	33.0	10000	C512_ 33.0 S3 M3LA4	126	C512_ 33.0 P100 BN100LA4	127
43	457	3.3	33.0	16000	C613_ 33.0 S3 M3LA4	129	C613_ 33.0 P100 BN100LA4	130
45	445	1.1	31.4	6290	C412_ 31.4 S3 M3LA4	123	C412_ 31.4 P100 BN100LA4	124
46	431	3.1	30.4	16000	C612_ 30.4 S3 M3LA4	129	C612_ 30.4 P100 BN100LA4	130
47	421	1.9	29.8	10000	C512_ 29.8 S3 M3LA4	126	C512_ 29.8 P100 BN100LA4	127
49	398	1.1	28.7	5220	C353_ 28.7 S3 M3LA4	120	C353_ 28.7 P100 BN100LA4	121
50	401	1.2	28.3	6190	C412_ 28.3 S3 M3LA4	123	C412_ 28.3 P100 BN100LA4	124
51	388	3.5	27.4	15900	C612_ 27.4 S3 M3LA4	129	C612_ 27.4 P100 BN100LA4	130
54	363	1.2	26.2	5140	C353_ 26.2 S3 M3LA4	120	C353_ 26.2 P100 BN100LA4	121
54	367	2.2	25.9	10000	C512_ 25.9 S3 M3LA4	126	C512_ 25.9 P100 BN100LA4	127
56	355	1.4	25.0	6120	C412_ 25.0 S3 M3LA4	123	C412_ 25.0 P100 BN100LA4	124
60	331	2.4	23.4	10000	C512_ 23.4 S3 M3LA4	126	C512_ 23.4 P100 BN100LA4	127
62	320	0.9	22.6	4220	C312_ 22.6 S3 M3LA4	117	C312_ 22.6 P100 BN100LA4	118

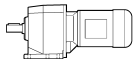

## 2.2 kW

$n_2$ min <sup>-1</sup>	$M_2$ Nm	S	i	$R_{n2}$ N				IEC	
63	319	1.6	22.6	6000	C412_ 22.6 S3 M3LA4	123	C412_ 22.6 P100 BN100LA4	124	
64	307	1.4	22.1	5060	C353_ 22.1 S3 M3LA4	120	C353_ 22.1 P100 BN100LA4	121	
66	301	1.0	14.0	4200	C312_ 14.0 S3 M3LC6	117	C312_ 14.0 P112 BN112M6	118	
67	297	2.7	21.0	10000	C512_ 21.0 S3 M3LA4	126	C512_ 21.0 P100 BN100LA4	127	
70	279	1.4	20.2	4970	C353_ 20.2 S3 M3LA4	120	C353_ 20.2 P100 BN100LA4	121	
70	284	1.0	20.1	4200	C312_ 20.1 S3 M3LA4	117	C312_ 20.1 P100 BN100LA4	118	
71	280	1.7	19.8	5890	C412_ 19.8 S3 M3LA4	123	C412_ 19.8 P100 BN100LA4	124	
74	269	1.4	19.0	4920	C352_ 19.0 S3 M3LA4	110	C352_ 19.0 P100 BN100LA4	121	
75	267	3.0	18.9	10000	C512_ 18.9 S3 M3LA4	126	C512_ 18.9 P100 BN100LA4	127	
78	256	1.1	18.1	4130	C312_ 18.1 S3 M3LA4	117	C312_ 18.1 P100 BN100LA4	118	
79	252	1.9	17.8	5760	C412_ 17.8 S3 M3LA4	123	C412_ 17.8 P100 BN100LA4	124	
82	242	1.6	17.1	4810	C352_ 17.1 S3 M3LA4	110	C352_ 17.1 P100 BN100LA4	121	
84	238	1.2	11.1	4090	C312_ 11.1 S3 M3LC6	117	C312_ 11.1 P112 BN112M6	118	
85	235	3.4	16.6	10000	C512_ 16.6 S3 M3LA4	126	C512_ 16.6 P100 BN100LA4	127	
89	224	2.0	15.8	5650	C412_ 15.8 S3 M3LA4	123	C412_ 15.8 P100 BN100LA4	124	
90	221	1.2	15.6	4060	C312_ 15.6 S3 M3LA4	117	C312_ 15.6 P100 BN100LA4	118	
96	209	1.8	14.8	4710	C352_ 14.8 S3 M3LA4	110	C352_ 14.8 P100 BN100LA4	121	
99	202	2.2	14.2	5510	C412_ 14.2 S3 M3LA4	123	C412_ 14.2 P100 BN100LA4	124	
100	199	1.3	14.0	3980	C312_ 14.0 S3 M3LA4	117	C312_ 14.0 P100 BN100LA4	118	
106	188	2.0	13.3	4590	C352_ 13.3 S3 M3LA4	110	C352_ 13.3 P100 BN100LA4	121	
114	175	2.4	12.4	5360	C412_ 12.4 S3 M3LA4	123	C412_ 12.4 P100 BN100LA4	124	
114	176	0.9	12.4	2270	C212_ 12.4 S3 M3LA4	114	C212_ 12.4 P100 BN100LA4	115	
114	174	1.4	12.3	3900	C312_ 12.3 S3 M3LA4	117	C312_ 12.3 P100 BN100LA4	118	
121	165	2.3	11.7	4490	C352_ 11.7 S3 M3LA4	110	C352_ 11.7 P100 BN100LA4	121	
126	158	1.0	11.2	2250	C212_ 11.2 S3 M3LA4	114	C212_ 11.2 P100 BN100LA4	115	
126	158	2.7	11.2	5220	C412_ 11.2 S3 M3LA4	123	C412_ 11.2 P100 BN100LA4	124	
127	157	1.5	11.1	3820	C312_ 11.1 S3 M3LA4	117	C312_ 11.1 P100 BN100LA4	118	
130	154	1.5	7.2	3810	C312_ 7.2 S3 M3LC6	117	C312_ 7.2 P112 BN112M6	118	
131	152	1.0	7.1	2260	C212_ 7.1 S3 M3LC6	114	C212_ 7.1 P112 BN112M6	115	
134	149	2.6	10.5	4370	C352_ 10.5 S3 M3LA4	110	C352_ 10.5 P100 BN100LA4	121	
146	137	1.1	9.6	2250	C212_ 9.6 S3 M3LA4	114	C212_ 9.6 P100 BN100LA4	115	
147	136	2.9	9.6	5050	C412_ 9.6 S3 M3LA4	123	C412_ 9.6 P100 BN100LA4	124	
152	132	1.7	9.3	3690	C312_ 9.3 S3 M3LA4	117	C312_ 9.3 P100 BN100LA4	118	
160	125	3.1	8.8	4210	C352_ 8.8 S3 M3LA4	110	C352_ 8.8 P100 BN100LA4	121	
162	123	1.1	8.7	2220	C212_ 8.7 S3 M3LA4	114	C212_ 8.7 P100 BN100LA4	115	
168	118	1.8	8.4	3600	C312_ 8.4 S3 M3LA4	117	C312_ 8.4 P100 BN100LA4	118	
177	113	1.2	15.8	2210	C212_ 15.8 S3 M3SA2	114	C212_ 15.8 P90 BN90L2	115	
178	112	3.4	7.9	4090	C352_ 7.9 S3 M3LA4	110	C352_ 7.9 P100 BN100LA4	121	
188	106	1.5	5.0	3410	C312_ 5.0 S3 M3LC6	117	C312_ 5.0 P112 BN112M6	118	
197	101	2.0	7.2	3480	C312_ 7.2 S3 M3LA4	117	C312_ 7.2 P100 BN100LA4	118	
199	100	1.3	7.1	2180	C212_ 7.1 S3 M3LA4	114	C212_ 7.1 P100 BN100LA4	115	
219	91	2.1	6.5	3390	C312_ 6.5 S3 M3LA4	117	C312_ 6.5 P100 BN100LA4	118	
221	90	1.4	6.4	2140	C212_ 6.4 S3 M3LA4	114	C212_ 6.4 P100 BN100LA4	115	
232	86	1.2	6.1	2040	C212_ 6.1 S3 M3LA4	114	C212_ 6.1 P100 BN100LA4	115	
241	83	2.4	5.8	3710	C352_ 5.8 S3 M3LA4	110	C352_ 5.8 P100 BN100LA4	121	
285	70	2.2	5.0	3100	C312_ 5.0 S3 M3LA4	117	C312_ 5.0 P100 BN100LA4	118	
296	68	1.5	4.8	1970	C212_ 4.8 S3 M3LA4	114	C212_ 4.8 P100 BN100LA4	115	
302	66	2.7	9.3	3130	C312_ 9.3 S3 M3SA2	117	C312_ 9.3 P90 BN90L2	118	
305	65	3.1	4.6	3490	C352_ 4.6 S3 M3LA4	110	C352_ 4.6 P100 BN100LA4	121	
324	62	1.8	8.7	2000	C212_ 8.7 S3 M3SA2	114	C212_ 8.7 P90 BN90L2	115	
336	59	2.9	8.4	3040	C312_ 8.4 S3 M3SA2	117	C312_ 8.4 P90 BN90L2	118	
346	58	3.5	2.7	3380	C352_ 2.7 S3 M3LC6	110	C352_ 2.7 P112 BN112M6	121	
369	54	0.8	7.6	930	C112_ 7.6 S3 M3SA2	111	C112_ 7.6 P90 BN90L2	112	
377	53	2.8	3.7	2890	C312_ 3.7 S3 M3LA4	117	C312_ 3.7 P100 BN100LA4	118	
380	52	1.7	3.7	1890	C212_ 3.7 S3 M3LA4	114	C212_ 3.7 P100 BN100LA4	115	
392	51	3.1	7.2	2920	C312_ 7.2 S3 M3SA2	117	C312_ 7.2 P90 BN90L2	118	
397	50	2.1	7.1	1920	C212_ 7.1 S3 M3SA2	114	C212_ 7.1 P90 BN90L2	115	
409	49	0.9	6.9	990	C112_ 6.9 S3 M3SA2	111	C112_ 6.9 P90 BN90L2	112	
436	46	3.4	6.5	2830	C312_ 6.5 S3 M3SA2	117	C312_ 6.5 P90 BN90L2	118	
441	45	2.2	6.4	1870	C212_ 6.4 S3 M3SA2	114	C212_ 6.4 P90 BN90L2	115	
449	44	3.4	6.3	2760	C312_ 6.3 S3 M3SA2	117	C312_ 6.3 P90 BN90L2	118	
462	43	2.0	6.1	1820	C212_ 6.1 S3 M3SA2	114	C212_ 6.1 P90 BN90L2	115	
490	41	3.2	2.9	2700	C312_ 2.9 S3 M3LA4	117	C312_ 2.9 P100 BN100LA4	118	
510	39	0.9	2.8	690	C112_ 2.8 S3 M3LA4	111	C112_ 2.8 P100 BN100LA4	112	
518	39	2.1	2.7	1770	C212_ 2.7 S3 M3LA4	114	C212_ 2.7 P100 BN100LA4	115	

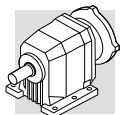

## 2.2 kW



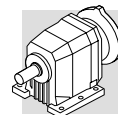

n <sub>2</sub> min <sup>-1</sup>	M <sub>2</sub> Nm	S	i	R <sub>n2</sub> N				
589	34	2.4	4.8	1720	C212_ 4.8 S3 M3SA2	114	C212_ 4.8 P90 BN90L2	115
758	26	2.7	3.7	1620	C212_ 3.7 S3 M3SA2	114	C212_ 3.7 P90 BN90L2	115
770	26	1.3	3.7	970	C112_ 3.7 S3 M3SA2	111	C112_ 3.7 P90 BN90L2	112
1015	20	1.5	2.8	920	C112_ 2.8 S3 M3SA2	111	C112_ 2.8 P90 BN90L2	112
1032	19	3.4	2.7	1490	C212_ 2.7 S3 M3SA2	114	C212_ 2.7 P90 BN90L2	115

## 3 kW

2.0	13319	0.9	720.3	85000	C1004_ 720.3 S3 M3LB4	141	C1004_ 720.3 P100 BN100LB4	142
2.4	10773	1.1	582.6	85000	C1004_ 582.6 S3 M3LB4	141	C1004_ 582.6 P100 BN100LB4	142
3.4	7747	0.9	419.0	60000	C904_ 419.0 S3 M3LB4	138	C904_ 419.0 P100 BN100LB4	139
3.4	7577	1.6	409.8	85000	C1004_ 409.8 S3 M3LB4	141	C1004_ 409.8 P100 BN100LB4	142
4.2	6268	1.1	339.0	60000	C904_ 339.0 S3 M3LB4	138	C904_ 339.0 P100 BN100LB4	139
4.4	5984	2.0	323.6	85000	C1004_ 323.6 S3 M3LB4	141	C1004_ 323.6 P100 BN100LB4	142
5.3	4965	1.5	268.5	60000	C904_ 268.5 S3 M3LB4	138	C904_ 268.5 P100 BN100LB4	139
5.4	4863	2.5	263.0	85000	C1004_ 263.0 S3 M3LB4	141	C1004_ 263.0 P100 BN100LB4	142
6.5	4079	1.0	215.8	35000	C803_ 215.8 S3 M3LB4	135	C803_ 215.8 P100 BN100LB4	136
6.6	3927	1.8	212.4	60000	C904_ 212.4 S3 M3LB4	138	C904_ 212.4 P100 BN100LB4	139
7.1	3739	1.0	197.9	35000	C803_ 197.9 S3 M3LB4	135	C803_ 197.9 P100 BN100LB4	136
8.2	3252	2.2	172.1	60000	C903_ 172.1 S3 M3LB4	138	C903_ 172.1 P100 BN100LB4	139
8.3	3193	1.3	169.0	35000	C803_ 169.0 S3 M3LB4	135	C803_ 169.0 P100 BN100LB4	136
9.5	2818	1.4	149.1	35000	C803_ 149.1 S3 M3LB4	135	C803_ 149.1 P100 BN100LB4	136
9.6	2765	2.6	146.3	60000	C903_ 146.3 S3 M3LB4	138	C903_ 146.3 P100 BN100LB4	139
10.5	2535	2.8	134.1	60000	C903_ 134.1 S3 M3LB4	138	C903_ 134.1 P100 BN100LB4	139
12.1	2206	3.3	116.7	60000	C903_ 116.7 S3 M3LB4	138	C903_ 116.7 P100 BN100LB4	139
12.5	2125	1.1	112.4	25000	C703_ 112.4 S3 M3LB4	132	C703_ 112.4 P100 BN100LB4	133
12.9	2069	1.9	109.5	35000	C803_ 109.5 S3 M3LB4	135	C803_ 109.5 P100 BN100LB4	136
13.6	1961	1.2	103.8	25000	C703_ 103.8 S3 M3LB4	132	C703_ 103.8 P100 BN100LB4	133
14.5	1840	2.2	97.4	35000	C803_ 97.4 S3 M3LB4	135	C803_ 97.4 P100 BN100LB4	136
15.5	1720	0.9	91.0	16000	C613_ 91.0 S3 M3LB4	129	C613_ 91.0 P100 BN100LB4	130
15.8	1687	2.4	89.3	35000	C803_ 89.3 S3 M3LB4	135	C803_ 89.3 P100 BN100LB4	136
16.0	1667	1.4	88.2	25000	C703_ 88.2 S3 M3LB4	132	C703_ 88.2 P100 BN100LB4	133
17.0	1569	1.0	83.0	16000	C613_ 83.0 S3 M3LB4	129	C613_ 83.0 P100 BN100LB4	130
17.3	1538	1.5	81.4	25000	C703_ 81.4 S3 M3LB4	132	C703_ 81.4 P100 BN100LB4	133
18.3	1453	2.8	76.9	35000	C803_ 76.9 S3 M3LB4	135	C803_ 76.9 P100 BN100LB4	136
19.0	1402	1.1	74.2	16000	C613_ 74.2 S3 M3LB4	129	C613_ 74.2 P100 BN100LB4	130
19.8	1348	1.7	71.3	25000	C703_ 71.3 S3 M3LB4	132	C703_ 71.3 P100 BN100LB4	133
20.0	1332	3.0	70.5	35000	C803_ 70.5 S3 M3LB4	135	C803_ 70.5 P100 BN100LB4	136
20.8	1279	1.3	67.7	16000	C613_ 67.7 S3 M3LB4	129	C613_ 67.7 P100 BN100LB4	130
24.1	1107	1.4	58.6	16000	C613_ 58.6 S3 M3LB4	129	C613_ 58.6 P100 BN100LB4	130
25.0	1068	2.2	56.5	25000	C703_ 56.5 S3 M3LB4	132	C703_ 56.5 P100 BN100LB4	133
26.4	1010	1.6	53.5	16000	C613_ 53.5 S3 M3LB4	129	C613_ 53.5 P100 BN100LB4	130
27.6	967	1.0	51.2	10000	C513_ 51.2 S3 M3LB4	126	C513_ 51.2 P100 BN100LB4	127
29.6	900	1.8	47.6	16000	C613_ 47.6 S3 M3LB4	129	C613_ 47.6 P100 BN100LB4	130
30	883	1.1	46.7	10000	C513_ 46.7 S3 M3LB4	126	C513_ 46.7 P100 BN100LB4	127
32	845	2.7	44.7	25000	C703_ 44.7 S3 M3LB4	132	C703_ 44.7 P100 BN100LB4	133
32	821	1.9	43.4	16000	C613_ 43.4 S3 M3LB4	129	C613_ 43.4 P100 BN100LB4	130
33	832	0.9	43.1	10000	C512_ 43.1 S3 M3LB4	126	C512_ 43.1 P100 BN100LB4	127
34	780	2.9	41.3	25000	C703_ 41.3 S3 M3LB4	132	C703_ 41.3 P100 BN100LB4	133
35	765	1.3	40.5	10000	C513_ 40.5 S3 M3LB4	126	C513_ 40.5 P100 BN100LB4	127
35	779	1.0	40.4	10000	C512_ 40.4 S3 M3LB4	126	C512_ 40.4 P100 BN100LB4	127
37	734	1.8	38.0	16000	C612_ 38.0 S3 M3LB4	129	C612_ 38.0 P100 BN100LB4	130
38	698	1.4	37.0	10000	C513_ 37.0 S3 M3LB4	126	C513_ 37.0 P100 BN100LB4	127
39	702	1.1	36.4	10000	C512_ 36.4 S3 M3LB4	126	C512_ 36.4 P100 BN100LB4	127
39	683	2.3	36.1	16000	C613_ 36.1 S3 M3LB4	129	C613_ 36.1 P100 BN100LB4	130
41	661	1.9	34.2	16000	C612_ 34.2 S3 M3LB4	129	C612_ 34.2 P100 BN100LB4	130
43	638	1.2	33.0	10000	C512_ 33.0 S3 M3LB4	126	C512_ 33.0 P100 BN100LB4	127
43	623	2.4	33.0	16000	C613_ 33.0 S3 M3LB4	129	C613_ 33.0 P100 BN100LB4	130
45	590	1.0	31.2	5550	C413_ 31.2 S3 M3LB4	123	C413_ 31.2 P100 BN100LB4	124
46	588	2.3	30.4	15900	C612_ 30.4 S3 M3LB4	129	C612_ 30.4 P100 BN100LB4	130
47	575	1.4	29.8	10000	C512_ 29.8 S3 M3LB4	126	C512_ 29.8 P100 BN100LB4	127
50	546	0.9	28.3	5460	C412_ 28.3 S3 M3LB4	123	C412_ 28.3 P100 BN100LB4	124

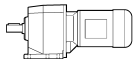



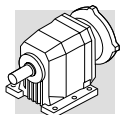

## 3 kW

$n_2$ min <sup>-1</sup>	$M_2$ Nm	S	i	$R_{n2}$ N				
51	519	1.9	27.4	10000	C513_ 27.4 S3 M3LB4	126	C513_ 27.4 P100 BN100LB4	127
51	529	2.6	27.4	15400	C612_ 27.4 S3 M3LB4	129	C612_ 27.4 P100 BN100LB4	130
54	494	0.9	26.2	4500	C353_ 26.2 S3 M3LB4	120	C353_ 26.2 P100 BN100LB4	121
54	500	1.6	25.9	10000	C512_ 25.9 S3 M3LB4	126	C512_ 25.9 P100 BN100LB4	127
56	483	1.0	25.0	5480	C412_ 25.0 S3 M3LB4	123	C412_ 25.0 P100 BN100LB4	124
57	479	2.8	24.8	15100	C612_ 24.8 S3 M3LB4	129	C612_ 24.8 P100 BN100LB4	130
59	451	2.0	23.9	10000	C513_ 23.9 S3 M3LB4	126	C513_ 23.9 P100 BN100LB4	127
60	451	1.8	23.4	10000	C512_ 23.4 S3 M3LB4	126	C512_ 23.4 P100 BN100LB4	127
63	435	1.1	22.6	5420	C412_ 22.6 S3 M3LB4	123	C412_ 22.6 P100 BN100LB4	124
63	431	3.1	22.4	14600	C612_ 22.4 S3 M3LB4	129	C612_ 22.4 P100 BN100LB4	130
64	418	1.0	22.1	4530	C353_ 22.1 S3 M3LB4	120	C353_ 22.1 P100 BN100LB4	121
65	412	2.2	21.8	10000	C513_ 21.8 S3 M3LB4	126	C513_ 21.8 P100 BN100LB4	127
67	405	2.0	21.0	10000	C512_ 21.0 S3 M3LB4	126	C512_ 21.0 P100 BN100LB4	127
70	381	1.0	20.2	4480	C353_ 20.2 S3 M3LB4	120	C353_ 20.2 P100 BN100LB4	121
71	381	1.3	19.8	5390	C412_ 19.8 S3 M3LB4	123	C412_ 19.8 P100 BN100LB4	124
74	367	1.0	19.0	4450	C352_ 19.0 S3 M3LB4	110	C352_ 19.0 P100 BN100LB4	121
75	365	2.2	18.9	10000	C512_ 18.9 S3 M3LB4	126	C512_ 18.9 P100 BN100LB4	127
79	343	1.4	17.8	5300	C412_ 17.8 S3 M3LB4	123	C412_ 17.8 P100 BN100LB4	124
82	330	1.2	17.1	4380	C352_ 17.1 S3 M3LB4	110	C352_ 17.1 P100 BN100LB4	121
85	320	2.5	16.6	9790	C512_ 16.6 S3 M3LB4	126	C512_ 16.6 P100 BN100LB4	127
89	305	1.5	15.8	5240	C412_ 15.8 S3 M3LB4	123	C412_ 15.8 P100 BN100LB4	124
94	289	2.8	15.0	9540	C512_ 15.0 S3 M3LB4	126	C512_ 15.0 P100 BN100LB4	127
96	285	1.3	14.8	4340	C352_ 14.8 S3 M3LB4	110	C352_ 14.8 P100 BN100LB4	121
99	275	1.6	14.2	5140	C412_ 14.2 S3 M3LB4	123	C412_ 14.2 P100 BN100LB4	124
100	271	1.0	14.0	3610	C312_ 14.0 S3 M3LB4	117	C312_ 14.0 P100 BN100LB4	118
106	256	1.5	13.3	4260	C352_ 13.3 S3 M3LB4	110	C352_ 13.3 P100 BN100LB4	121
107	253	3.0	13.1	9200	C512_ 13.1 S3 M3LB4	126	C512_ 13.1 P100 BN100LB4	127
114	239	1.8	12.4	5040	C412_ 12.4 S3 M3LB4	123	C412_ 12.4 P100 BN100LB4	124
114	238	1.0	12.3	3580	C312_ 12.3 S3 M3LB4	117	C312_ 12.3 P100 BN100LB4	118
119	228	3.4	11.8	8950	C512_ 11.8 S3 M3LB4	126	C512_ 11.8 P100 BN100LB4	127
121	225	1.7	11.7	4200	C352_ 11.7 S3 M3LB4	110	C352_ 11.7 P100 BN100LB4	121
126	215	1.9	11.2	4930	C412_ 11.2 S3 M3LB4	123	C412_ 11.2 P100 BN100LB4	124
127	214	1.1	11.1	3520	C312_ 11.1 S3 M3LB4	117	C312_ 11.1 P100 BN100LB4	118
134	203	1.9	10.5	4110	C352_ 10.5 S3 M3LB4	110	C352_ 10.5 P100 BN100LB4	121
142	191	1.2	20.1	3480	C312_ 20.1 S3 M3LA2	117	C312_ 20.1 P100 BN100L2	118
147	185	2.1	9.6	4800	C412_ 9.6 S3 M3LB4	123	C412_ 9.6 P100 BN100LB4	124
152	179	1.2	9.3	3450	C312_ 9.3 S3 M3LB4	117	C312_ 9.3 P100 BN100LB4	118
160	170	2.2	8.8	3990	C352_ 8.8 S3 M3LB4	110	C352_ 8.8 P100 BN100LB4	121
168	162	1.3	8.4	3380	C312_ 8.4 S3 M3LB4	117	C312_ 8.4 P100 BN100LB4	118
178	153	2.5	7.9	3890	C352_ 7.9 S3 M3LB4	110	C352_ 7.9 P100 BN100LB4	121
181	151	0.9	15.8	1940	C212_ 15.8 S3 M3LA2	114	C212_ 15.8 P100 BN100L2	115
183	148	1.4	15.6	3340	C312_ 15.6 S3 M3LA2	117	C312_ 15.6 P100 BN100L2	118
197	138	1.4	7.2	3300	C312_ 7.2 S3 M3LB4	117	C312_ 7.2 P100 BN100LB4	118
199	137	1.0	7.1	1940	C212_ 7.1 S3 M3LB4	114	C212_ 7.1 P100 BN100LB4	115
200	136	2.6	7.1	4490	C412_ 7.1 S3 M3LB4	123	C412_ 7.1 P100 BN100LB4	124
208	131	2.7	6.8	3780	C352_ 6.8 S3 M3LB4	110	C352_ 6.8 P100 BN100LB4	121
219	125	1.6	6.5	3220	C312_ 6.5 S3 M3LB4	117	C312_ 6.5 P100 BN100LB4	118
221	123	1.0	6.4	1920	C212_ 6.4 S3 M3LB4	114	C212_ 6.4 P100 BN100LB4	115
222	123	2.8	6.4	4370	C412_ 6.4 S3 M3LB4	123	C412_ 6.4 P100 BN100LB4	124
231	118	2.9	6.1	3680	C352_ 6.1 S3 M3LB4	110	C352_ 6.1 P100 BN100LB4	121
232	117	1.7	12.3	3190	C312_ 12.3 S3 M3LA2	117	C312_ 12.3 P100 BN100L2	118
237	115	2.3	6.0	4090	C412_ 6.0 S3 M3LB4	123	C412_ 6.0 P100 BN100LB4	124
241	113	1.8	5.8	3530	C352_ 5.8 S3 M3LB4	110	C352_ 5.8 P100 BN100LB4	121
256	106	1.2	11.2	1900	C212_ 11.2 S3 M3LA2	114	C212_ 11.2 P100 BN100L2	115
258	106	1.8	11.1	3110	C312_ 11.1 S3 M3LA2	117	C312_ 11.1 P100 BN100L2	118
285	96	1.6	5.0	2950	C312_ 5.0 S3 M3LB4	117	C312_ 5.0 P100 BN100LB4	118
296	92	1.1	4.8	1780	C212_ 4.8 S3 M3LB4	114	C212_ 4.8 P100 BN100LB4	115
302	90	2.9	4.7	3880	C412_ 4.7 S3 M3LB4	123	C412_ 4.7 P100 BN100LB4	124
308	88	2.0	9.3	2990	C312_ 9.3 S3 M3LA2	117	C312_ 9.3 P100 BN100L2	118
329	83	1.3	8.7	1850	C212_ 8.7 S3 M3LA2	114	C212_ 8.7 P100 BN100L2	115
342	80	2.1	8.4	2910	C312_ 8.4 S3 M3LA2	117	C312_ 8.4 P100 BN100L2	118
377	72	2.1	3.7	2780	C312_ 3.7 S3 M3LB4	117	C312_ 3.7 P100 BN100LB4	118
380	72	1.3	3.7	1740	C212_ 3.7 S3 M3LB4	114	C212_ 3.7 P100 BN100LB4	115
399	68	2.3	7.2	2810	C312_ 7.2 S3 M3LA2	117	C312_ 7.2 P100 BN100L2	118
404	67	1.6	7.1	1800	C212_ 7.1 S3 M3LA2	114	C212_ 7.1 P100 BN100L2	115

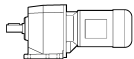

## 3 kW



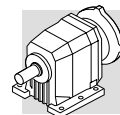

$n_2$ min <sup>-1</sup>	$M_2$ Nm	S	i	$R_{n2}$ N				
404	67	3.0	3.5	3130	C352_ 3.5 S3 M3LB4	110	C352_ 3.5 P100 BN100LB4	121
443	61	2.5	6.5	2730	C312_ 6.5 S3 M3LA2	117	C312_ 6.5 P100 BN100L2	118
448	61	1.6	6.4	1760	C212_ 6.4 S3 M3LA2	114	C212_ 6.4 P100 BN100L2	115
457	60	2.5	6.3	2650	C312_ 6.3 S3 M3LA2	117	C312_ 6.3 P100 BN100L2	118
470	58	1.5	6.1	1690	C212_ 6.1 S3 M3LA2	114	C212_ 6.1 P100 BN100L2	115
490	56	2.3	2.9	2610	C312_ 2.9 S3 M3LB4	117	C312_ 2.9 P100 BN100LB4	118
518	53	1.5	2.7	1660	C212_ 2.7 S3 M3LB4	114	C212_ 2.7 P100 BN100LB4	115
578	47	2.9	5.0	2500	C312_ 5.0 S3 M3LA2	117	C312_ 5.0 P100 BN100L2	118
600	45	1.8	4.8	1620	C212_ 4.8 S3 M3LA2	114	C212_ 4.8 P100 BN100L2	115
766	36	3.4	3.7	2320	C312_ 3.7 S3 M3LA2	117	C312_ 3.7 P100 BN100L2	118
771	35	2.0	3.7	1540	C212_ 3.7 S3 M3LA2	114	C212_ 3.7 P100 BN100L2	115
783	35	1.0	3.7	560	C112_ 3.7 S3 M3LA2	111	C112_ 3.7 P100 BN100L2	112
1033	26	1.1	2.8	750	C112_ 2.8 S3 M3LA2	111	C112_ 2.8 P100 BN100L2	112
1051	26	2.5	2.7	1430	C212_ 2.7 S3 M3LA2	114	C212_ 2.7 P100 BN100L2	115

## 4 kW

2.8	12569	1.0	502.6	85000	C1004_ 502.6 S3 M3LC4	141	C1004_ 502.6 P112 BN112M4	142
3.4	10249	1.2	409.8	85000	C1004_ 409.8 S3 M3LC4	141	C1004_ 409.8 P112 BN112M4	142
4.3	8093	1.5	323.6	85000	C1004_ 323.6 S3 M3LC4	141	C1004_ 323.6 P112 BN112M4	142
4.7	7325	1.0	292.9	60000	C904_ 292.9 S3 M3LC4	138	C904_ 292.9 P112 BN112M4	139
5.2	6715	1.1	268.5	60000	C904_ 268.5 S3 M3LC4	138	C904_ 268.5 P112 BN112M4	139
5.7	6107	2.0	244.2	85000	C1004_ 244.2 S3 M3LC4	141	C1004_ 244.2 P112 BN112M4	142
6.0	5795	1.2	231.7	60000	C904_ 231.7 S3 M3LC4	138	C904_ 231.7 P112 BN112M4	139
7.5	4637	2.6	185.4	85000	C1004_ 185.4 S3 M3LC4	141	C1004_ 185.4 P112 BN112M4	142
8.1	4399	1.6	172.1	60000	C903_ 172.1 S3 M3LC4	138	C903_ 172.1 P112 BN112M4	139
8.2	4319	0.9	169.0	35000	C803_ 169.0 S3 M3LC4	135	C803_ 169.0 P112 BN112M4	136
10.2	3493	1.1	136.7	35000	C803_ 136.7 S3 M3LC4	135	C803_ 136.7 P112 BN112M4	136
10.4	3428	2.1	134.1	60000	C903_ 134.1 S3 M3LC4	138	C903_ 134.1 P112 BN112M4	139
11.9	2983	2.4	116.7	60000	C903_ 116.7 S3 M3LC4	138	C903_ 116.7 P112 BN112M4	139
12.7	2799	1.4	109.5	35000	C803_ 109.5 S3 M3LC4	135	C803_ 109.5 P112 BN112M4	136
14.3	2489	1.6	97.4	35000	C803_ 97.4 S3 M3LC4	135	C803_ 97.4 P112 BN112M4	136
14.4	2460	2.9	96.2	60000	C903_ 96.2 S3 M3LC4	138	C903_ 96.2 P112 BN112M4	139
15.6	2282	1.8	89.3	35000	C803_ 89.3 S3 M3LC4	135	C803_ 89.3 P112 BN112M4	136
15.8	2254	1.0	88.2	25000	C703_ 88.2 S3 M3LC4	132	C703_ 88.2 P112 BN112M4	133
17.1	2081	1.1	81.4	25000	C703_ 81.4 S3 M3LC4	132	C703_ 81.4 P112 BN112M4	133
19.5	1823	1.3	71.3	25000	C703_ 71.3 S3 M3LC4	132	C703_ 71.3 P112 BN112M4	133
19.7	1802	2.2	70.5	35000	C803_ 70.5 S3 M3LC4	135	C803_ 70.5 P112 BN112M4	136
20.5	1730	0.9	67.7	16000	C613_ 67.7 S3 M3LC4	129	C613_ 67.7 P112 BN112M4	130
23.7	1498	1.1	58.6	16000	C613_ 58.6 S3 M3LC4	129	C613_ 58.6 P112 BN112M4	130
24.3	1464	2.7	57.3	35000	C803_ 57.3 S3 M3LC4	135	C803_ 57.3 P112 BN112M4	136
24.6	1444	1.6	56.5	25000	C703_ 56.5 S3 M3LC4	132	C703_ 56.5 P112 BN112M4	133
26.0	1366	1.2	53.5	16000	C613_ 53.5 S3 M3LC4	129	C613_ 53.5 P112 BN112M4	130
26.6	1333	1.7	52.2	25000	C703_ 52.2 S3 M3LC4	132	C703_ 52.2 P112 BN112M4	133
29.2	1217	1.3	47.6	16000	C613_ 47.6 S3 M3LC4	129	C613_ 47.6 P112 BN112M4	130
29.3	1213	3.1	47.4	35000	C803_ 47.4 S3 M3LC4	135	C803_ 47.4 P112 BN112M4	136
31	1142	2.0	44.7	25000	C703_ 44.7 S3 M3LC4	132	C703_ 44.7 P112 BN112M4	133
32	1112	3.4	43.5	35000	C803_ 43.5 S3 M3LC4	135	C803_ 43.5 P112 BN112M4	136
32	1110	1.4	43.4	16000	C613_ 43.4 S3 M3LC4	129	C613_ 43.4 P112 BN112M4	130
34	1055	2.2	41.3	25000	C703_ 41.3 S3 M3LC4	132	C703_ 41.3 P112 BN112M4	133
34	1035	1.0	40.5	10000	C513_ 40.5 S3 M3LC4	126	C513_ 40.5 P112 BN112M4	127
37	992	1.4	38.0	16000	C612_ 38.0 S3 M3LC4	129	C612_ 38.0 P112 BN112M4	130
38	945	1.1	37.0	10000	C513_ 37.0 S3 M3LC4	126	C513_ 37.0 P112 BN112M4	127
40	907	2.3	34.7	23400	C702_ 34.7 S3 M3LC4	132	C702_ 34.7 P112 BN112M4	133
41	893	1.4	34.2	15700	C612_ 34.2 S3 M3LC4	129	C612_ 34.2 P112 BN112M4	130
42	862	0.9	33.0	10000	C512_ 33.0 S3 M3LC4	126	C512_ 33.0 P112 BN112M4	127
46	795	1.7	30.4	15300	C612_ 30.4 S3 M3LC4	129	C612_ 30.4 P112 BN112M4	130
47	777	1.0	29.8	10000	C512_ 29.8 S3 M3LC4	126	C512_ 29.8 P112 BN112M4	127
50	724	2.9	27.7	22300	C702_ 27.7 S3 M3LC4	132	C702_ 27.7 P112 BN112M4	133
51	716	1.9	27.4	14900	C612_ 27.4 S3 M3LC4	129	C612_ 27.4 P112 BN112M4	130
54	676	1.2	25.9	10000	C512_ 25.9 S3 M3LC4	126	C512_ 25.9 P112 BN112M4	127

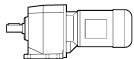



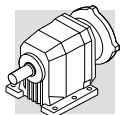

## 4 kW

$n_2$ min <sup>-1</sup>	$M_2$ Nm	S	i	$R_{n2}$ N			 IEC	
56	648	2.1	24.8	14600	C612_ 24.8 S3 M3LC4	129	C612_ 24.8 P112 BN112M4	130
60	610	1.3	23.4	10000	C512_ 23.4 S3 M3LC4	126	C512_ 23.4 P112 BN112M4	127
62	584	2.3	22.4	14200	C612_ 22.4 S3 M3LC4	129	C612_ 22.4 P112 BN112M4	130
66	547	1.5	21.0	9920	C512_ 21.0 S3 M3LC4	126	C512_ 21.0 P112 BN112M4	127
70	516	0.9	19.8	4760	C412_ 19.8 S3 M3LC4	123	C412_ 19.8 P112 BN112M4	124
71	512	2.6	19.6	13800	C612_ 19.6 S3 M3LC4	129	C612_ 19.6 P112 BN112M4	130
74	493	1.6	18.9	9730	C512_ 18.9 S3 M3LC4	126	C512_ 18.9 P112 BN112M4	127
78	465	1.0	17.8	4720	C412_ 17.8 S3 M3LC4	123	C412_ 17.8 P112 BN112M4	124
79	461	2.9	17.7	13400	C612_ 17.7 S3 M3LC4	129	C612_ 17.7 P112 BN112M4	130
84	433	1.8	16.6	9440	C512_ 16.6 S3 M3LC4	126	C512_ 16.6 P112 BN112M4	127
87	416	3.2	15.9	13100	C612_ 15.9 S3 M3LC4	129	C612_ 15.9 P112 BN112M4	130
88	413	1.1	15.8	4740	C412_ 15.8 S3 M3LC4	123	C412_ 15.8 P112 BN112M4	124
93	391	2.0	15.0	9230	C512_ 15.0 S3 M3LC4	126	C512_ 15.0 P112 BN112M4	127
94	385	1.0	14.8	3880	C352_ 14.8 S3 M3LC4	110	C352_ 14.8 P112 BN112M4	121
98	372	1.2	14.2	4690	C412_ 14.2 S3 M3LC4	123	C412_ 14.2 P112 BN112M4	124
105	346	1.1	13.3	3840	C352_ 13.3 S3 M3LC4	110	C352_ 13.3 P112 BN112M4	121
106	343	2.2	13.1	8930	C512_ 13.1 S3 M3LC4	126	C512_ 13.1 P112 BN112M4	127
112	324	1.3	12.4	4660	C412_ 12.4 S3 M3LC4	123	C412_ 12.4 P112 BN112M4	124
117	309	2.5	11.8	8720	C512_ 11.8 S3 M3LC4	126	C512_ 11.8 P112 BN112M4	127
119	305	1.2	11.7	3840	C352_ 11.7 S3 M3LC4	110	C352_ 11.7 P112 BN112M4	121
125	291	1.4	11.2	4580	C412_ 11.2 S3 M3LC4	123	C412_ 11.2 P112 BN112M4	124
132	274	1.4	10.5	3780	C352_ 10.5 S3 M3LC4	110	C352_ 10.5 P112 BN112M4	121
143	255	2.7	9.8	8290	C512_ 9.8 S3 M3LC4	126	C512_ 9.8 P112 BN112M4	127
145	251	1.6	9.6	4510	C412_ 9.6 S3 M3LC4	123	C412_ 9.6 P112 BN112M4	124
150	243	0.9	9.3	3150	C312_ 9.3 S3 M3LC4	117	C312_ 9.3 P112 BN112M4	118
158	230	1.7	8.8	3720	C352_ 8.8 S3 M3LC4	110	C352_ 8.8 P112 BN112M4	121
158	229	3.0	8.8	8070	C512_ 8.8 S3 M3LC4	126	C512_ 8.8 P112 BN112M4	127
161	226	1.7	8.6	4420	C412_ 8.6 S3 M3LC4	123	C412_ 8.6 P112 BN112M4	124
166	219	1.0	8.4	3110	C312_ 8.4 S3 M3LC4	117	C312_ 8.4 P112 BN112M4	118
176	207	1.8	7.9	3650	C352_ 7.9 S3 M3LC4	110	C352_ 7.9 P112 BN112M4	121
179	202	3.2	7.8	7800	C512_ 7.8 S3 M3LC4	126	C512_ 7.8 P112 BN112M4	127
184	197	1.1	15.6	3090	C312_ 15.6 S3 M3LB2	117	C312_ 15.6 P112 BN112M2	118
194	187	1.1	7.2	3070	C312_ 7.2 S3 M3LC4	117	C312_ 7.2 P112 BN112M4	118
197	184	1.9	7.1	4280	C412_ 7.1 S3 M3LC4	123	C412_ 7.1 P112 BN112M4	124
199	182	3.5	7.0	7580	C512_ 7.0 S3 M3LC4	126	C512_ 7.0 P112 BN112M4	127
204	177	1.2	14.0	3030	C312_ 14.0 S3 M3LB2	117	C312_ 14.0 P112 BN112M2	118
205	177	2.0	6.8	3580	C352_ 6.8 S3 M3LC4	110	C352_ 6.8 P112 BN112M4	121
215	168	1.2	6.5	3010	C312_ 6.5 S3 M3LC4	117	C312_ 6.5 P112 BN112M4	118
218	166	2.1	6.4	4180	C412_ 6.4 S3 M3LC4	123	C412_ 6.4 P112 BN112M4	124
222	164	0.9	6.3	2840	C312_ 6.3 S3 M3LC4	117	C312_ 6.3 P112 BN112M4	118
228	159	2.2	6.1	3500	C352_ 6.1 S3 M3LC4	110	C352_ 6.1 P112 BN112M4	121
233	156	1.3	12.3	2990	C312_ 12.3 S3 M3LB2	117	C312_ 12.3 P112 BN112M2	118
234	155	1.7	6.0	3840	C412_ 6.0 S3 M3LC4	123	C412_ 6.0 P112 BN112M4	124
238	153	1.3	5.8	3310	C352_ 5.8 S3 M3LC4	110	C352_ 5.8 P112 BN112M4	121
247	147	3.0	5.6	7020	C512_ 5.6 S3 M3LC4	126	C512_ 5.6 P112 BN112M4	127
259	140	1.4	11.1	2930	C312_ 11.1 S3 M3LB2	117	C312_ 11.1 P112 BN112M2	118
281	129	1.2	5.0	2760	C312_ 5.0 S3 M3LC4	117	C312_ 5.0 P112 BN112M4	118
298	122	0.9	9.6	1680	C212_ 9.6 S3 M3LB2	114	C212_ 9.6 P112 BN112M2	115
301	121	1.7	4.6	3180	C352_ 4.6 S3 M3LC4	110	C352_ 4.6 P112 BN112M4	121
309	118	1.5	9.3	2840	C312_ 9.3 S3 M3LB2	117	C312_ 9.3 P112 BN112M2	118
330	110	1.0	8.7	1660	C212_ 8.7 S3 M3LB2	114	C212_ 8.7 P112 BN112M2	115
343	106	1.6	8.4	2780	C312_ 8.4 S3 M3LB2	117	C312_ 8.4 P112 BN112M2	118
372	98	1.5	3.7	2640	C312_ 3.7 S3 M3LC4	117	C312_ 3.7 P112 BN112M4	118
375	97	0.9	3.7	1560	C212_ 3.7 S3 M3LC4	114	C212_ 3.7 P112 BN112M4	115
399	91	2.2	3.5	3010	C352_ 3.5 S3 M3LC4	110	C352_ 3.5 P112 BN112M4	121
401	91	1.8	7.2	2690	C312_ 7.2 S3 M3LB2	117	C312_ 7.2 P112 BN112M2	118
405	90	1.2	7.1	1650	C212_ 7.1 S3 M3LB2	114	C212_ 7.1 P112 BN112M2	115
445	82	1.9	6.5	2620	C312_ 6.5 S3 M3LB2	117	C312_ 6.5 P112 BN112M2	118
450	81	1.2	6.4	1620	C212_ 6.4 S3 M3LB2	114	C212_ 6.4 P112 BN112M2	115
458	79	1.9	6.3	2530	C312_ 6.3 S3 M3LB2	117	C312_ 6.3 P112 BN112M2	118
471	77	1.1	6.1	1540	C212_ 6.1 S3 M3LB2	114	C212_ 6.1 P112 BN112M2	115
483	75	1.7	2.9	2500	C312_ 2.9 S3 M3LC4	117	C312_ 2.9 P112 BN112M4	118
511	71	1.1	2.7	1530	C212_ 2.7 S3 M3LC4	114	C212_ 2.7 P112 BN112M4	115
517	70	2.9	2.7	2840	C352_ 2.7 S3 M3LC4	110	C352_ 2.7 P112 BN112M4	121
580	63	2.2	5.0	2410	C312_ 5.0 S3 M3LB2	117	C312_ 5.0 P112 BN112M2	118
602	60	1.3	4.8	1500	C212_ 4.8 S3 M3LB2	114	C212_ 4.8 P112 BN112M2	115



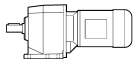

## 4 kW



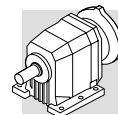

$n_2$ min <sup>-1</sup>	$M_2$ Nm	S	i	$R_{n2}$ N				
621	58	3.4	4.6	2720	C352_ 4.6 S3 M3LB2	110	C352_ 4.6 P112 BN112M2	121
768	47	2.5	3.7	2250	C312_ 3.7 S3 M3LB2	117	C312_ 3.7 P112 BN112M2	120
774	47	1.5	3.7	1450	C212_ 3.7 S3 M3LB2	114	C212_ 3.7 P112 BN112M2	115
997	36	2.9	2.9	2100	C312_ 2.9 S3 M3LB2	117	C312_ 2.9 P112 BN112M2	118
1054	34	1.9	2.7	1370	C212_ 2.7 S3 M3LB2	114	C212_ 2.7 P112 BN112M2	115

## 5.5 kW

3.8	12630	1.0	380.5	85000	C1004_ 380.5 S4 M4SA4	141	C1004_ 380.5 P132 BN132S4	142
4.4	10741	1.1	323.6	85000	C1004_ 323.6 S4 M4SA4	141	C1004_ 323.6 P132 BN132S4	142
4.8	9974	1.2	300.5	85000	C1004_ 300.5 S4 M4SA4	141	C1004_ 300.5 P132 BN132S4	142
5.5	8730	1.4	263.0	85000	C1004_ 263.0 S4 M4SA4	141	C1004_ 263.0 P132 BN132S4	142
5.9	8106	1.5	244.2	85000	C1004_ 244.2 S4 M4SA4	141	C1004_ 244.2 P132 BN132S4	142
6.2	7691	0.9	231.7	60000	C904_ 231.7 S4 M4SA4	138	C904_ 231.7 P132 BN132S4	139
6.8	7050	1.0	212.4	60000	C904_ 212.4 S4 M4SA4	138	C904_ 212.4 P132 BN132S4	139
7.2	6625	1.8	199.6	85000	C1004_ 199.6 S4 M4SA4	141	C1004_ 199.6 P132 BN132S4	142
8.4	5838	1.2	172.1	60000	C903_ 172.1 S4 M4SA4	138	C903_ 172.1 P132 BN132S4	139
9.6	5103	2.4	150.4	85000	C1003_ 150.4 S4 M4SA4	141	C1003_ 150.4 P132 BN132S4	142
9.8	4964	1.5	146.3	60000	C903_ 146.3 S4 M4SA4	138	C903_ 146.3 P132 BN132S4	139
12.1	4052	1.0	119.5	35000	C803_ 119.5 S4 M4SA4	135	C803_ 119.5 P132 BN132S4	136
12.3	3960	1.8	116.7	60000	C903_ 116.7 S4 M4SA4	138	C903_ 116.7 P132 BN132S4	139
14.8	3304	1.2	97.4	35000	C803_ 97.4 S4 M4SA4	135	C803_ 97.4 P132 BN132S4	136
15.0	3265	2.2	96.2	60000	C903_ 96.2 S4 M4SA4	138	C903_ 96.2 P132 BN132S4	139
17.7	2755	2.6	81.2	59100	C903_ 81.2 S4 M4SA4	138	C903_ 81.2 P132 BN132S4	139
18.7	2609	1.5	76.9	35000	C803_ 76.9 S4 M4SA4	135	C803_ 76.9 P132 BN132S4	136
20.2	2420	1.0	71.3	25000	C703_ 71.3 S4 M4SA4	132	C703_ 71.3 P132 BN132S4	133
20.4	2392	1.7	70.5	35000	C803_ 70.5 S4 M4SA4	135	C803_ 70.5 P132 BN132S4	136
21.9	2234	1.0	65.9	25000	C703_ 65.9 S4 M4SA4	132	C703_ 65.9 P132 BN132S4	133
25.1	1944	2.1	57.3	35000	C803_ 57.3 S4 M4SA4	135	C803_ 57.3 P132 BN132S4	136
25.5	1917	1.2	56.5	25000	C703_ 56.5 S4 M4SA4	132	C703_ 56.5 P132 BN132S4	133
27.6	1770	1.3	52.2	24700	C703_ 52.2 S4 M4SA4	132	C703_ 52.2 P132 BN132S4	133
30	1616	1.0	47.6	15300	C613_ 47.6 S4 M4SA4	129	C613_ 47.6 P132 BN132S4	130
30	1609	2.4	47.4	35000	C803_ 47.4 S4 M4SA4	135	C803_ 47.4 P132 BN132S4	136
32	1516	1.5	44.7	24100	C703_ 44.7 S4 M4SA4	132	C703_ 44.7 P132 BN132S4	133
33	1475	2.6	43.5	35000	C803_ 43.5 S4 M4SA4	135	C803_ 43.5 P132 BN132S4	136
33	1474	1.1	43.4	15000	C613_ 43.4 S4 M4SA4	129	C613_ 43.4 P132 BN132S4	130
35	1400	1.6	41.3	23800	C703_ 41.3 S4 M4SA4	132	C703_ 41.3 P132 BN132S4	133
37	1355	2.4	39.1	35000	C802_ 39.1 S4 M4SA4	135	C802_ 39.1 P132 BN132S4	136
38	1317	1.0	38.0	14800	C612_ 38.0 S4 M4SA4	129	C612_ 38.0 P132 BN132S4	130
41	1204	1.7	34.7	22100	C702_ 34.7 S4 M4SA4	132	C702_ 34.7 P132 BN132S4	133
42	1186	1.0	34.2	14500	C612_ 34.2 S4 M4SA4	129	C612_ 34.2 P132 BN132S4	130
46	1086	3.4	31.3	33400	C802_ 31.3 S4 M4SA4	135	C802_ 31.3 P132 BN132S4	136
47	1055	1.3	30.4	14300	C612_ 30.4 S4 M4SA4	129	C612_ 30.4 P132 BN132S4	130
48	1020	1.0	30.1	9610	C513_ 30.1 S4 M4SA4	126	C513_ 30.1 P132 BN132S4	127
52	961	2.2	27.7	21200	C702_ 27.7 S4 M4SA4	132	C702_ 27.7 P132 BN132S4	133
52	931	1.0	27.4	9490	C513_ 27.4 S4 M4SA4	126	C513_ 27.4 P132 BN132S4	127
53	950	1.4	27.4	13900	C612_ 27.4 S4 M4SA4	129	C612_ 27.4 P132 BN132S4	130
58	860	1.6	24.8	13700	C612_ 24.8 S4 M4SA4	129	C612_ 24.8 P132 BN132S4	130
62	809	1.0	23.4	9310	C512_ 23.4 S4 M4SA4	126	C512_ 23.4 P132 BN132S4	127
63	792	2.7	22.9	20400	C702_ 22.9 S4 M4SA4	132	C702_ 22.9 P132 BN132S4	133
64	775	1.7	22.4	13400	C612_ 22.4 S4 M4SA4	129	C612_ 22.4 P132 BN132S4	130
69	726	1.1	21.0	9150	C512_ 21.0 S4 M4SA4	126	C512_ 21.0 P132 BN132S4	127
73	679	2.0	19.6	13100	C612_ 19.6 S4 M4SA4	129	C612_ 19.6 P132 BN132S4	130
75	668	3.1	19.3	19700	C702_ 19.3 S4 M4SA4	132	C702_ 19.3 P132 BN132S4	133
76	655	1.2	18.9	9030	C512_ 18.9 S4 M4SA4	126	C512_ 18.9 P132 BN132S4	127
82	612	2.2	17.7	12700	C612_ 17.7 S4 M4SA4	129	C612_ 17.7 P132 BN132S4	130
87	575	1.4	16.6	8810	C512_ 16.6 S4 M4SA4	126	C512_ 16.6 P132 BN132S4	127
90	552	2.4	15.9	12500	C612_ 15.9 S4 M4SA4	129	C612_ 15.9 P132 BN132S4	130
96	519	1.5	15.0	8660	C512_ 15.0 S4 M4SA4	126	C512_ 15.0 P132 BN132S4	127
100	497	2.7	14.3	12100	C612_ 14.3 S4 M4SA4	129	C612_ 14.3 P132 BN132S4	130
101	494	0.9	14.2	4000	C412_ 14.2 S4 M4SA4	123	C412_ 14.2 P132 BN132S4	124
110	455	1.6	13.1	8420	C512_ 13.1 S4 M4SA4	126	C512_ 13.1 P132 BN132S4	127
116	429	1.0	12.4	4060	C412_ 12.4 S4 M4SA4	123	C412_ 12.4 P132 BN132S4	124

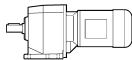

## 5.5 kW



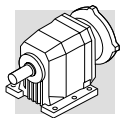

$n_2$ min <sup>-1</sup>	$M_2$ Nm	S	i	$R_{n2}$ N				
119	419	3.2	12.1	11600	C612_ 12.1 S4 M4SA4	131	C612_ 12.1 P132 BN132S4	130
122	410	1.9	11.8	8250	C512_ 11.8 S4 M4SA4	126	C512_ 11.8 P132 BN132S4	127
129	387	1.1	11.2	4030	C412_ 11.2 S4 M4SA4	123	C412_ 11.2 P132 BN132S4	124
148	338	2.0	9.8	7890	C512_ 9.8 S4 M4SA4	126	C512_ 9.8 P132 BN132S4	127
150	333	1.2	9.6	4030	C412_ 9.6 S4 M4SA4	123	C412_ 9.6 P132 BN132S4	124
164	305	2.2	8.8	7700	C512_ 8.8 S4 M4SA4	126	C512_ 8.8 P132 BN132S4	127
167	299	1.3	8.6	3980	C412_ 8.6 S4 M4SA4	123	C412_ 8.6 P132 BN132S4	124
186	269	2.4	7.8	7460	C512_ 7.8 S4 M4SA4	126	C512_ 7.8 P132 BN132S4	127
204	245	1.4	7.1	3920	C412_ 7.1 S4 M4SA4	123	C412_ 7.1 P132 BN132S4	124
206	242	2.6	7.0	7280	C512_ 7.0 S4 M4SA4	126	C512_ 7.0 P132 BN132S4	127
226	221	1.6	6.4	3840	C412_ 6.4 S4 M4SA4	123	C412_ 6.4 P132 BN132S4	124
240	208	3.2	6.0	9480	C612_ 6.0 S4 M4SA4	129	C612_ 6.0 P132 BN132S4	130
242	206	1.3	6.0	3430	C412_ 6.0 S4 M4SA4	123	C412_ 6.0 P132 BN132S4	124
256	195	2.2	5.6	6720	C512_ 5.6 S4 M4SA4	126	C512_ 5.6 P132 BN132S4	127
259	193	1.7	11.2	3770	C412_ 11.2 S4 M4SA2	123	C412_ 11.2 P132 BN132SA2	124
262	191	1.3	3.6	3410	C412_ 3.6 S4 M4LB6	123	C412_ 3.6 P132 BN132MB6	124
286	175	2.4	3.3	6530	C512_ 3.3 S4 M4LB6	126	C512_ 3.3 P132 BN132MB6	127
301	166	1.9	9.6	3680	C412_ 9.6 S4 M4SA2	123	C412_ 9.6 P132 BN132SA2	124
309	162	1.6	4.7	3360	C412_ 4.7 S4 M4SA4	123	C412_ 4.7 P132 BN132S4	124
323	154	2.8	4.5	6330	C512_ 4.5 S4 M4SA4	126	C512_ 4.5 P132 BN132S4	127
334	149	2.0	8.6	3600	C412_ 8.6 S4 M4SA2	123	C412_ 8.6 P132 BN132SA2	124
355	140	1.7	2.7	3300	C412_ 2.7 S4 M4LB6	123	C412_ 2.7 P132 BN132MB6	124
359	139	2.9	2.6	6150	C512_ 2.6 S4 M4LB6	126	C512_ 2.6 P132 BN132MB6	127
399	125	2.0	3.6	3240	C412_ 3.6 S4 M4SA4	123	C412_ 3.6 P132 BN132S4	124
409	122	2.3	7.1	3460	C412_ 7.1 S4 M4SA2	123	C412_ 7.1 P132 BN132SA2	124
454	110	2.5	6.4	3370	C412_ 6.4 S4 M4SA2	123	C412_ 6.4 P132 BN132SA2	124
485	103	2.5	6.0	3140	C412_ 6.0 S4 M4SA2	123	C412_ 6.0 P132 BN132SA2	124
542	92	2.7	2.7	3070	C412_ 2.7 S4 M4SA4	123	C412_ 2.7 P132 BN132S4	124
620	81	3.2	4.7	2990	C412_ 4.7 S4 M4SA2	123	C412_ 4.7 P132 BN132SA2	124

## 7.5 kW

5.5	11904	1.0	263.0	85000	C1004_ 263.0 S4 M4LA4	141	C1004_ 263.0 P132 BN132MA4	142
7.2	9034	1.3	199.6	85000	C1004_ 199.6 S4 M4LA4	141	C1004_ 199.6 P132 BN132MA4	142
8.4	7961	0.9	172.1	60000	C903_ 172.1 S4 M4LA4	138	C903_ 172.1 P132 BN132MA4	139
9.6	6958	1.7	150.4	85000	C1003_ 150.4 S4 M4LA4	141	C1003_ 150.4 P132 BN132MA4	142
9.8	6769	1.1	146.3	59600	C903_ 146.3 S4 M4LA4	138	C903_ 146.3 P132 BN132MA4	139
12.3	5400	1.3	116.7	58600	C903_ 116.7 S4 M4LA4	138	C903_ 116.7 P132 BN132MA4	139
12.9	5176	2.3	111.9	85000	C1003_ 111.9 S4 M4LA4	141	C1003_ 111.9 P132 BN132MA4	142
16.1	4129	1.0	89.3	35000	C803_ 89.3 S4 M4LA4	135	C803_ 89.3 P132 BN132MA4	136
16.3	4081	1.7	88.2	56600	C903_ 88.2 S4 M4LA4	138	C903_ 88.2 P132 BN132MA4	139
16.8	3958	3.0	85.6	85000	C1003_ 85.6 S4 M4LA4	141	C1003_ 85.6 P132 BN132MA4	142
19.3	3444	2.1	74.4	55200	C903_ 74.4 S4 M4LA4	138	C903_ 74.4 P132 BN132MA4	139
20.4	3261	1.2	70.5	35000	C803_ 70.5 S4 M4LA4	135	C803_ 70.5 P132 BN132MA4	136
23.0	2891	1.4	62.5	35000	C803_ 62.5 S4 M4LA4	135	C803_ 62.5 P132 BN132MA4	136
24.3	2738	2.6	59.2	53000	C903_ 59.2 S4 M4LA4	138	C903_ 59.2 P132 BN132MA4	139
27.6	2413	1.0	52.2	22900	C703_ 52.2 S4 M4LA4	132	C703_ 52.2 P132 BN132MA4	133
30	2195	1.7	47.4	35000	C803_ 47.4 S4 M4LA4	135	C803_ 47.4 P132 BN132MA4	136
32	2068	1.1	44.7	22500	C703_ 44.7 S4 M4LA4	132	C703_ 44.7 P132 BN132MA4	133
35	1909	1.2	41.3	22300	C703_ 41.3 S4 M4LA4	132	C703_ 41.3 P132 BN132MA4	133
37	1848	1.7	39.1	33600	C802_ 39.1 S4 M4LA4	135	C802_ 39.1 P132 BN132MA4	136
40	1672	0.9	36.1	13300	C613_ 36.1 S4 M4LA4	129	C613_ 36.1 P132 BN132MA4	130
41	1642	1.3	34.7	20500	C702_ 34.7 S4 M4LA4	132	C702_ 34.7 P132 BN132MA4	133
44	1525	1.0	33.0	13100	C613_ 33.0 S4 M4LA4	129	C613_ 33.0 P132 BN132MA4	130
46	1481	2.5	31.3	32200	C802_ 31.3 S4 M4LA4	135	C802_ 31.3 P132 BN132MA4	136
47	1439	0.9	30.4	13000	C612_ 30.4 S4 M4LA4	129	C612_ 30.4 P132 BN132MA4	130
49	1358	1.1	29.4	13100	C613_ 29.4 S4 M4LA4	129	C613_ 29.4 P132 BN132MA4	130
52	1310	1.6	27.7	20000	C702_ 27.7 S4 M4LA4	132	C702_ 27.7 P132 BN132MA4	133
53	1296	1.0	27.4	12800	C612_ 27.4 S4 M4LA4	129	C612_ 27.4 P132 BN132MA4	130
55	1226	3.0	25.9	31000	C802_ 25.9 S4 M4LA4	135	C802_ 25.9 P132 BN132MA4	136
58	1173	1.2	24.8	12700	C612_ 24.8 S4 M4LA4	129	C612_ 24.8 P132 BN132MA4	130
60	1132	3.1	24.0	30500	C802_ 24.0 S4 M4LA4	135	C802_ 24.0 P132 BN132MA4	136
63	1080	1.9	22.9	19400	C702_ 22.9 S4 M4LA4	132	C702_ 22.9 P132 BN132MA4	133

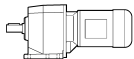

## 7.5 kW



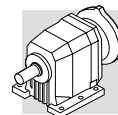

$n_2$ min <sup>-1</sup>	$M_2$ Nm	S	i	$R_{n2}$ N				
64	1056	1.3	22.4	12500	C612_ 22.4 S4 M4LA4	129	C612_ 22.4 P132 BN132MA4	130
65	1051	3.5	22.2	30000	C802_ 22.2 S4 M4LA4	135	C802_ 22.2 P132 BN132MA4	136
73	926	1.5	19.6	12300	C612_ 19.6 S4 M4LA4	129	C612_ 19.6 P132 BN132MA4	130
75	911	2.3	19.3	18900	C702_ 19.3 S4 M4LA4	132	C702_ 19.3 P132 BN132MA4	133
82	834	1.6	17.7	12000	C612_ 17.7 S4 M4LA4	129	C612_ 17.7 P132 BN132MA4	130
86	789	2.6	16.7	18200	C702_ 16.7 S4 M4LA4	132	C702_ 16.7 P132 BN132MA4	133
87	784	1.0	16.6	8070	C512_ 16.6 S4 M4LA4	126	C512_ 16.6 P132 BN132MA4	127
90	753	1.8	15.9	11800	C612_ 15.9 S4 M4LA4	129	C612_ 15.9 P132 BN132MA4	130
96	707	1.1	15.0	8000	C512_ 15.0 S4 M4LA4	126	C512_ 15.0 P132 BN132MA4	127
100	678	2.0	14.3	11500	C612_ 14.3 S4 M4LA4	129	C612_ 14.3 P132 BN132MA4	130
110	620	1.2	13.1	7840	C512_ 13.1 S4 M4LA4	126	C512_ 13.1 P132 BN132MA4	127
111	616	3.4	13.0	17500	C702_ 13.0 S4 M4LA4	132	C702_ 13.0 P132 BN132MA4	133
119	571	2.4	12.1	11100	C612_ 12.1 S4 M4LA4	129	C612_ 12.1 P132 BN132MA4	130
122	559	1.4	11.8	7730	C512_ 11.8 S4 M4LA4	126	C512_ 11.8 P132 BN132MA4	127
132	515	2.6	10.9	10900	C612_ 10.9 S4 M4LA4	129	C612_ 10.9 P132 BN132MA4	130
147	464	2.9	9.8	10600	C612_ 9.8 S4 M4LA4	129	C612_ 9.8 P132 BN132MA4	130
148	461	1.5	9.8	7450	C512_ 9.8 S4 M4LA4	126	C512_ 9.8 P132 BN132MA4	127
163	418	3.2	8.8	10300	C612_ 8.8 S4 M4LA4	129	C612_ 8.8 P132 BN132MA4	130
164	415	1.6	8.8	7320	C512_ 8.8 S4 M4LA4	126	C512_ 8.8 P132 BN132MA4	127
167	408	0.9	8.6	3430	C412_ 8.6 S4 M4LA4	123	C412_ 8.6 P132 BN132MA4	124
186	366	1.7	7.8	7120	C512_ 7.8 S4 M4LA4	126	C512_ 7.8 P132 BN132MA4	127
204	334	1.1	7.1	3470	C412_ 7.1 S4 M4LA4	123	C412_ 7.1 P132 BN132MA4	124
206	330	1.9	7.0	6970	C512_ 7.0 S4 M4LA4	126	C512_ 7.0 P132 BN132MA4	127
226	301	1.1	6.4	3440	C412_ 6.4 S4 M4LA4	123	C412_ 6.4 P132 BN132MA4	124
240	284	2.3	6.0	9180	C612_ 6.0 S4 M4LA4	129	C612_ 6.0 P132 BN132MA4	130
242	281	0.9	6.0	2920	C412_ 6.0 S4 M4LA4	123	C412_ 6.0 P132 BN132MA4	124
256	266	1.6	5.6	6410	C512_ 5.6 S4 M4LA4	126	C512_ 5.6 P132 BN132MA4	127
309	220	1.2	4.7	2960	C412_ 4.7 S4 M4LA4	123	C412_ 4.7 P132 BN132MA4	124
316	215	3.1	4.6	8550	C612_ 4.6 S4 M4LA4	129	C612_ 4.6 P132 BN132MA4	130
323	210	2.1	4.5	6090	C512_ 4.5 S4 M4LA4	126	C512_ 4.5 P132 BN132MA4	127
339	201	3.3	2.8	8390	C612_ 2.8 S5 M5SA6	129	C612_ 2.8 P160 BN160M6	130
363	187	2.1	2.6	5920	C512_ 2.6 S5 M5SA6	126	C512_ 2.6 P160 BN160M6	127
399	171	1.5	3.6	2930	C412_ 3.6 S4 M4LA4	123	C412_ 3.6 P132 BN132MA4	124
410	166	1.7	7.1	3240	C412_ 7.1 S4 M4SB2	123	C412_ 7.1 P132 BN132SB2	124
435	156	2.7	3.3	5660	C512_ 3.3 S4 M4LA4	126	C512_ 3.3 P132 BN132MA4	127
456	149	1.8	6.4	3170	C412_ 6.4 S4 M4SB2	123	C412_ 6.4 P132 BN132SB2	124
487	140	1.9	6.0	2880	C412_ 6.0 S4 M4SB2	123	C412_ 6.0 P132 BN132SB2	124
515	132	3.1	5.6	5420	C512_ 5.6 S4 M4SB2	126	C512_ 5.6 P132 BN132SB2	127
542	126	1.9	2.7	2840	C412_ 2.7 S4 M4LA4	123	C412_ 2.7 P132 BN132MA4	124
548	124	3.2	2.6	5330	C512_ 2.6 S4 M4LA4	126	C512_ 2.6 P132 BN132MA4	127
622	109	2.4	4.7	2790	C412_ 4.7 S4 M4SB2	123	C412_ 4.7 P132 BN132SB2	124
803	85	3.0	3.6	2670	C412_ 3.6 S4 M4SB2	123	C412_ 3.6 P132 BN132SB2	124

## 9.2 kW

7.2	11082	1.1	199.6	85000	C1004_ 199.6 S4 M4LB4	141	C1004_ 199.6 P132 BN132MB4	142
7.8	10294	1.2	185.4	85000	C1004_ 185.4 S4 M4LB4	141	C1004_ 185.4 P132 BN132MB4	142
9.6	8536	1.4	150.4	85000	C1003_ 150.4 S4 M4LB4	141	C1003_ 150.4 P132 BN132MB4	142
10.7	7611	0.9	134.1	54900	C903_ 134.1 S4 M4LB4	138	C903_ 134.1 P132 BN132MB4	139
13.5	6072	1.2	107.0	54600	C903_ 107.0 S4 M4LB4	138	C903_ 107.0 P132 BN132MB4	139
15.0	5461	1.3	96.2	54200	C903_ 96.2 S4 M4LB4	138	C903_ 96.2 P132 BN132MB4	139
15.5	5259	2.3	92.7	85000	C1003_ 92.7 S4 M4LB4	141	C1003_ 92.7 P132 BN132MB4	142
17.7	4608	1.6	81.2	53300	C903_ 81.2 S4 M4LB4	138	C903_ 81.2 P132 BN132MB4	139
19.3	4224	1.7	74.4	52700	C903_ 74.4 S4 M4LB4	138	C903_ 74.4 P132 BN132MB4	139
20.4	4001	1.0	70.5	35000	C803_ 70.5 S4 M4LB4	135	C803_ 70.5 P132 BN132MB4	136
24.3	3359	2.1	59.2	51100	C903_ 59.2 S4 M4LB4	138	C903_ 59.2 P132 BN132MB4	139
25.1	3251	1.2	57.3	35000	C803_ 57.3 S4 M4LB4	135	C803_ 57.3 P132 BN132MB4	136
28.6	2854	2.5	50.3	49700	C903_ 50.3 S4 M4LB4	138	C903_ 50.3 P132 BN132MB4	139
30	2692	1.4	47.4	34900	C803_ 47.4 S4 M4LB4	135	C803_ 47.4 P132 BN132MB4	136
32	2536	0.9	44.7	21100	C703_ 44.7 S4 M4LB4	132	C703_ 44.7 P132 BN132MB4	133
33	2468	1.5	43.5	34400	C803_ 43.5 S4 M4LB4	135	C803_ 43.5 P132 BN132MB4	136
35	2341	1.0	41.3	21000	C703_ 41.3 S4 M4LB4	132	C703_ 41.3 P132 BN132MB4	133
37	2267	1.4	39.1	32300	C802_ 39.1 S4 M4LB4	135	C802_ 39.1 P132 BN132MB4	136

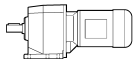



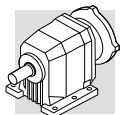

## 9.2 kW

$n_2$ min <sup>-1</sup>	$M_2$ Nm	S	i	$R_{n2}$ N				
41	2034	2.7	35.1	46200	C902_ 35.1 S4 M4LB4	138	C902_ 35.1 P132 BN132MB4	139
41	2014	1.0	34.7	19200	C702_ 34.7 S4 M4LB4	132	C702_ 34.7 P132 BN132MB4	133
46	1816	2.0	31.3	31100	C802_ 31.3 S4 M4LB4	135	C802_ 31.3 P132 BN132MB4	136
49	1706	3.5	29.4	44600	C902_ 29.4 S4 M4LB4	138	C902_ 29.4 P132 BN132MB4	139
52	1607	1.3	27.7	18900	C702_ 27.7 S4 M4LB4	132	C702_ 27.7 P132 BN132MB4	133
58	1439	0.9	24.8	11800	C612_ 24.8 S4 M4LB4	129	C612_ 24.8 P132 BN132MB4	130
63	1325	1.6	22.9	18500	C702_ 22.9 S4 M4LB4	132	C702_ 22.9 P132 BN132MB4	133
64	1296	1.0	22.4	11700	C612_ 22.4 S4 M4LB4	129	C612_ 22.4 P132 BN132MB4	130
65	1289	2.9	22.2	29200	C802_ 22.2 S4 M4LB4	135	C802_ 22.2 P132 BN132MB4	136
73	1136	1.2	19.6	11600	C612_ 19.6 S4 M4LB4	129	C612_ 19.6 P132 BN132MB4	130
75	1118	1.9	19.3	18100	C702_ 19.3 S4 M4LB4	132	C702_ 19.3 P132 BN132MB4	133
82	1023	1.3	17.7	11400	C612_ 17.7 S4 M4LB4	129	C612_ 17.7 P132 BN132MB4	130
86	968	2.1	16.7	17500	C702_ 16.7 S4 M4LB4	132	C702_ 16.7 P132 BN132MB4	133
90	923	1.5	15.9	11200	C612_ 15.9 S4 M4LB4	129	C612_ 15.9 P132 BN132MB4	130
94	889	2.4	15.3	17500	C702_ 15.3 S4 M4LB4	132	C702_ 15.3 P132 BN132MB4	133
96	867	0.9	15.0	7430	C512_ 15.0 S4 M4LB4	126	C512_ 15.0 P132 BN132MB4	127
100	832	1.6	14.3	11000	C612_ 14.3 S4 M4LB4	129	C612_ 14.3 P132 BN132MB4	130
102	817	2.6	14.1	17000	C702_ 14.1 S4 M4LB4	132	C702_ 14.1 P132 BN132MB4	133
110	761	1.0	13.1	7340	C512_ 13.1 S4 M4LB4	126	C512_ 13.1 P132 BN132MB4	127
111	755	2.8	13.0	17000	C702_ 13.0 S4 M4LB4	132	C702_ 13.0 P132 BN132MB4	133
119	701	1.9	12.1	10700	C612_ 12.1 S4 M4LB4	129	C612_ 12.1 P132 BN132MB4	130
122	686	1.1	11.8	7280	C512_ 11.8 S4 M4LB4	126	C512_ 11.8 P132 BN132MB4	127
127	658	3.2	22.9	16500	C702_ 22.9 S4 M4LA2	132	C702_ 22.9 P132 BN132M2	133
132	631	2.1	10.9	10500	C612_ 10.9 S4 M4LB4	129	C612_ 10.9 P132 BN132MB4	130
147	569	2.4	9.8	10300	C612_ 9.8 S4 M4LB4	129	C612_ 9.8 P132 BN132MB4	130
148	565	1.2	9.8	7080	C512_ 9.8 S4 M4LB4	126	C512_ 9.8 P132 BN132MB4	127
163	513	2.6	8.8	10000	C612_ 8.8 S4 M4LB4	129	C612_ 8.8 P132 BN132MB4	130
164	510	1.3	8.8	6990	C512_ 8.8 S4 M4LB4	126	C512_ 8.8 P132 BN132MB4	127
186	449	1.4	7.8	6820	C512_ 7.8 S4 M4LB4	126	C512_ 7.8 P132 BN132MB4	127
192	434	3.1	7.5	9670	C612_ 7.5 S4 M4LB4	129	C612_ 7.5 P132 BN132MB4	130
206	405	1.6	7.0	6710	C512_ 7.0 S4 M4LB4	126	C512_ 7.0 P132 BN132MB4	127
214	391	3.5	6.7	9410	C612_ 6.7 S4 M4LB4	129	C612_ 6.7 P132 BN132MB4	130
226	369	0.9	6.4	3100	C412_ 6.4 S4 M4LB4	123	C412_ 6.4 P132 BN132MB4	124
240	348	1.9	6.0	8930	C612_ 6.0 S4 M4LB4	129	C612_ 6.0 P132 BN132MB4	130
256	326	1.3	5.6	6150	C512_ 5.6 S4 M4LB4	126	C512_ 5.6 P132 BN132MB4	127
260	321	1.0	11.2	3110	C412_ 11.2 S4 M4LA2	123	C412_ 11.2 P132 BN132M2	124
309	270	1.0	4.7	2620	C412_ 4.7 S4 M4LB4	123	C412_ 4.7 P132 BN132MB4	124
316	264	2.5	4.6	8360	C612_ 4.6 S4 M4LB4	129	C612_ 4.6 P132 BN132MB4	130
323	258	1.7	4.5	5880	C512_ 4.5 S4 M4LB4	126	C512_ 4.5 P132 BN132MB4	127
336	249	1.2	8.6	3090	C412_ 8.6 S4 M4LA2	123	C412_ 8.6 P132 BN132M2	124
374	223	2.3	7.8	5870	C512_ 7.8 S4 M4LA2	126	C512_ 7.8 P132 BN132M2	127
399	209	1.2	3.6	2670	C412_ 3.6 S4 M4LB4	123	C412_ 3.6 P132 BN132MB4	124
410	203	1.4	7.1	3050	C412_ 7.1 S4 M4LA2	123	C412_ 7.1 P132 BN132M2	124
415	201	2.5	7.0	5730	C512_ 7.0 S4 M4LA2	126	C512_ 7.0 P132 BN132M2	127
435	192	2.2	3.3	5510	C512_ 3.3 S4 M4LB4	126	C512_ 3.3 P132 BN132MB4	127
456	183	1.5	6.4	3000	C412_ 6.4 S4 M4LA2	123	C412_ 6.4 P132 BN132M2	124
487	171	1.5	6.0	2660	C412_ 6.0 S4 M4LA2	123	C412_ 6.0 P132 BN132M2	124
515	162	2.6	5.6	5290	C512_ 5.6 S4 M4LA2	126	C512_ 5.6 P132 BN132M2	127
542	154	1.6	2.7	2650	C412_ 2.7 S4 M4LB4	123	C412_ 2.7 P132 BN132MB4	124
548	152	2.6	2.6	5210	C512_ 2.6 S4 M4LB4	126	C512_ 2.6 P132 BN132MB4	127
622	134	1.9	4.7	2620	C412_ 4.7 S4 M4LA2	123	C412_ 4.7 P132 BN132M2	124
651	128	3.4	4.5	4980	C512_ 4.5 S4 M4LA2	126	C512_ 4.5 P132 BN132M2	127
803	104	2.5	3.6	2540	C412_ 3.6 S4 M4LA2	123	C412_ 3.6 P132 BN132M2	124
1091	77	3.2	2.7	2410	C412_ 2.7 S4 M4LA2	123	C412_ 2.7 P132 BN132M2	124

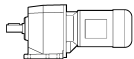



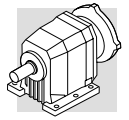

# 11 kW

$n_2$ min <sup>-1</sup>	$M_2$ Nm	S	i	$R_{n2}$ N				
7.2	13251	0.9	199.6	85000	C1004_199.6 S4 M4LC4	141	C1004_199.6 P160 BN160M4	142
9.6	10206	1.2	150.4	85000	C1003_150.4 S4 M4LC4	141	C1003_150.4 P160 BN160M4	142
12.3	7920	0.9	116.7	50800	C903_116.7 S4 M4LC4	138	C903_116.7 P160 BN160M4	139
12.9	7592	1.6	111.9	85000	C1003_111.9 S4 M4LC4	141	C1003_111.9 P160 BN160M4	142
15.5	6287	1.9	92.7	85000	C1003_92.7 S4 M4LC4	141	C1003_92.7 P160 BN160M4	142
16.3	5985	1.2	88.2	50700	C903_88.2 S4 M4LC4	138	C903_88.2 P160 BN160M4	139
19.3	5051	1.4	74.4	50200	C903_74.4 S4 M4LC4	138	C903_74.4 P160 BN160M4	139
20.7	4710	2.5	69.4	84800	C1003_69.4 S4 M4LC4	141	C1003_69.4 P160 BN160M4	142
24.3	4016	1.8	59.2	49000	C903_59.2 S4 M4LC4	138	C903_59.2 P160 BN160M4	139
25.1	3887	1.0	57.3	34200	C803_57.3 S4 M4LC4	135	C803_57.3 P160 BN160M4	136
28.6	3413	2.1	50.3	48000	C903_50.3 S4 M4LC4	138	C903_50.3 P160 BN160M4	139
30	3219	1.2	47.4	33500	C803_47.4 S4 M4LC4	135	C803_47.4 P160 BN160M4	136
33	2951	1.3	43.5	33100	C803_43.5 S4 M4LC4	135	C803_43.5 P160 BN160M4	136
37	2673	2.7	39.4	46100	C903_39.4 S4 M4LC4	138	C903_39.4 P160 BN160M4	139
37	2711	1.2	39.1	30900	C802_39.1 S4 M4LC4	135	C802_39.1 P160 BN160M4	136
41	2432	2.2	35.1	45000	C902_35.1 S4 M4LC4	138	C902_35.1 P160 BN160M4	139
46	2172	1.7	31.3	30000	C802_31.3 S4 M4LC4	135	C802_31.3 P160 BN160M4	136
52	1921	1.1	27.7	17800	C702_27.7 S4 M4LC4	132	C702_27.7 P160 BN160M4	133
55	1798	2.1	25.9	29200	C802_25.9 S4 M4LC4	135	C802_25.9 P160 BN160M4	136
63	1584	1.3	22.9	17600	C702_22.9 S4 M4LC4	132	C702_22.9 P160 BN160M4	133
65	1542	2.4	22.2	28400	C802_22.2 S4 M4LC4	135	C802_22.2 P160 BN160M4	136
70	1423	2.5	20.5	28000	C802_20.5 S4 M4LC4	135	C802_20.5 P160 BN160M4	136
73	1358	1.0	19.6	10800	C612_19.6 S4 M4LC4	129	C612_19.6 P160 BN160M4	130
75	1337	1.6	19.3	17300	C702_19.3 S4 M4LC4	132	C702_19.3 P160 BN160M4	133
80	1251	3.0	18.1	27300	C802_18.1 S4 M4LC4	135	C802_18.1 P160 BN160M4	136
82	1223	1.1	17.7	10700	C612_17.7 S4 M4LC4	129	C612_17.7 P160 BN160M4	130
86	1158	1.8	16.7	16800	C702_16.7 S4 M4LC4	132	C702_16.7 P160 BN160M4	133
86	1155	3.0	16.7	26900	C802_16.7 S4 M4LC4	135	C802_16.7 P160 BN160M4	136
90	1104	1.2	15.9	10700	C612_15.9 S4 M4LC4	129	C612_15.9 P160 BN160M4	130
94	1063	2.0	15.3	16800	C702_15.3 S4 M4LC4	132	C702_15.3 P160 BN160M4	133
100	994	1.4	14.3	10500	C612_14.3 S4 M4LC4	129	C612_14.3 P160 BN160M4	130
102	977	2.2	14.1	16400	C702_14.1 S4 M4LC4	132	C702_14.1 P160 BN160M4	133
111	903	2.3	13.0	16400	C702_13.0 S4 M4LC4	132	C702_13.0 P160 BN160M4	133
119	838	1.6	12.1	10300	C612_12.1 S4 M4LC4	129	C612_12.1 P160 BN160M4	130
122	820	0.9	11.8	6810	C512_11.8 S4 M4LC4	126	C512_11.8 P160 BN160M4	127
128	777	2.8	11.2	15800	C702_11.2 S4 M4LC4	132	C702_11.2 P160 BN160M4	133
132	755	1.8	10.9	10100	C612_10.9 S4 M4LC4	129	C612_10.9 P160 BN160M4	130
141	707	3.0	10.2	15700	C702_10.2 S4 M4LC4	132	C702_10.2 P160 BN160M4	133
147	680	2.0	9.8	9910	C612_9.8 S4 M4LC4	129	C612_9.8 P160 BN160M4	130
148	676	1.0	9.8	6690	C512_9.8 S4 M4LC4	126	C512_9.8 P160 BN160M4	127
151	660	3.3	9.5	15400	C702_9.5 S4 M4LC4	132	C702_9.5 P160 BN160M4	133
163	613	2.2	8.8	9690	C612_8.8 S4 M4LC4	129	C612_8.8 P160 BN160M4	130
164	609	1.1	8.8	6640	C512_8.8 S4 M4LC4	126	C512_8.8 P160 BN160M4	127
186	537	1.2	7.8	6510	C512_7.8 S4 M4LC4	126	C512_7.8 P160 BN160M4	127
192	519	2.6	7.5	9390	C612_7.5 S4 M4LC4	129	C612_7.5 P160 BN160M4	130
206	484	1.3	7.0	6430	C512_7.0 S4 M4LC4	126	C512_7.0 P160 BN160M4	127
214	467	2.9	6.7	9150	C612_6.7 S4 M4LC4	129	C612_6.7 P160 BN160M4	130
240	416	1.6	6.0	8670	C612_6.0 S4 M4LC4	129	C612_6.0 P160 BN160M4	130
256	390	1.1	5.6	5880	C512_5.6 S4 M4LC4	126	C512_5.6 P160 BN160M4	127
290	344	1.2	3.3	5770	C512_3.3 S5 M5SB6	126	C512_3.3 P160 BN160L6	127
316	316	2.1	4.6	8160	C612_4.6 S4 M4LC4	129	C612_4.6 P160 BN160M4	130
323	309	1.4	4.5	5660	C512_4.5 S4 M4LC4	126	C512_4.5 P160 BN160M4	127
338	295	1.0	8.6	2850	C412_8.6 S4 M4LC2	123		
365	273	1.5	2.6	5540	C512_2.6 S5 M5SB6	126	C512_2.6 P160 BN160L6	127
389	256	2.6	3.7	7760	C612_3.7 S4 M4LC4	129	C612_3.7 P160 BN160M4	130
399	250	1.0	3.6	2390	C412_3.6 S4 M4LC4	123		
413	242	1.2	7.1	2860	C412_7.1 S4 M4LC2	123		
435	229	1.8	3.3	5340	C512_3.3 S4 M4LC4	126	C512_3.3 P160 BN160M4	127
459	217	1.3	6.4	2820	C412_6.4 S4 M4LC2	123		
491	203	1.3	6.0	2440	C412_6.0 S4 M4LC2	123		
511	195	3.4	2.8	7240	C612_2.8 S4 M4LC4	129	C612_2.8 P160 BN160M4	130
519	192	2.2	5.6	5140	C512_5.6 S4 M4LC2	126	C512_5.6 P160 BN160MA2	127
542	184	1.3	2.7	2440	C412_2.7 S4 M4LC4	123		
548	182	2.2	2.6	5080	C512_2.6 S4 M4LC4	126	C512_2.6 P160 BN160M4	127
626	159	1.6	4.7	2440	C412_4.7 S4 M4LC2	123		
656	152	2.9	4.5	4870	C512_4.5 S4 M4LC2	126	C512_4.5 P160 BN160MA2	127
809	123	2.1	3.6	2400	C412_3.6 S4 M4LC2	123		
1098	91	2.7	2.7	2300	C412_2.7 S4 M4LC2	123		

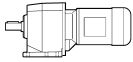



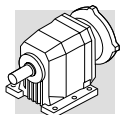

# 15 kW

$n_2$ min <sup>-1</sup>	$M_2$ Nm	S	i	$R_{n2}$ N							
10.5	12728	0.9	92.7	83900			C1003_ 92.7	P180 BN180L6	142		
12.1	10997	1.1	120.5	83800	C1003_ 120.5	S5	M5SB4	141	C1003_ 120.5	P160 BN160L4	142
15.2	8782	0.8	96.2	43600	C903_ 96.2	S5	M5SB4	138	C903_ 96.2	P160 BN160L4	139
15.8	8456	1.4	92.7	82400	C1003_ 92.7	S5	M5SB4	141	C1003_ 92.7	P160 BN160L4	142
18.0	7411	1.0	81.2	44300	C903_ 81.2	S5	M5SB4	138	C903_ 81.2	P160 BN160L4	139
18.4	7249	1.7	79.4	81000	C1003_ 79.4	S5	M5SB4	141	C1003_ 79.4	P160 BN160L4	142
24.7	5402	1.3	59.2	44400	C903_ 59.2	S5	M5SB4	138	C903_ 59.2	P160 BN160L4	139
25.5	5233	2.3	57.4	77400	C1003_ 57.4	S5	M5SB4	141	C1003_ 57.4	P160 BN160L4	142
29.0	4590	1.5	50.3	44100	C903_ 50.3	S5	M5SB4	138	C903_ 50.3	P160 BN160L4	139
32	4218	2.8	46.2	74500	C1003_ 46.2	S5	M5SB4	141	C1003_ 46.2	P160 BN160L4	142
34	3968	1.0	43.5	30300	C803_ 43.5	S5	M5SB4	135	C803_ 43.5	P160 BN160L4	136
37	3595	2.0	39.4	43000	C903_ 39.4	S5	M5SB4	138	C903_ 39.4	P160 BN160L4	139
42	3272	1.7	35.1	42200	C902_ 35.1	S5	M5SB4	138	C902_ 35.1	P160 BN160L4	139
47	2921	1.3	31.3	27500	C802_ 31.3	S5	M5SB4	135	C802_ 31.3	P160 BN160L4	136
54	2533	2.2	27.2	40700	C902_ 27.2	S5	M5SB4	138	C902_ 27.2	P160 BN160L4	139
56	2419	1.5	25.9	27100	C802_ 25.9	S5	M5SB4	135	C802_ 25.9	P160 BN160L4	136
64	2136	2.9	22.9	39500	C902_ 22.9	S5	M5SB4	138	C902_ 22.9	P160 BN160L4	139
66	2073	1.8	22.2	26600	C802_ 22.2	S5	M5SB4	135	C802_ 22.2	P160 BN160L4	136
76	1798	1.2	19.3	15600	C702_ 19.3	S5	M5SB4	132	C702_ 19.3	P160 BN160L4	133
81	1683	2.2	18.1	25800	C802_ 18.1	S5	M5SB4	135	C802_ 18.1	P160 BN160L4	136
92	1485	0.9	15.9	9350	C612_ 15.9	S5	M5SB4	129	C612_ 15.9	P160 BN160L4	130
95	1429	1.5	15.3	15400	C702_ 15.3	S5	M5SB4	132	C702_ 15.3	P160 BN160L4	133
98	1390	2.7	14.9	25000	C802_ 14.9	S5	M5SB4	135	C802_ 14.9	P160 BN160L4	136
102	1337	1.0	14.3	9280	C612_ 14.3	S5	M5SB4	129	C612_ 14.3	P160 BN160L4	130
112	1215	1.7	13.0	15200	C702_ 13.0	S5	M5SB4	132	C702_ 13.0	P160 BN160L4	133
121	1127	1.2	12.1	9270	C612_ 12.1	S5	M5SB4	129	C612_ 12.1	P160 BN160L4	130
121	1120	3.3	12.0	24000	C802_ 12.0	S5	M5SB4	135	C802_ 12.0	P160 BN160L4	136
130	1045	2.1	11.2	14700	C702_ 11.2	S5	M5SB4	132	C702_ 11.2	P160 BN160L4	133
134	1015	1.3	10.9	9140	C612_ 10.9	S5	M5SB4	129	C612_ 10.9	P160 BN160L4	130
149	915	1.5	9.8	9090	C612_ 9.8	S5	M5SB4	129	C612_ 9.8	P160 BN160L4	130
153	888	2.4	9.5	14400	C702_ 9.5	S5	M5SB4	132	C702_ 9.5	P160 BN160L4	133
165	824	1.6	8.8	8930	C612_ 8.8	S5	M5SB4	129	C612_ 8.8	P160 BN160L4	130
182	746	2.8	8.0	14200	C702_ 8.0	S5	M5SB4	132	C702_ 8.0	P160 BN160L4	133
195	698	1.9	7.5	8760	C612_ 7.5	S5	M5SB4	129	C612_ 7.5	P160 BN160L4	130
209	651	1.0	7.0	5810					C512_ 7.0	P160 BN160L4	127
217	628	2.1	6.7	8570	C612_ 6.7	S5	M5SB4	129	C612_ 6.7	P160 BN160L4	130
223	610	1.0	13.1	5760					C512_ 13.1	P160 BN160MB2	127
242	562	2.4	12.1	8430	C612_ 12.1	S5	M5SB2	129	C612_ 12.1	P160 BN160MB2	130
248	550	1.1	11.8	5720					C512_ 11.8	P160 BN160MB2	127
269	506	2.7	10.9	8230	C612_ 10.9	S5	M5SB2	129	C612_ 10.9	P160 BN160MB2	130
298	456	2.9	9.8	8090	C612_ 9.8	S5	M5SB2	129	C612_ 9.8	P160 BN160MB2	130
300	453	1.2	9.8	5570					C512_ 9.8	P160 BN160MB2	127
320	425	1.6	4.6	7690	C612_ 4.6	S5	M5SB4	129	C612_ 4.6	P160 BN160L4	130
328	415	1.0	4.5	5170					C512_ 4.5	P160 BN160L4	127
331	411	3.2	8.8	7880	C612_ 8.8	S5	M5SB2	129	C612_ 8.8	P160 BN160MB2	130
333	408	1.3	8.8	5490					C512_ 8.8	P160 BN160MB2	127
378	360	1.4	7.8	5370					C512_ 7.8	P160 BN160MB2	127
395	345	1.9	3.7	7370	C612_ 3.7	S5	M5SB4	129	C612_ 3.7	P160 BN160L4	130
419	325	1.5	7.0	5280					C512_ 7.0	P160 BN160MB2	127
441	308	1.4	3.3	4970					C512_ 3.3	P160 BN160L4	127
488	279	2.4	6.0	7030	C612_ 6.0	S5	M5SB2	129	C612_ 6.0	P160 BN160MB2	130
518	263	2.5	2.8	6940	C612_ 2.8	S5	M5SB4	129	C612_ 2.8	P160 BN160L4	130
520	262	1.6	5.6	4840					C512_ 5.6	P160 BN160MB2	127
555	245	1.6	2.6	4780					C512_ 2.6	P160 BN160L4	127
643	212	3.1	4.6	6580	C612_ 4.6	S5	M5SB2	129	C612_ 4.6	P160 BN160MB2	130
658	207	2.1	4.5	4630					C512_ 4.5	P160 BN160MB2	127
886	154	2.7	3.3	4330					C512_ 3.3	P160 BN160MB2	127
1115	122	3.3	2.6	4100					C512_ 2.6	P160 BN160MB2	127

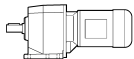

## 18.5 kW



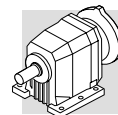

$n_2$ min <sup>-1</sup>	$M_2$ Nm	S	i	$R_{n2}$ N				
13.0	12594	1.0	111.9	76600	C1003_111.9 S5 M5LA4	141	C1003_111.9 P180 BN180M4	142
15.8	10429	1.2	92.7	76700	C1003_92.7 S5 M5LA4	141	C1003_92.7 P180 BN180M4	142
21.0	7813	1.5	69.4	75400	C1003_69.4 S5 M5LA4	141	C1003_69.4 P180 BN180M4	142
22.6	7268	1.0	64.6	40300	C903_64.6 S5 M5LA4	138	C903_64.6 P180 BN180M4	139
26.6	6175	1.2	54.9	40700	C903_54.9 S5 M5LA4	138	C903_54.9 P180 BN180M4	139
27.4	5993	2.0	53.3	73100	C1003_53.3 S5 M5LA4	141	C1003_53.3 P180 BN180M4	142
34	4837	1.5	43.0	40600	C903_43.0 S5 M5LA4	138	C903_43.0 P180 BN180M4	139
34	4831	2.5	42.9	70800	C1003_42.9 S5 M5LA4	141	C1003_42.9 P180 BN180M4	142
42	4035	1.3	35.1	39800	C902_35.1 S5 M5LA4	138	C902_35.1 P180 BN180M4	139
43	3860	3.0	34.3	68100	C1003_34.3 S5 M5LA4	141	C1003_34.3 P180 BN180M4	142
50	3384	1.7	29.4	39100	C902_29.4 S5 M5LA4	138	C902_29.4 P180 BN180M4	139
56	2983	1.2	25.9	25300	C802_25.9 S5 M5LA4	135	C802_25.9 P180 BN180M4	136
66	2557	1.4	22.2	25100	C802_22.2 S5 M5LA4	135	C802_22.2 P180 BN180M4	136
76	2217	0.9	19.3	14100	C702_19.3 S5 M5LA4	132	C702_19.3 P180 BN180M4	133
87	1920	1.1	16.7	13800	C702_16.7 S5 M5LA4	132	C702_16.7 P180 BN180M4	133
88	1916	1.8	16.7	24400	C802_16.7 S5 M5LA4	135	C802_16.7 P180 BN180M4	136
104	1620	1.3	14.1	13900	C702_14.1 S5 M5LA4	132	C702_14.1 P180 BN180M4	133
106	1582	2.2	13.8	23700	C802_13.8 S5 M5LA4	135	C802_13.8 P180 BN180M4	136
121	1390	1.0	12.1	8420	C612_12.1 S5 M5LA4	129	C612_12.1 P180 BN180M4	130
130	1289	1.7	11.2	13800	C702_11.2 S5 M5LA4	132	C702_11.2 P180 BN180M4	133
132	1275	2.7	11.1	22900	C802_11.1 S5 M5LA4	135	C802_11.1 P180 BN180M4	136
134	1252	1.1	10.9	8360	C612_10.9 S5 M5LA4	129	C612_10.9 P180 BN180M4	130
149	1129	1.2	9.8	8400	C612_9.8 S5 M5LA4	129	C612_9.8 P180 BN180M4	130
153	1095	2.0	9.5	13600	C702_9.5 S5 M5LA4	132	C702_9.5 P180 BN180M4	133
165	1019	3.4	8.9	21900	C802_8.9 S5 M5LA4	135	C802_8.9 P180 BN180M4	136
165	1016	1.3	8.8	8300	C612_8.8 S5 M5LA4	129	C612_8.8 P180 BN180M4	130
195	860	1.6	7.5	8230	C612_7.5 S5 M5LA4	129	C612_7.5 P180 BN180M4	130
217	775	1.7	6.7	8090	C612_6.7 S5 M5LA4	129	C612_6.7 P180 BN180M4	130
233	719	2.7	6.3	13100	C702_6.3 S5 M5LA4	132	C702_6.3 P180 BN180M4	133
243	690	1.0	6.0	7550	C612_6.0 S5 M5LA4	129	C612_6.0 P180 BN180M4	130
250	673	2.8	5.9	12800	C702_5.9 S5 M5LA4	132	C702_5.9 P180 BN180M4	133
269	624	2.2	10.9	7840	C612_10.9 S5 M5SC2	129	C612_10.9 P160 BN160L2	130
298	562	2.4	9.8	7740	C612_9.8 S5 M5SC2	129	C612_9.8 P160 BN160L2	130
300	559	1.0	9.8	5190	C512_9.8 S5 M5LA4	127	C512_9.8 P160 BN160L2	127
319	526	3.2	4.6	12300	C702_4.6 S5 M5LA4	132	C702_4.6 P180 BN180M4	133
320	524	1.3	4.6	7300	C612_4.6 S5 M5LA4	129	C612_4.6 P180 BN180M4	130
331	507	2.6	8.8	7570	C612_8.8 S5 M5SC2	129	C612_8.8 P160 BN160L2	130
333	504	1.1	8.8	5160	C512_8.8 S5 M5LA4	127	C512_8.8 P160 BN160L2	127
378	444	1.1	7.8	5070	C512_7.8 S5 M5LA4	127	C512_7.8 P160 BN160L2	127
391	429	2.9	7.5	7350	C612_7.5 S5 M5SC2	129	C612_7.5 P160 BN160L2	130
395	425	1.6	3.7	7060	C612_3.7 S5 M5LA4	129	C612_3.7 P180 BN180M4	130
419	400	1.2	7.0	5010	C512_7.0 S5 M5LA4	127	C512_7.0 P160 BN160L2	127
435	386	3.1	6.7	7170	C612_6.7 S5 M5SC2	129	C612_6.7 P160 BN160L2	130
441	380	1.1	3.3	4660	C512_3.3 S5 M5LA4	127	C512_3.3 P180 BN180M4	127
488	344	1.9	6.0	6780	C612_6.0 S5 M5SC2	129	C612_6.0 P160 BN160L2	130
518	324	2.1	2.8	6700	C612_2.8 S5 M5LA4	129	C612_2.8 P180 BN180M4	130
520	323	1.3	5.6	4580	C512_5.6 S5 M5LA4	127	C512_5.6 P160 BN160L2	127
555	302	1.3	2.6	4540	C512_2.6 S5 M5LA4	127	C512_2.6 P180 BN180M4	127
643	261	2.5	4.6	6390	C612_4.6 S5 M5SC2	129	C612_4.6 P160 BN160L2	130
658	255	1.7	4.5	4420	C512_4.5 S5 M5LA4	127	C512_4.5 P160 BN160L2	127
792	212	3.1	3.7	6080	C612_3.7 S5 M5SC2	129	C612_3.7 P160 BN160L2	130
886	189	2.2	3.3	4180	C512_3.3 S5 M5LA4	127	C512_3.3 P160 BN160L2	127
1115	151	2.7	2.6	3980	C512_2.6 S5 M5LA4	127	C512_2.6 P160 BN160L2	127

## 22 kW

14.7	13266	0.9	99.8	70600	C1003_99.8 S5 M5LA4	141	C1003_99.8 P180 BN180L4	142
18.5	10560	1.1	79.4	71200	C1003_79.4 S5 M5LA4	141	C1003_79.4 P180 BN180L4	142
24.8	7869	0.9	59.2	36700	C903_59.2 S5 M5LA4	138	C903_59.2 P180 BN180L4	139
25.6	7623	1.6	57.4	70300	C1003_57.4 S5 M5LA4	141	C1003_57.4 P180 BN180L4	142
29.2	6686	1.1	50.3	37400	C903_50.3 S5 M5LA4	138	C903_50.3 P180 BN180L4	139
32	6144	2.0	46.2	68800	C1003_46.2 S5 M5LA4	141	C1003_46.2 P180 BN180L4	142

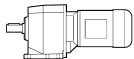

## 22 kW

$n_2$ min <sup>-1</sup>	$M_2$ Nm	S	i	$R_{n2}$ N				
40	4909	2.4	36.9	66700			C1003_ 36.9 P180 BN180L4	142
42	4766	1.1	35.1	37400			C902_ 35.1 P180 BN180L4	139
50	4013	2.3	29.6	64100			C1002_ 29.6 P180 BN180L4	142
50	3997	1.5	29.4	37100			C902_ 29.4 P180 BN180L4	139
61	3252	1.1	24.0	23700			C802_ 24.0 P180 BN180L4	136
64	3112	2.0	22.9	36400			C902_ 22.9 P180 BN180L4	139
81	2451	1.5	18.1	23300			C802_ 18.1 P180 BN180L4	136
85	2350	2.8	17.3	34900			C902_ 17.3 P180 BN180L4	139
88	2268	0.9	16.7	12400			C702_ 16.7 P180 BN180L4	133
99	2025	1.8	14.9	22900			C802_ 14.9 P180 BN180L4	136
104	1914	1.1	14.1	12700			C702_ 14.1 P180 BN180L4	133
106	1881	3.2	13.9	33700			C902_ 13.9 P180 BN180L4	139
131	1522	1.4	11.2	12900			C702_ 11.2 P180 BN180L4	133
133	1506	2.3	11.1	22100			C802_ 11.1 P180 BN180L4	136
135	1478	0.9	10.9	7580			C612_ 10.9 P180 BN180L4	130
150	1333	1.0	9.8	7710			C612_ 9.8 P180 BN180L4	130
154	1293	1.7	9.5	12800			C702_ 9.5 P180 BN180L4	133
166	1204	2.9	8.9	21300			C802_ 8.9 P180 BN180L4	136
166	1201	1.1	8.8	7660			C612_ 8.8 P180 BN180L4	130
184	1085	1.2	15.9	7710			C612_ 15.9 P180 BN180M2	130
196	1016	1.3	7.5	7690			C612_ 7.5 P180 BN180L4	130
197	1013	2.0	7.5	12700			C702_ 7.5 P180 BN180L4	133
209	956	3.5	7.0	20400			C802_ 7.0 P180 BN180L4	136
218	915	1.5	6.7	7600			C612_ 6.7 P180 BN180L4	130
251	794	2.4	5.9	12300			C702_ 5.9 P180 BN180L4	133
269	742	1.8	10.9	7460			C612_ 10.9 P180 BN180M2	130
298	669	2.0	9.8	7390			C612_ 9.8 P180 BN180M2	130
322	621	2.7	4.6	11900			C702_ 4.6 P180 BN180L4	133
323	619	1.1	4.6	6910			C612_ 4.6 P180 BN180L4	130
331	602	2.2	8.8	7250			C612_ 8.8 P180 BN180M2	130
333	599	0.9	8.8	4820			C512_ 8.8 P180 BN180M2	127
378	528	1.0	7.8	4770			C512_ 7.8 P180 BN180M2	127
391	510	2.4	7.5	7080			C612_ 7.5 P180 BN180M2	130
397	502	1.3	3.7	6740			C612_ 3.7 P180 BN180L4	130
419	476	1.1	7.0	4740			C512_ 7.0 P180 BN180M2	127
435	459	2.6	6.7	6920			C612_ 6.7 P180 BN180M2	130
444	449	0.9	3.3	4350			C512_ 3.3 P180 BN180L4	127
488	409	1.6	6.0	6530			C612_ 6.0 P180 BN180M2	130
520	384	1.1	5.6	4310			C512_ 5.6 P180 BN180M2	127
521	383	1.7	2.8	6450			C612_ 2.8 P180 BN180L4	130
559	357	1.1	2.6	4290			C512_ 2.6 P180 BN180L4	127
643	310	2.1	4.6	6200			C612_ 4.6 P180 BN180M2	130
658	303	1.4	4.5	4210			C512_ 4.5 P180 BN180M2	127
792	252	2.6	3.7	5930			C612_ 3.7 P180 BN180M2	130
886	225	1.9	3.3	4030			C512_ 3.3 P180 BN180M2	127
1039	192	3.5	2.8	5560			C612_ 2.8 P180 BN180M2	130
1115	179	2.2	2.6	3860			C512_ 2.6 P180 BN180M2	127



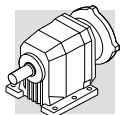

## 30 kW

21.2	12584	1.0	69.4	61300			C1003_ 69.4 P200 BN200L4	142
25.6	10395	1.2	57.4	62200			C1003_ 57.4 P200 BN200L4	142
32	8379	1.4	46.2	62300			C1003_ 46.2 P200 BN200L4	142
37	7142	1.0	39.4	31900			C903_ 39.4 P200 BN200L4	139
50	5472	1.7	29.6	59800			C1002_ 29.6 P200 BN200L4	142
50	5450	1.1	29.4	32600			C902_ 29.4 P200 BN200L4	139
64	4243	1.5	22.9	32900			C902_ 22.9 P200 BN200L4	139
66	4119	2.4	22.2	57700			C1002_ 22.2 P200 BN200L4	142
79	3459	1.8	18.7	32600			C902_ 18.7 P200 BN200L4	139
79	3456	3.1	18.7	56000			C1002_ 18.7 P200 BN200L4	142
99	2761	1.3	14.9	20600			C802_ 14.9 P200 BN200L4	136
106	2566	2.4	13.9	31500			C902_ 13.9 P200 BN200L4	139
122	2225	1.7	12.0	20500			C802_ 12.0 P200 BN200L4	136



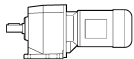

## 30 kW

$n_2$ min <sup>-1</sup>	$M_2$ Nm	S	i	$R_{n2}$ N			 IEC		
131	2079	2.7	11.2	30600			C902_ 11.2	P200 BN200L4	139
153	1778	2.1	9.6	20100			C802_ 9.6	P200 BN200L4	136
154	1763	1.2	9.5	11000			C702_ 9.5	P200 BN200L4	133
184	1482	1.4	8.0	11600			C702_ 8.0	P200 BN200L4	133
193	1412	2.4	7.6	19500			C802_ 7.6	P200 BN200L4	136
209	1303	2.6	7.0	19300			C802_ 7.0	P200 BN200L4	136
235	1158	1.7	6.3	11500			C702_ 6.3	P200 BN200L4	133
241	1131	2.8	6.1	18900			C802_ 6.1	P200 BN200L4	136
261	1044	3.0	5.6	18600			C802_ 5.6	P200 BN200L4	136
322	846	2.0	4.6	11000			C702_ 4.6	P200 BN200L4	133

## 37 kW



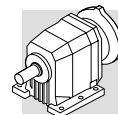

25.8	12734	0.9	57.4	55300			C1003_ 57.4	P225 BN225S4	142
32	10264	1.2	46.2	56600			C1003_ 46.2	P225 BN225S4	142
40	8201	1.4	36.9	57000			C1003_ 36.9	P225 BN225S4	142
60	5631	1.2	24.8	29500			C902_ 24.8	P225 BN225S4	139
61	5467	2.0	24.1	55200			C1002_ 24.1	P225 BN225S4	142
79	4237	1.5	18.7	30100			C902_ 18.7	P225 BN225S4	139
79	4234	2.5	18.7	53600			C1002_ 18.7	P225 BN225S4	142
89	3779	0.9	16.7	18500			C802_ 16.7	P225 BN225S4	136
107	3143	1.9	13.9	29700			C902_ 13.9	P225 BN225S4	139
108	3122	1.1	13.8	18800			C802_ 13.8	P225 BN225S4	136
123	2726	1.4	12.0	18800			C802_ 12.0	P225 BN225S4	136
132	2546	2.2	11.2	29100			C902_ 11.2	P225 BN225S4	139
154	2178	1.7	9.6	18800			C802_ 9.6	P225 BN225S4	136
164	2046	2.5	9.0	28300			C902_ 9.0	P225 BN225S4	139
194	1730	2.0	7.6	18500			C802_ 7.6	P225 BN225S4	136
202	1661	2.9	7.3	27400			C902_ 7.3	P225 BN225S4	139
242	1386	2.3	6.1	18000			C802_ 6.1	P225 BN225S4	136
264	1271	3.5	5.6	26100			C902_ 5.6	P225 BN225S4	139
286	1173	3.7	5.2	25700			C902_ 5.2	P225 BN225S4	139

## 45 kW

32	12483	1.0	46.2	50200			C1003_ 46.2	P225 BN225M4	142
40	9974	1.2	36.9	51900			C1003_ 36.9	P225 BN225M4	142
50	8153	1.1	29.6	51900			C1002_ 29.6	P225 BN225M4	142
65	6322	1.0	22.9	26400			C902_ 22.9	P225 BN225M4	139
67	6137	1.6	22.2	51700			C1002_ 22.2	P225 BN225M4	142
79	5153	1.2	18.7	27200			C902_ 18.7	P225 BN225M4	139
79	5149	2.1	18.7	51000			C1002_ 18.7	P225 BN225M4	142
107	3822	1.6	13.9	27600			C902_ 13.9	P225 BN225M4	139
108	3797	0.9	13.8	16700			C802_ 13.8	P225 BN225M4	136
123	3315	1.1	12.0	17000			C802_ 12.0	P225 BN225M4	136
132	3097	1.8	11.2	27400			C902_ 11.2	P225 BN225M4	139
154	2649	1.4	9.6	17300			C802_ 9.6	P225 BN225M4	136
164	2488	2.1	9.0	26900			C902_ 9.0	P225 BN225M4	139
194	2104	1.6	7.6	17300			C802_ 7.6	P225 BN225M4	136
202	2020	2.4	7.3	26300			C902_ 7.3	P225 BN225M4	139
262	1556	2.0	5.6	17000			C802_ 5.6	P225 BN225M4	136
264	1546	2.8	5.6	25200			C902_ 5.6	P225 BN225M4	139
279	1464	2.9	5.2	25200			C902_ 5.2	P225 BN225M4	139

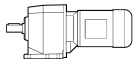

## 55 kW

$n_2$ min <sup>-1</sup>	$M_2$ Nm	S	i	$R_{n2}$ N					
40	12191	1.0	36.9	45400			C1003_ 36.9	P250 BN250M4	142
50	9965	0.9	29.6	46700			C1002_ 29.6	P250 BN250M4	142
61	8126	1.3	24.1	47500			C1002_ 24.1	P250 BN250M4	142
79	6298	1.0	18.7	22200			C902_ 18.7	P250 BN250M4	139
79	6294	1.7	18.7	47700			C1002_ 18.7	P250 BN250M4	142
107	4672	1.3	13.9	24900			C902_ 13.9	P250 BN250M4	139
110	4549	2.1	13.5	46500			C1002_ 13.5	P250 BN250M4	142
135	3686	2.4	10.9	45400			C1002_ 10.9	P250 BN250M4	142
164	3050	2.7	9.0	44100			C1002_ 9.0	P250 BN250M4	142
164	3041	1.7	9.0	25200			C902_ 9.0	P250 BN250M4	139
202	2468	2.0	7.3	24900			C902_ 7.3	P250 BN250M4	139
209	2383	3.2	7.1	42300			C1002_ 7.1	P250 BN250M4	142
264	1889	2.3	5.6	24200			C902_ 5.6	P250 BN250M4	139
286	1744	2.5	5.2	24000			C902_ 5.2	P250 BN250M4	139

## 75 kW

62	11044	1.0	24.1	38100			C1002_ 24.1	P280 BN280S4	142
67	10194	1.0	22.2	40000			C1002_ 22.2	P280 BN280S4	142
73	9266	1.2	20.2	40500			C1002_ 20.2	P280 BN280S4	142
80	8553	1.3	18.7	41100			C1002_ 18.7	P280 BN280S4	142
90	7552	1.3	16.5	41400			C1002_ 16.5	P280 BN280S4	142
98	6971	1.4	15.2	41800			C1002_ 15.2	P280 BN280S4	142
110	6182	1.5	13.5	41700			C1002_ 13.5	P280 BN280S4	142
119	5707	1.6	12.5	41800			C1002_ 12.5	P280 BN280S4	142
136	5010	1.8	10.9	41500			C1002_ 10.9	P280 BN280S4	142
147	4624	1.9	10.1	41400			C1002_ 10.1	P280 BN280S4	142
164	4146	2.0	9.0	40900			C1002_ 9.0	P280 BN280S4	142
178	3827	2.1	8.4	40600			C1002_ 8.4	P280 BN280S4	142
210	3238	2.4	7.1	39700			C1002_ 7.1	P280 BN280S4	142
228	2989	2.5	6.5	39300			C1002_ 6.5	P280 BN280S4	142
278	2444	2.8	5.3	38100			C1002_ 5.3	P280 BN280S4	142
302	2256	3.0	4.9	37600			C1002_ 4.9	P280 BN280S4	142

## 90 kW

73	11119	1.0	20.2	30600			C1002_ 20.2	P280 BN280M4	142
80	10264	1.0	18.7	35500			C1002_ 18.7	P280 BN280M4	142
90	9062	1.1	16.5	37100			C1002_ 16.5	P280 BN280M4	142
98	8365	1.2	15.2	37800			C1002_ 15.2	P280 BN280M4	142
110	7419	1.3	13.5	38100			C1002_ 13.5	P280 BN280M4	142
119	6848	1.4	12.5	38500			C1002_ 12.5	P280 BN280M4	142
136	6012	1.5	10.9	38600			C1002_ 10.9	P280 BN280M4	142
147	5549	1.6	10.1	38700			C1002_ 10.1	P280 BN280M4	142
164	4975	1.7	9.0	38500			C1002_ 9.0	P280 BN280M4	142
178	4592	1.8	8.4	38400			C1002_ 8.4	P280 BN280M4	142
210	3886	2.0	7.1	37800			C1002_ 7.1	P280 BN280M4	142
228	3587	2.1	6.5	37600			C1002_ 6.5	P280 BN280M4	142
278	2933	2.4	5.3	36600			C1002_ 5.3	P280 BN280M4	142
302	2707	2.5	4.9	36300			C1002_ 4.9	P280 BN280M4	142

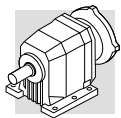

# C 11



# 100 Nm

25 - DATI TECNICI  
RIDUTTORI



25 - GEARBOX RATING  
CHARTS

25 - GETRIEBE  
AUSWAHLTABELLEN

25 - DONNEES TECHNIQUES  
REDUCTEURS

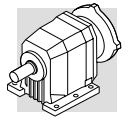
	i	n <sub>1</sub> = 2800 min <sup>-1</sup>					n <sub>1</sub> = 1400 min <sup>-1</sup>					
		n <sub>2</sub> min <sup>-1</sup>	M <sub>n2</sub> Nm	P <sub>n1</sub> kW	R <sub>n1</sub> N	R <sub>n2</sub> N	n <sub>2</sub> min <sup>-1</sup>	M <sub>n2</sub> Nm	P <sub>n1</sub> kW	R <sub>n1</sub> N	R <sub>n2</sub> N	
C 11 2_2.8	2.8	1011	30	3.3	750	600	505	37	2.1	990	790	113
C 11 2_3.7	3.7	767	34	2.9	720	610	384	42	1.8	960	800	
C 11 2_4.9	4.9	575	38	2.4	710	640	287	48	1.5	880	800	
C 11 2_6.2	6.2	449	42	2.1	650	660	225	53	1.3	810	830	
C 11 2_6.9	6.9	408	43	1.9	1120	1170	204	54	1.2	1300	1480	
C 11 2_7.6	7.6	367	45	1.8	1140	1220	184	56	1.1	1300	1540	
C 11 2_9.1	9.1	309	48	1.6	1120	1280	155	61	1.0	1300	1610	
C 11 2_10.1	10.1	278	49	1.5	1150	1340	139	63	0.97	1300	1680	
C 11 2_12.1	12.1	232	53	1.4	1120	1410	116	67	0.86	1300	1780	
C 11 2_13.4	13.4	209	55	1.3	1140	1460	104	70	0.81	1300	1840	
C 11 2_15.5	15.5	181	58	1.2	1100	1520	90	74	0.74	1300	1880	
C 11 2_17.2	17.2	163	60	1.1	1130	1590	82	76	0.68	1300	2000	
C 11 2_18.6	18.6	151	63	1.0	1090	1570	75	79	0.66	1300	1990	
C 11 2_20.6	20.6	136	65	0.97	1110	1670	68	82	0.61	1300	2000	
C 11 2_22.8	22.8	123	67	0.90	1080	1700	61	85	0.57	1300	2000	
C 11 2_25.4	25.4	110	69	0.84	1110	1800	55	88	0.54	1300	2000	
C 11 2_29.5	29.5	95	74	0.77	1060	1810	47	93	0.49	1300	2000	
C 11 2_32.8	32.8	85	75	0.71	1090	1970	43	90	0.42	1300	2000	
C 11 2_33.4	33.4	84	77	0.71	1030	1890	42	100	0.46	1286	2000	
C 11 2_37.0	37.0	76	79	0.66	1070	2000	38	90	0.38	1300	2000	
C 11 2_42.9	42.9	65	84	0.60	1010	2000	33	100	0.36	1300	2000	
C 11 2_47.6	47.6	59	85	0.55	1050	2000	29.4	90	0.29	1300	2000	
C 11 2_49.7	49.7	56	88	0.55	990	2000	28.2	100	0.31	1300	2000	
C 11 2_55.2	55.2	51	89	0.50	1030	2000	25.4	90	0.25	1300	2000	
C 11 2_59.6	59.6	47	78	0.40	1060	2000	23.5	82	0.21	1300	2000	
C 11 2_66.2	66.2	42	86	0.40	1060	2000	21.2	90	0.21	1300	2000	



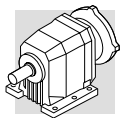

	i	$n_1 = 900 \text{ min}^{-1}$					$n_1 = 500 \text{ min}^{-1}$					
		$n_2$ $\text{min}^{-1}$	$M_{n2}$ Nm	$P_{n1}$ kW	$R_{n1}$ N	$R_{n2}$ N	$n_2$ $\text{min}^{-1}$	$M_{n2}$ Nm	$P_{n1}$ kW	$R_{n1}$ N	$R_{n2}$ N	
C 11 2_2.8	2.8	325	43	1.5	1140	910	187	53	1.1	1300	1080	113
C 11 2_3.7	3.7	247	49	1.3	1090	920	137	60	0.91	1300	1100	
C 11 2_4.9	4.9	185	55	1.1	1050	960	103	67	0.76	1280	1160	
C 11 2_6.2	6.2	144	61	0.97	960	980	80	70	0.62	1300	1390	
C 11 2_6.9	6.9	131	62	0.90	1300	1720	73	76	0.61	1300	2000	
C 11 2_7.6	7.6	118	65	0.85	1300	1780	66	79	0.57	1300	2000	
C 11 2_9.1	9.1	99	70	0.77	1300	1870	55	85	0.52	1300	2000	
C 11 2_10.1	10.1	89	72	0.71	1300	1950	50	88	0.48	1300	2000	
C 11 2_12.1	12.1	75	78	0.64	1300	2000	41	95	0.43	1300	2000	
C 11 2_13.4	13.4	67	81	0.60	1300	2000	37	90	0.37	1300	2000	
C 11 2_15.5	15.5	58	86	0.55	1300	2000	32	99	0.35	1300	2000	
C 11 2_17.2	17.2	52	88	0.51	1300	2000	29.1	90	0.29	1300	2000	
C 11 2_18.6	18.6	48	91	0.49	1300	2000	26.9	99	0.29	1300	2000	
C 11 2_20.6	20.6	44	89	0.43	1300	2000	24.2	89	0.24	1300	2000	
C 11 2_22.8	22.8	39	99	0.43	1300	2000	21.9	99	0.24	1300	2000	
C 11 2_25.4	25.4	35	89	0.35	1300	2000	19.7	89	0.19	1300	2000	
C 11 2_29.5	29.5	30	100	0.34	1300	2000	16.9	100	0.19	1300	2000	
C 11 2_32.8	32.8	27.5	90	0.27	1300	2000	15.3	90	0.15	1300	2000	
C 11 2_33.4	33.4	27.0	100	0.30	1300	2000	15.0	100	0.17	1300	2000	
C 11 2_37.0	37.0	24.3	90	0.24	1300	2000	13.5	90	0.13	1300	2000	
C 11 2_42.9	42.9	21.0	100	0.23	1300	2000	11.7	100	0.13	1300	2000	
C 11 2_47.6	47.6	18.9	90	0.19	1300	2000	10.5	90	0.10	1300	2000	
C 11 2_49.7	49.7	18.1	100	0.20	1300	2000	10.1	100	0.11	1300	2000	
C 11 2_55.2	55.2	16.3	90	0.16	1300	2000	9.1	90	0.09	1300	2000	
C 11 2_59.6	59.6	15.1	85	0.14	1300	2000	8.4	88	0.08	1300	2000	
C 11 2_66.2	66.2	13.6	90	0.13	1300	2000	7.6	90	0.07	1300	2000	



# C 21

# 200 Nm

	i	$n_1 = 2800 \text{ min}^{-1}$					$n_1 = 1400 \text{ min}^{-1}$					
		$n_2$ $\text{min}^{-1}$	$M_{n2}$ Nm	$P_{n1}$ kW	$R_{n1}$ N	$R_{n2}$ N	$n_2$ $\text{min}^{-1}$	$M_{n2}$ Nm	$P_{n1}$ kW	$R_{n1}$ N	$R_{n2}$ N	
C 21 2_2.7	2.7	1029	65	7.4	—	1150	515	80	4.5	—	1460	116
C 21 2_3.7	3.7	755	70	5.8	—	1290	377	90	3.7	—	1610	
C 21 2_4.8	4.8	587	80	5.2	—	1370	294	100	3.2	—	1730	
C 21 2_6.1	6.1	460	85	4.3	—	1500	230	105	2.7	—	1900	
C 21 2_6.4	6.4	439	100	4.8	960	1510	219	125	3.0	1230	1910	
C 21 2_7.1	7.1	395	105	4.6	1090	1570	198	130	2.8	1420	1990	
C 21 2_8.7	8.7	323	110	3.9	1030	1680	161	140	2.5	1260	2110	
C 21 2_9.6	9.6	290	115	3.7	1160	1750	145	145	2.3	1460	2200	
C 21 2_11.2	11.2	251	125	3.5	930	1790	125	155	2.1	1220	2280	
C 21 2_12.4	12.4	226	125	3.1	1160	1900	113	160	2.0	1420	2380	
C 21 2_14.3	14.3	196	135	2.9	870	1950	98	170	1.8	1100	2460	
C 21 2_15.8	15.8	177	140	2.7	1030	2030	88	175	1.7	1320	2570	
C 21 2_18.0	18.0	155	145	2.5	840	2120	78	185	1.6	1010	2650	
C 21 2_20.0	20.0	140	150	2.3	1000	2210	70	190	1.5	1250	2770	
C 21 2_21.9	21.9	128	155	2.2	800	2250	64	200	1.4	940	2810	
C 21 2_24.3	24.3	115	160	2.0	980	2350	58	200	1.3	1250	2970	
C 21 2_26.7	26.7	105	170	2.0	660	2380	52	200	1.2	1040	3090	
C 21 2_29.6	29.6	95	175	1.8	850	2490	47	200	1.0	1350	3270	
C 21 2_33.1	33.1	85	180	1.7	550	2570	42	200	0.93	1100	3420	
C 21 2_36.8	36.8	76	185	1.6	750	2690	38	200	0.84	1400	3610	
C 21 2_39.0	39.0	72	165	1.3	860	2880	36	170	0.67	1630	3880	
C 21 2_43.3	43.3	65	185	1.3	830	2910	32	190	0.68	1610	3950	
C 21 2_49.3	49.3	57	135	0.85	1320	3410	28.4	140	0.44	1770	4490	
C 21 2_54.7	54.7	51	150	0.85	1320	3470	25.6	155	0.44	1770	4600	
C 21 2_57.0	57.0	49	110	0.60	1410	3780	24.6	115	0.31	1830	4920	
C 21 2_63.3	63.3	44	125	0.61	1400	3860	22.1	130	0.32	1820	5000	
C 21 3_58.8	58.8	48	180	0.96	880	3390	23.8	190	0.24	1240	4510	
C 21 3_65.3	65.3	43	200	0.97	880	3440	21.4	200	0.48	1270	4670	
C 21 3_74.4	74.4	38	200	0.85	960	3630	18.8	200	0.42	1300	4920	
C 21 3_82.6	82.6	34	200	0.76	1010	3820	16.9	200	0.38	1300	5000	
C 21 3_90.2	90.2	31	200	0.70	1050	3960	15.5	200	0.35	1300	5000	
C 21 3_100.2	100.2	28.0	200	0.63	1090	4160	14.0	200	0.31	1300	5000	
C 21 3_110.0	110.0	25.5	200	0.57	1130	4320	12.7	200	0.29	1300	5000	
C 21 3_122.2	122.2	22.9	200	0.52	1160	4540	11.5	200	0.26	1300	5000	
C 21 3_136.5	136.6	20.5	200	0.46	1190	4740	10.3	200	0.23	1300	5000	
C 21 3_151.7	151.7	18.5	200	0.42	1220	4980	9.2	200	0.21	1300	5000	
C 21 3_160.7	160.7	17.4	195	0.38	1240	5000	8.7	200	0.20	1300	5000	
C 21 3_178.5	178.5	15.7	200	0.35	1260	5000	7.8	200	0.18	1300	5000	
C 21 3_203.2	203.2	13.8	160	0.25	1300	5000	6.9	165	0.13	1300	5000	
C 21 3_225.8	225.8	12.4	180	0.25	1300	5000	6.2	185	0.13	1300	5000	
C 21 3_235.0	235.0	11.9	130	0.17	1300	5000	6.0	140	0.09	1300	5000	
C 21 3_261.0	261.0	10.7	145	0.18	1300	5000	5.4	155	0.09	1300	5000	

(-) Interpellare il ns. servizio tecnico comunicando i dati relativi al carico radiale (senso di rotazione, orientamento, posizione)  
 (-) Contact our technical service department advising radial load data (rotation direction, orientation, position)  
 (-) Nehmen Sie bitte Kontakt mit unserem Applikationsdienst und Querkraftsdaten angeben (Drehrichtung, Orientierung, Anordnung)  
 (-) Consulter notre service technique en donnant les détails concernant la charge radiale (sens de rotation, indexage, position)

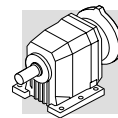

	i	n <sub>1</sub> = 900 min <sup>-1</sup>					n <sub>1</sub> = 500 min <sup>-1</sup>					
		n <sub>2</sub> min <sup>-1</sup>	M <sub>n2</sub> Nm	P <sub>n1</sub> kW	R <sub>n1</sub> N	R <sub>n2</sub> N	n <sub>2</sub> min <sup>-1</sup>	M <sub>n2</sub> Nm	P <sub>n1</sub> kW	R <sub>n1</sub> N	R <sub>n2</sub> N	
C 21 2_2.7	2.7	331	95	3.5	—	1670	184	100	2.0	400	2150	116
C 21 2_3.7	3.7	243	105	2.8	—	1850	135	105	1.6	800	2430	
C 21 2_4.8	4.8	189	105	2.2	170	2090	105	105	1.2	1200	2710	
C 21 2_6.1	6.1	148	110	1.8	200	2290	82	116	1.0	980	2930	
C 21 2_6.4	6.4	141	145	2.3	1420	2220	78	175	1.5	1760	2700	
C 21 2_7.1	7.1	127	150	2.1	1650	2310	71	180	1.4	2060	2820	
C 21 2_8.7	8.7	104	165	1.9	1410	2430	58	200	1.3	1730	2960	
C 21 2_9.6	9.6	93	170	1.7	1650	2530	52	200	1.1	2130	3130	
C 21 2_11.2	11.2	81	180	1.6	1400	2640	45	200	0.99	2060	3330	
C 21 2_12.4	12.4	73	185	1.5	1650	2760	40	200	0.89	2200	3520	
C 21 2_14.3	14.3	63	195	1.4	1310	2860	35	200	0.77	2200	3730	
C 21 2_15.8	15.8	57	200	1.3	1580	2990	32	200	0.70	2200	3920	
C 21 2_18.0	18.0	50	200	1.1	1420	3170	27.7	200	0.61	2200	4140	
C 21 2_20.0	20.0	45	200	0.99	1750	3340	25.0	200	0.55	2200	4350	
C 21 2_21.9	21.9	41	200	0.91	1590	3460	22.9	200	0.50	2200	4500	
C 21 2_24.3	24.3	37	200	0.82	1900	3650	20.6	200	0.45	2200	4720	
C 21 2_26.7	26.7	34	200	0.74	1700	3790	18.7	200	0.41	2200	4900	
C 21 2_29.6	29.6	30	200	0.67	1980	3990	16.9	200	0.37	2200	5000	
C 21 2_33.1	33.1	27.2	200	0.60	1750	4170	15.1	200	0.33	2200	5000	
C 21 2_36.8	36.8	24.5	200	0.54	1990	4390	13.6	200	0.30	2200	5000	
C 21 2_39.0	39.0	23.1	170	0.43	2020	4680	12.8	170	0.24	2200	5000	
C 21 2_43.3	43.3	20.8	190	0.44	2020	4770	11.6	190	0.24	2200	5000	
C 21 2_49.3	49.3	18.3	145	0.29	2080	5000	10.1	155	0.17	2200	5000	
C 21 2_54.7	54.7	16.4	160	0.29	2090	5000	9.1	170	0.17	2200	5000	
C 21 2_57.0	57.0	15.8	120	0.21	2140	5000	8.8	125	0.12	2200	5000	
C 21 2_63.3	63.3	14.2	135	0.21	2140	5000	7.9	140	0.12	2200	5000	
C 21 3_58.8	58.8	15.3	200	0.34	1300	5000	8.5	200	0.19	1300	5000	
C 21 3_65.3	65.3	13.8	200	0.31	1300	5000	7.7	200	0.17	1300	5000	
C 21 3_74.4	74.4	12.1	200	0.27	1300	5000	6.7	200	0.15	1300	5000	
C 21 3_82.6	82.6	10.9	200	0.25	1300	5000	6.1	200	0.14	1300	5000	
C 21 3_90.2	90.2	10.0	200	0.22	1300	5000	5.5	200	0.12	1300	5000	
C 21 3_100.2	100.2	9.0	200	0.20	1300	5000	5.0	200	0.11	1300	5000	
C 21 3_110.0	110.0	8.2	200	0.18	1300	5000	4.5	200	0.10	1300	5000	
C 21 3_122.2	122.2	7.4	200	0.17	1300	5000	4.1	200	0.09	1300	5000	
C 21 3_136.5	136.6	6.6	200	0.15	1300	5000	3.7	200	0.08	1300	5000	
C 21 3_151.7	151.7	5.9	200	0.13	1300	5000	3.3	200	0.07	1300	5000	
C 21 3_160.7	160.7	5.6	200	0.13	1300	5000	3.1	200	0.07	1300	5000	
C 21 3_178.5	178.5	5.0	200	0.11	1300	5000	2.8	200	0.06	1300	5000	
C 21 3_203.2	203.2	4.4	170	0.08	1300	5000	2.5	180	0.05	1300	5000	
C 21 3_225.8	225.8	4.0	195	0.09	1300	5000	2.2	200	0.05	1300	5000	
C 21 3_235.0	235.0	3.8	140	0.06	1300	5000	2.1	150	0.04	1300	5000	
C 21 3_261.0	261.0	3.4	160	0.06	1300	5000	1.9	165	0.04	1300	5000	

(-) Interpellare il ns. servizio tecnico comunicando i dati relativi al carico radiale (senso di rotazione, orientamento, posizione)

(-) Contact our technical service department advising radial load data (rotation direction, orientation, position)

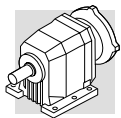

(-) Nehmen Sie bitte Kontakt mit unserem Applikationsdienst und Querkraftsdaten angeben (Drehrichtung, Orientierung, Anordnung)

(-) Consulter notre service technique en donnant les détails concernant la charge radiale (sens de rotation, indexage, position)





# C 31

# 300 Nm

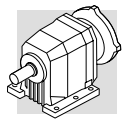
	i	$n_1 = 2800 \text{ min}^{-1}$					$n_1 = 1400 \text{ min}^{-1}$					
		$n_2$ $\text{min}^{-1}$	$M_{n2}$ Nm	$P_{n1}$ kW	$R_{n1}$ N	$R_{n2}$ N	$n_2$ $\text{min}^{-1}$	$M_{n2}$ Nm	$P_{n1}$ kW	$R_{n1}$ N	$R_{n2}$ N	
C 31 2_2.9	2.9	972	105	11.3	670	1710	486	130	7.0	940	2170	119
C 31 2_3.7	3.7	749	120	9.9	560	1830	374	150	6.2	750	2310	
C 31 2_5.0	5.0	566	135	8.4	470	1990	283	155	4.8	1100	2600	
C 31 2_6.3	6.3	447	150	7.4	300	2130	224	155	3.8	1450	2890	
C 31 2_6.5	6.5	434	155	7.4	1860	2270	217	195	4.7	2200	2870	
C 31 2_7.2	7.2	391	160	6.9	1890	2370	196	200	4.3	2200	2990	
C 31 2_8.4	8.4	335	170	6.3	1870	2480	167	215	4.0	2200	3110	
C 31 2_9.3	9.3	301	175	5.8	1910	2580	151	220	3.7	2200	3260	
C 31 2_11.1	11.1	252	190	5.3	1880	2700	126	240	3.3	2200	3400	
C 31 2_12.3	12.3	227	195	4.9	1910	2820	114	245	3.1	2200	3560	
C 31 2_14.0	14.0	199	205	4.5	1880	2930	100	260	2.9	2200	3680	
C 31 2_15.6	15.6	180	215	4.3	1900	3030	90	270	2.7	2200	3820	
C 31 2_18.1	18.1	155	225	3.8	1870	3170	77	285	2.4	2200	3990	
C 31 2_20.1	20.1	139	235	3.6	1900	3290	70	295	2.3	2200	4160	
C 31 2_22.6	22.6	124	245	3.3	1850	3410	62	300	2.0	2200	4330	
C 31 2_25.1	25.1	111	250	3.1	1890	3560	56	300	1.8	2200	4570	
C 31 2_26.8	26.8	105	260	3.0	1840	3600	52	300	1.7	2200	4680	
C 31 2_29.8	29.8	94	265	2.7	1880	3770	47	300	1.6	2200	4920	
C 31 2_32.5	32.5	86	275	2.6	1760	3850	43	300	1.4	2200	5090	
C 31 2_36.1	36.1	78	280	2.4	1870	4030	39	300	1.3	2200	5350	
C 31 2_40.7	40.7	69	295	2.2	1620	4160	34	300	1.1	2200	5500	
C 31 2_45.3	45.3	62	300	2.0	1860	4360	31	300	1.0	2200	5500	
C 31 2_47.2	47.2	59	300	2.0	1610	4420	29.7	300	0.98	2200	5500	
C 31 2_52.4	52.4	53	300	1.8	1860	4650	26.7	300	0.88	2200	5500	
C 31 2_60.2	60.2	47	180	0.92	2030	5500	23.3	190	0.49	2200	5500	
C 31 2_66.8	66.8	42	205	0.95	2020	5500	21.0	215	0.50	2200	5500	
C 31 3_74.3	74.3	38	275	1.2	790	5500	18.8	300	0.64	1170	5500	
C 31 3_82.6	82.6	34	300	1.1	820	5500	17.0	300	0.57	1240	5500	
C 31 3_93.0	93.0	30	290	0.98	940	5500	15.1	300	0.51	1300	5500	
C 31 3_103.3	103.3	27.1	300	0.92	980	5500	13.6	300	0.46	1300	5500	
C 31 3_110.2	110.2	25.4	300	0.86	1010	5500	12.7	300	0.43	1300	5500	
C 31 3_122.4	122.4	22.9	300	0.77	1060	5500	11.4	300	0.39	1300	5500	
C 31 3_133.6	133.6	21.0	300	0.71	1090	5500	10.5	300	0.35	1300	5500	
C 31 3_148.4	148.4	18.9	300	0.64	1130	5500	9.4	300	0.32	1300	5500	
C 31 3_167.5	167.5	16.7	300	0.56	1170	5500	8.4	300	0.28	1300	5500	
C 31 3_186.0	186.0	15.1	300	0.51	1200	5500	7.5	300	0.25	1300	5500	
C 31 3_194.1	194.1	14.4	280	0.45	1230	5500	7.2	295	0.24	1300	5500	
C 31 3_215.6	215.6	13.0	300	0.44	1240	5500	6.5	300	0.22	1300	5500	
C 31 3_247.3	247.3	11.3	215	0.27	1300	5500	5.7	225	0.14	1300	5500	
C 31 3_274.7	274.7	10.2	240	0.28	1300	5500	5.1	255	0.15	1300	5500	





	i	$n_1 = 900 \text{ min}^{-1}$					$n_1 = 500 \text{ min}^{-1}$					
		$n_2$ $\text{min}^{-1}$	$M_{n2}$ Nm	$P_{n1}$ kW	$R_{n1}$ N	$R_{n2}$ N	$n_2$ $\text{min}^{-1}$	$M_{n2}$ Nm	$P_{n1}$ kW	$R_{n1}$ N	$R_{n2}$ N	
C 31 2_2.9	2.9	313	150	5.2	1120	2510	174	155	3.0	2200	3220	119
C 31 2_3.7	3.7	241	155	4.1	1570	2790	134	175	2.6	2200	3480	
C 31 2_5.0	5.0	182	162	3.2	1870	3120	101	198	2.2	2200	3790	
C 31 2_6.3	6.3	144	178	2.8	1730	3350	80	200	1.8	2200	4180	
C 31 2_6.5	6.5	140	225	3.5	2200	3330	78	275	2.3	2200	4040	
C 31 2_7.2	7.2	126	235	3.3	2200	3450	70	285	2.2	2200	4200	
C 31 2_8.4	8.4	108	250	3.0	2200	3600	60	300	2.0	2200	4410	
C 31 2_9.3	9.3	97	260	2.8	2200	3750	54	300	1.8	2200	4640	
C 31 2_11.1	11.1	81	280	2.5	2200	3930	45	300	1.5	2200	4990	
C 31 2_12.3	12.3	73	285	2.3	2200	4120	41	300	1.3	2200	5250	
C 31 2_14.0	14.0	64	300	2.1	2200	4270	36	300	1.2	2200	5500	
C 31 2_15.6	15.6	58	300	1.9	2200	4500	32	300	1.1	2200	5500	
C 31 2_18.1	18.1	50	300	1.6	2200	4780	27.7	300	0.91	2200	5500	
C 31 2_20.1	20.1	45	300	1.5	2200	5030	24.9	300	0.82	2200	5500	
C 31 2_22.6	22.6	40	300	1.3	2200	5270	22.1	300	0.73	2200	5500	
C 31 2_25.1	25.1	36	300	1.2	2200	5500	19.9	300	0.66	2200	5500	
C 31 2_26.8	26.8	34	300	1.1	2200	5500	18.7	300	0.62	2200	5500	
C 31 2_29.8	29.8	30	300	1.0	2200	5500	16.8	300	0.56	2200	5500	
C 31 2_32.5	32.5	27.7	300	0.92	2200	5500	15.4	300	0.51	2200	5500	
C 31 2_36.1	36.1	24.9	300	0.82	2200	5500	13.9	300	0.46	2200	5500	
C 31 2_40.7	40.7	22.1	300	0.73	2200	5500	12.3	300	0.41	2200	5500	
C 31 2_45.3	45.3	19.9	300	0.66	2200	5500	11.0	300	0.37	2200	5500	
C 31 2_47.2	47.2	19.1	300	0.63	2200	5500	10.6	300	0.35	2200	5500	
C 31 2_52.4	52.4	17.2	300	0.57	2200	5500	9.5	300	0.32	2200	5500	
C 31 2_60.2	60.2	15.0	200	0.33	2200	5500	8.3	205	0.19	2200	5500	
C 31 2_66.8	66.8	13.5	220	0.33	2200	5500	7.5	230	0.19	2200	5500	
C 31 3_74.3	74.3	12.1	300	0.41	1300	5500	6.7	300	0.23	1300	5500	
C 31 3_82.6	82.6	10.9	300	0.37	1300	5500	6.1	300	0.20	1300	5500	
C 31 3_93.0	93.0	9.7	300	0.33	1300	5500	5.4	300	0.18	1300	5500	
C 31 3_103.3	103.3	8.7	300	0.29	1300	5500	4.8	300	0.16	1300	5500	
C 31 3_110.2	110.2	8.2	300	0.28	1300	5500	4.5	300	0.15	1300	5500	
C 31 3_122.4	122.4	7.4	300	0.25	1300	5500	4.1	300	0.14	1300	5500	
C 31 3_133.6	133.6	6.7	300	0.23	1300	5500	3.7	300	0.13	1300	5500	
C 31 3_148.4	148.4	6.1	300	0.20	1300	5500	3.4	300	0.11	1300	5500	
C 31 3_167.5	167.5	5.4	300	0.18	1300	5500	3.0	300	0.10	1300	5500	
C 31 3_186.0	186.0	4.8	300	0.16	1300	5500	2.7	300	0.09	1300	5500	
C 31 3_194.1	194.1	4.6	300	0.16	1300	5500	2.6	300	0.09	1300	5500	
C 31 3_215.6	215.6	4.2	300	0.14	1300	5500	2.3	300	0.08	1300	5500	
C 31 3_247.3	247.3	3.6	235	0.10	1300	5500	2.0	245	0.06	1300	5500	
C 31 3_274.7	274.7	3.3	260	0.10	1300	5500	1.8	275	0.06	1300	5500	

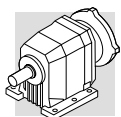





# C 35

# 450 Nm

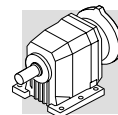
	i	$n_1 = 2800 \text{ min}^{-1}$					$n_1 = 1400 \text{ min}^{-1}$					
		$n_2$ $\text{min}^{-1}$	$M_{n2}$ Nm	$P_{n1}$ kW	$R_{n1}$ N	$R_{n2}$ N	$n_2$ $\text{min}^{-1}$	$M_{n2}$ Nm	$P_{n1}$ kW	$R_{n1}$ N	$R_{n2}$ N	
C 35 2_2.7	2.7	1037	140	16.0	670	1750	519	170	9.7	1150	2240	122
C 35 2_3.5	3.5	800	150	13.2	910	1920	400	185	8.2	1320	2440	
C 35 2_4.6	4.6	609	165	11.1	920	2110	304	200	6.7	1470	2700	
C 35 2_5.8	5.8	483	170	9.0	1160	2330	241	200	5.3	1990	3020	
C 35 2_6.1	6.1	459	275	13.9	1580	2040	230	345	8.7	2020	2570	
C 35 2_6.8	6.8	412	285	12.9	1750	2130	206	355	8.1	2220	2710	
C 35 2_7.9	7.9	354	305	11.9	1590	2200	177	380	7.4	2090	2790	
C 35 2_8.8	8.8	318	310	10.9	1780	2330	159	380	6.7	2270	3000	
C 35 2_10.5	10.5	267	335	9.8	1610	2410	133	380	5.6	2270	3250	
C 35 2_11.7	11.7	239	340	9.0	1790	2560	120	380	5.0	2370	3460	
C 35 2_13.3	13.3	211	355	8.2	1660	2650	105	380	4.4	2340	3660	
C 35 2_14.8	14.8	189	360	7.5	1800	2810	95	380	4.0	2440	3890	
C 35 2_17.1	17.1	164	380	6.9	1640	2910	82	380	3.4	2410	4150	
C 35 2_19.0	19.0	147	380	6.2	1820	3110	74	380	3.1	2500	4400	
C 35 3_20.2	20.2	139	315	4.9	2300	3500	69	395	3.1	2900	4420	
C 35 3_22.1	22.1	127	340	4.9	2300	3570	63	430	3.1	2900	4490	
C 35 3_26.2	26.2	107	355	4.3	2300	3760	53	450	2.7	2890	4730	
C 35 3_28.7	28.7	98	385	4.2	2300	3820	49	450	2.5	2930	4980	
C 35 3_34.7	34.7	81	395	3.6	2300	4110	40	450	2.0	2930	5410	
C 35 3_38.1	38.1	73	435	3.6	2300	4140	37	450	1.9	2970	5690	
C 35 3_43.9	43.9	64	430	3.1	2300	4430	32	450	1.6	2960	6030	
C 35 3_48.2	48.2	58	450	2.9	2310	4580	29.0	450	1.5	2990	6330	
C 35 3_56.5	56.5	50	450	2.5	2300	4910	24.8	450	1.3	2990	6500	
C 35 3_62.0	62.0	45	450	2.3	2330	5170	22.6	450	1.1	3000	6500	
C 35 3_70.7	70.7	40	450	2.0	2320	5460	19.8	450	1.0	3000	6500	
C 35 3_77.6	77.6	36	450	1.8	2350	5740	18.0	450	0.91	3000	6500	
C 35 3_83.8	83.8	33	450	1.7	2330	5910	16.7	450	0.85	3000	6500	
C 35 3_91.9	91.9	30	450	1.5	2360	6200	15.2	450	0.77	3000	6500	
C 35 3_101.6	101.6	27.6	450	1.4	2340	6450	13.8	450	0.70	3000	6500	
C 35 3_111.5	111.5	25.1	450	1.3	2360	6500	12.6	450	0.64	3000	6500	
C 35 3_127.3	127.3	22.0	450	1.1	2350	6500	11.0	450	0.56	3000	6500	
C 35 3_139.8	139.8	20.0	450	1.0	2370	6500	10.0	450	0.51	3000	6500	
C 35 3_147.6	147.6	19.0	450	0.96	2350	6500	9.5	450	0.48	3000	6500	
C 35 3_162.0	162.0	17.3	450	0.88	2380	6500	8.6	450	0.44	3000	6500	
C 35 3_188.0	188.0	14.9	450	0.75	2360	6500	7.4	450	0.38	3000	6500	
C 35 3_206.4	206.4	13.6	450	0.69	2380	6500	6.8	450	0.34	3000	6500	
C 35 4_232.3	232.3	12.1	450	0.62	1170	6500	6.0	450	0.31	1300	6500	
C 35 4_255.0	255.0	11.0	450	0.57	1190	6500	5.5	450	0.28	1300	6500	
C 35 4_290.6	290.6	9.6	450	0.50	1220	6500	4.8	450	0.25	1300	6500	
C 35 4_318.9	318.9	8.8	450	0.45	1230	6500	4.4	450	0.23	1300	6500	
C 35 4_344.3	344.3	8.1	450	0.42	1240	6500	4.1	450	0.21	1300	6500	
C 35 4_377.9	377.9	7.4	450	0.38	1260	6500	3.7	450	0.19	1300	6500	
C 35 4_417.6	417.6	6.7	450	0.35	1270	6500	3.4	450	0.17	1300	6500	
C 35 4_458.4	458.4	6.1	450	0.32	1280	6500	3.1	450	0.16	1300	6500	
C 35 4_523.5	523.5	5.3	450	0.28	1290	6500	2.7	450	0.14	1300	6500	
C 35 4_574.7	574.7	4.9	450	0.25	1300	6500	2.4	450	0.13	1300	6500	
C 35 4_606.6	606.6	4.6	450	0.24	1300	6500	2.3	450	0.12	1300	6500	
C 35 4_665.9	665.9	4.2	450	0.22	1300	6500	2.1	450	0.11	1300	6500	
C 35 4_773.0	773.0	3.6	450	0.19	1300	6500	1.8	450	0.09	1300	6500	
C 35 4_848.5	848.5	3.3	450	0.17	1300	6500	1.6	450	0.09	1300	6500	



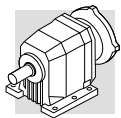

	i	$n_1 = 900 \text{ min}^{-1}$					$n_1 = 500 \text{ min}^{-1}$					
		$n_2$ $\text{min}^{-1}$	$M_{n2}$ Nm	$P_{n1}$ kW	$R_{n1}$ N	$R_{n2}$ N	$n_2$ $\text{min}^{-1}$	$M_{n2}$ Nm	$P_{n1}$ kW	$R_{n1}$ N	$R_{n2}$ N	
C 35 2_2.7	2.7	333	190	7.0	1670	2640	185	200	4.1	3000	3390	122
C 35 2_3.5	3.5	257	200	5.7	2160	2920	143	200	3.1	3000	3810	
C 35 2_4.6	4.6	196	200	4.3	2590	3320	109	200	2.4	3000	4300	
C 35 2_5.8	5.8	155	200	3.4	2680	3690	86	200	1.9	3000	4740	
C 35 2_6.1	6.1	148	380	6.2	2530	3080	82	380	3.4	3000	4150	
C 35 2_6.8	6.8	132	380	5.5	2660	3290	74	380	3.1	3000	4400	
C 35 2_7.9	7.9	114	380	4.8	2680	3530	63	380	2.7	3000	4690	
C 35 2_8.8	8.8	102	380	4.3	2790	3750	57	380	2.4	3000	4960	
C 35 2_10.5	10.5	86	380	3.6	2790	4060	48	380	2.0	3000	5340	
C 35 2_11.7	11.7	77	380	3.2	2900	4300	43	380	1.8	3000	5630	
C 35 2_13.3	13.3	68	380	2.8	2870	4540	38	380	1.6	3000	5930	
C 35 2_14.8	14.8	61	380	2.5	2970	4800	34	380	1.4	3000	6240	
C 35 2_17.1	17.1	53	380	2.2	2940	5110	29.2	380	1.2	3000	6500	
C 35 2_19.0	19.0	47	380	2.0	3000	5390	26.3	380	1.1	3000	6500	
C 35 3_20.2	20.2	45	450	2.3	3000	5160	24.8	450	1.3	3000	6500	
C 35 3_22.1	22.1	41	450	2.1	3000	5430	22.6	450	1.1	3000	6500	
C 35 3_26.2	26.2	34	450	1.7	3000	5830	19.1	450	0.97	3000	6500	
C 35 3_28.7	28.7	31	450	1.6	3000	6120	17.4	450	0.88	3000	6500	
C 35 3_34.7	34.7	25.9	450	1.3	3000	6500	14.4	450	0.73	3000	6500	
C 35 3_38.1	38.1	23.6	450	1.2	3000	6500	13.1	450	0.66	3000	6500	
C 35 3_43.9	43.9	20.5	450	1.0	3000	6500	11.4	450	0.58	3000	6500	
C 35 3_48.2	48.2	18.7	450	0.95	3000	6500	10.4	450	0.53	3000	6500	
C 35 3_56.5	56.5	15.9	450	0.81	3000	6500	8.8	450	0.45	3000	6500	
C 35 3_62.0	62.0	14.5	450	0.74	3000	6500	8.1	450	0.41	3000	6500	
C 35 3_70.7	70.7	12.7	450	0.64	3000	6500	7.1	450	0.36	3000	6500	
C 35 3_77.6	77.6	11.6	450	0.59	3000	6500	6.4	450	0.33	3000	6500	
C 35 3_83.8	83.8	10.7	450	0.54	3000	6500	6.0	450	0.30	3000	6500	
C 35 3_91.9	91.9	9.8	450	0.50	3000	6500	5.4	450	0.28	3000	6500	
C 35 3_101.6	101.6	8.9	450	0.45	3000	6500	4.9	450	0.25	3000	6500	
C 35 3_111.5	111.5	8.1	450	0.41	3000	6500	4.5	450	0.23	3000	6500	
C 35 3_127.3	127.3	7.1	450	0.36	3000	6500	3.9	450	0.20	3000	6500	
C 35 3_139.8	139.8	6.4	450	0.33	3000	6500	3.6	450	0.18	3000	6500	
C 35 3_147.6	147.6	6.1	450	0.31	3000	6500	3.4	450	0.17	3000	6500	
C 35 3_162.0	162.0	5.6	450	0.28	3000	6500	3.1	450	0.16	3000	6500	
C 35 3_188.0	188.0	4.8	450	0.24	3000	6500	2.7	450	0.13	3000	6500	
C 35 3_206.4	206.4	4.4	450	0.22	3000	6500	2.4	450	0.12	3000	6500	
C 35 4_232.3	232.3	3.9	450	0.20	1300	6500	2.2	450	0.11	1300	6500	
C 35 4_255.0	255.0	3.5	450	0.18	1300	6500	2.0	450	0.10	1300	6500	
C 35 4_290.6	290.6	3.1	450	0.16	1300	6500	1.7	450	0.09	1300	6500	
C 35 4_318.9	318.9	2.8	450	0.15	1300	6500	1.6	450	0.08	1300	6500	
C 35 4_344.3	344.3	2.6	450	0.14	1300	6500	1.5	450	0.08	1300	6500	
C 35 4_377.9	377.9	2.4	450	0.12	1300	6500	1.3	450	0.07	1300	6500	
C 35 4_417.6	417.6	2.2	450	0.11	1300	6500	1.2	450	0.06	1300	6500	
C 35 4_458.4	458.4	2.0	450	0.10	1300	6500	1.1	450	0.06	1300	6500	
C 35 4_523.5	523.5	1.7	450	0.09	1300	6500	1.0	450	0.05	1300	6500	
C 35 4_574.7	574.7	1.6	450	0.08	1300	6500	0.87	450	0.05	1300	6500	
C 35 4_606.6	606.6	1.5	450	0.08	1300	6500	0.82	450	0.04	1300	6500	
C 35 4_665.9	665.9	1.4	450	0.07	1300	6500	0.75	450	0.04	1300	6500	
C 35 4_773.0	773.0	1.2	450	0.06	1300	6500	0.65	450	0.03	1300	6500	
C 35 4_848.5	848.5	1.1	450	0.05	1300	6500	0.59	450	0.03	1300	6500	





# C 41

# 600 Nm

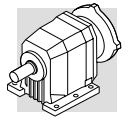
	i	n <sub>1</sub> = 2800 min <sup>-1</sup>					n <sub>1</sub> = 1400 min <sup>-1</sup>					
		n <sub>2</sub> min <sup>-1</sup>	M <sub>n2</sub> Nm	P <sub>n1</sub> kW	R <sub>n1</sub> N	R <sub>n2</sub> N	n <sub>2</sub> min <sup>-1</sup>	M <sub>n2</sub> Nm	P <sub>n1</sub> kW	R <sub>n1</sub> N	R <sub>n2</sub> N	
C 41 2_2.7	2.7	1037	245	28	980	1290	519	245	14.0	1390	2060	125
C 41 2_3.6	3.6	778	255	22	1070	1540	389	255	10.9	1650	2390	
C 41 2_4.7	4.7	596	260	17.1	1170	1800	298	260	8.5	2010	2730	
C 41 2_6.0	6.0	467	260	13.4	1290	2100	233	260	6.7	2400	3110	
C 41 2_6.4	6.4	438	275	13.3	2270	2590	219	345	8.3	2860	3260	
C 41 2_7.1	7.1	394	285	12.4	2360	2700	197	355	7.7	2980	3420	
C 41 2_8.6	8.6	326	305	10.9	2300	2860	163	385	6.9	2900	3600	
C 41 2_9.6	9.6	292	310	10.0	2410	3010	146	390	6.3	3030	3800	
C 41 2_11.2	11.2	250	335	9.2	2310	3100	125	420	5.8	2910	3920	
C 41 2_12.4	12.4	226	340	8.5	2440	3270	113	425	5.3	3070	4140	
C 41 2_14.2	14.2	197	355	7.7	2330	3410	99	445	4.8	2980	4300	
C 41 2_15.8	15.8	177	360	7.0	2460	3590	89	450	4.4	3120	4540	
C 41 2_17.8	17.8	157	380	6.6	2330	3680	79	480	4.2	3050	4630	
C 41 2_19.8	19.8	141	385	6.0	2460	3880	71	485	3.8	3180	4890	
C 41 2_22.6	22.6	124	410	5.6	2320	3990	62	500	3.4	3110	5110	
C 41 2_25.0	25.0	112	415	5.1	2460	4210	56	500	3.1	3230	5420	
C 41 2_28.3	28.3	99	445	4.9	2310	4290	49	500	2.7	3180	5710	
C 41 2_31.4	31.4	89	445	4.4	2440	4550	45	500	2.5	3300	6040	
C 41 2_33.4	33.4	84	465	4.3	2390	4560	42	500	2.3	3220	6170	
C 41 2_37.1	37.1	75	470	3.9	2440	4810	38	500	2.1	3320	6520	
C 41 2_44.8	44.8	63	500	3.4	2660	5130	31	500	1.7	3500	7000	
C 41 3_28.5	28.5	98	445	4.9	3060	4300	49	560	3.1	3500	5420	
C 41 3_31.2	31.2	90	450	4.5	3090	4510	45	570	2.9	3500	5670	
C 41 3_36.8	36.8	76	480	4.1	3070	4710	38	600	2.6	3500	5960	
C 41 3_40.3	40.3	69	485	3.8	3100	4940	35	600	2.3	3500	6280	
C 41 3_47.0	47.0	60	515	3.5	3070	5140	29.8	600	2.0	3500	6720	
C 41 3_51.5	51.5	54	525	3.2	3090	5360	27.2	600	1.8	3500	7000	
C 41 3_58.7	58.7	48	550	3.0	3070	5550	23.9	600	1.6	3500	7000	
C 41 3_64.3	64.3	44	560	2.7	3090	5800	21.8	600	1.5	3500	7000	
C 41 3_74.4	74.4	38	590	2.5	3060	6040	18.8	600	1.3	3500	7000	
C 41 3_81.5	81.5	34	600	2.3	3090	6310	17.2	600	1.2	3500	7000	
C 41 3_93.3	93.3	30	600	2.0	3080	6700	15.0	600	1.0	3500	7000	
C 41 3_102.3	102.3	27.4	600	1.8	3110	7000	13.7	600	0.92	3500	7000	
C 41 3_110.1	110.1	25.4	600	1.7	3090	7000	12.7	600	0.86	3500	7000	
C 41 3_120.6	120.6	23.2	600	1.6	3110	7000	11.6	600	0.78	3500	7000	
C 41 3_132.9	132.9	21.1	600	1.4	3090	7000	10.5	600	0.71	3500	7000	
C 41 3_145.6	145.6	19.2	600	1.3	3120	7000	9.6	600	0.65	3500	7000	
C 41 3_164.1	164.1	17.1	600	1.2	3100	7000	8.5	600	0.58	3500	7000	
C 41 3_179.9	179.9	15.6	600	1.1	3120	7000	7.8	600	0.53	3500	7000	
C 41 3_190.8	190.8	14.7	600	0.99	3110	7000	7.3	600	0.50	3500	7000	
C 41 3_209.1	209.1	13.4	600	0.90	3130	7000	6.7	600	0.45	3500	7000	
C 41 4_239.9	239.9	11.7	600	0.81	1480	7000	5.8	600	0.40	1910	7000	
C 41 4_263.0	263.0	10.6	600	0.74	1500	7000	5.3	600	0.37	1920	7000	
C 41 4_304.2	304.2	9.2	600	0.64	1520	7000	4.6	600	0.32	1950	7000	
C 41 4_333.4	333.4	8.4	600	0.58	1530	7000	4.2	600	0.29	1960	7000	
C 41 4_381.8	381.8	7.3	600	0.51	1540	7000	3.7	600	0.25	1970	7000	
C 41 4_418.5	418.5	6.7	600	0.46	1550	7000	3.3	600	0.23	1980	7000	
C 41 4_450.2	450.2	6.2	600	0.43	1560	7000	3.1	600	0.21	1990	7000	
C 41 4_493.5	493.5	5.7	600	0.39	1570	7000	2.8	600	0.20	2000	7000	
C 41 4_543.5	543.5	5.2	600	0.36	1570	7000	2.6	600	0.18	2000	7000	
C 41 4_595.8	595.8	4.7	600	0.32	1580	7000	2.3	600	0.16	2010	7000	
C 41 4_671.3	671.3	4.2	600	0.29	1590	7000	2.1	600	0.14	2020	7000	
C 41 4_735.9	735.9	3.8	600	0.26	1590	7000	1.9	600	0.13	2020	7000	
C 41 4_780.4	780.4	3.6	600	0.25	1600	7000	1.8	600	0.12	2030	7000	
C 41 4_855.5	855.5	3.3	600	0.23	1600	7000	1.6	600	0.11	2030	7000	



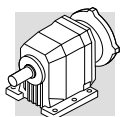

	i	$n_1 = 900 \text{ min}^{-1}$					$n_1 = 500 \text{ min}^{-1}$					
		$n_2$ $\text{min}^{-1}$	$M_{n2}$ Nm	$P_{n1}$ kW	$R_{n1}$ N	$R_{n2}$ N	$n_2$ $\text{min}^{-1}$	$M_{n2}$ Nm	$P_{n1}$ kW	$R_{n1}$ N	$R_{n2}$ N	
C 41 2_2.7	2.7	333	245	9.0	2560	2650	185	245	5.0	3500	3590	125
C 41 2_3.6	3.6	250	255	7.0	2710	3050	139	255	3.9	3500	4090	
C 41 2_4.7	4.7	191	260	5.5	2900	3440	106	260	3.0	3500	4570	
C 41 2_6.0	6.0	150	260	4.3	3080	3890	83	260	2.4	3500	5110	
C 41 2_6.4	6.4	141	400	6.2	3310	3780	78	490	4.2	3500	4580	
C 41 2_7.1	7.1	127	415	5.8	3460	3940	70	500	3.9	3500	4820	
C 41 2_8.6	8.6	105	445	5.1	3360	4180	58	500	3.2	3500	5290	
C 41 2_9.6	9.6	94	450	4.7	3500	4410	52	500	2.9	3500	5600	
C 41 2_11.2	11.2	80	490	4.3	3500	4520	45	500	2.5	3500	5980	
C 41 2_12.4	12.4	73	495	4.0	3500	4780	40	500	2.2	3500	6320	
C 41 2_14.2	14.2	63	500	3.5	3500	5060	35	500	1.9	3500	6700	
C 41 2_15.8	15.8	57	500	3.1	3500	5370	32	500	1.7	3500	7000	
C 41 2_17.8	17.8	51	500	2.8	3500	5650	28.1	500	1.5	3500	7000	
C 41 2_19.8	19.8	45	500	2.5	3500	5970	25.3	500	1.4	3500	7000	
C 41 2_22.6	22.6	40	500	2.2	3500	6320	22.1	500	1.2	3500	7000	
C 41 2_25.0	25.0	36	500	2.0	3500	6670	20.0	500	1.1	3500	7000	
C 41 2_28.3	28.3	32	500	1.8	3500	7000	17.7	500	0.97	3500	7000	
C 41 2_31.4	31.4	28.7	500	1.6	3500	7000	15.9	500	0.88	3500	7000	
C 41 2_33.4	33.4	26.9	500	1.5	3500	7000	15.0	500	0.83	3500	7000	
C 41 2_37.1	37.1	24.3	500	1.3	3500	7000	13.5	500	0.74	3500	7000	
C 41 2_44.8	44.8	20.1	500	1.1	3500	7000	11.2	500	0.62	3500	7000	
C 41 3_28.5	28.5	32	600	2.1	3500	6530	17.5	600	1.2	3500	7000	
C 41 3_31.2	31.2	28.8	600	1.9	3500	6870	16.0	600	1.1	3500	7000	
C 41 3_36.8	36.8	24.5	600	1.7	3500	7000	13.6	600	0.92	3500	7000	
C 41 3_40.3	40.3	22.3	600	1.5	3500	7000	12.4	600	0.84	3500	7000	
C 41 3_47.0	47.0	19.1	600	1.3	3500	7000	10.6	600	0.72	3500	7000	
C 41 3_51.5	51.5	17.5	600	1.2	3500	7000	9.7	600	0.66	3500	7000	
C 41 3_58.7	58.7	15.3	600	1.0	3500	7000	8.5	600	0.58	3500	7000	
C 41 3_64.3	64.3	14.0	600	0.95	3500	7000	7.8	600	0.53	3500	7000	
C 41 3_74.4	74.4	12.1	600	0.82	3500	7000	6.7	600	0.45	3500	7000	
C 41 3_81.5	81.5	11.0	600	0.75	3500	7000	6.1	600	0.41	3500	7000	
C 41 3_93.3	93.3	9.6	600	0.65	3500	7000	5.4	600	0.36	3500	7000	
C 41 3_102.3	102.3	8.8	600	0.59	3500	7000	4.9	600	0.33	3500	7000	
C 41 3_110.1	110.1	8.2	600	0.55	3500	7000	4.5	600	0.31	3500	7000	
C 41 3_120.6	120.6	7.5	600	0.50	3500	7000	4.1	600	0.28	3500	7000	
C 41 3_132.9	132.9	6.8	600	0.46	3500	7000	3.8	600	0.25	3500	7000	
C 41 3_145.6	145.6	6.2	600	0.42	3500	7000	3.4	600	0.23	3500	7000	
C 41 3_164.1	164.1	5.5	600	0.37	3500	7000	3.0	600	0.21	3500	7000	
C 41 3_179.9	179.9	5.0	600	0.34	3500	7000	2.8	600	0.19	3500	7000	
C 41 3_190.8	190.8	4.7	600	0.32	3500	7000	2.6	600	0.18	3500	7000	
C 41 3_209.1	209.1	4.3	600	0.29	3500	7000	2.4	600	0.16	3500	7000	
C 41 4_239.9	239.9	3.8	600	0.26	2200	7000	2.1	600	0.14	2200	7000	
C 41 4_263.0	263.0	3.4	600	0.24	2200	7000	1.9	600	0.13	2200	7000	
C 41 4_304.2	304.2	3.0	600	0.20	2200	7000	1.6	600	0.11	2200	7000	
C 41 4_333.4	333.4	2.7	600	0.19	2200	7000	1.5	600	0.10	2200	7000	
C 41 4_381.8	381.8	2.4	600	0.16	2200	7000	1.3	600	0.09	2200	7000	
C 41 4_418.5	418.5	2.2	600	0.15	2200	7000	1.2	600	0.08	2200	7000	
C 41 4_450.2	450.2	2.0	600	0.14	2200	7000	1.1	600	0.08	2200	7000	
C 41 4_493.5	493.5	1.8	600	0.13	2200	7000	1.0	600	0.07	2200	7000	
C 41 4_543.5	543.5	1.7	600	0.11	2200	7000	0.92	600	0.06	2200	7000	
C 41 4_595.8	595.8	1.5	600	0.10	2200	7000	0.84	600	0.06	2200	7000	
C 41 4_671.3	671.3	1.3	600	0.09	2200	7000	0.74	600	0.05	2200	7000	
C 41 4_735.9	735.9	1.2	600	0.08	2200	7000	0.68	600	0.05	2200	7000	
C 41 4_780.4	780.4	1.2	600	0.08	2200	7000	0.64	600	0.04	2200	7000	
C 41 4_855.5	855.5	1.1	600	0.07	2200	7000	0.58	600	0.04	2200	7000	





# C 51

# 1000 Nm

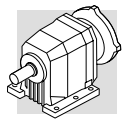
	i	n <sub>1</sub> = 2800 min <sup>-1</sup>					n <sub>1</sub> = 1400 min <sup>-1</sup>					
		n <sub>2</sub> min <sup>-1</sup>	M <sub>n2</sub> Nm	P <sub>n1</sub> kW	R <sub>n1</sub> N	R <sub>n2</sub> N	n <sub>2</sub> min <sup>-1</sup>	M <sub>n2</sub> Nm	P <sub>n1</sub> kW	R <sub>n1</sub> N	R <sub>n2</sub> N	
C 51 2_2.6	2.6	1077	315	37	980	3340	538	400	24	1390	4200	128
C 51 2_3.3	3.3	848	340	32	1070	3610	424	420	19.6	1650	4580	
C 51 2_4.5	4.5	622	370	25	1170	4010	311	435	14.9	2010	5180	
C 51 2_5.6	5.6	500	390	21	1290	4380	250	435	12.0	2400	5760	
C 51 2_7.0	7.0	400	500	22	2270	4760	200	630	13.9	2860	6000	
C 51 2_7.8	7.8	359	510	20	2360	4940	179	640	12.7	2980	6230	
C 51 2_8.8	8.8	318	545	19.1	2300	5120	159	685	12.0	2900	6450	
C 51 2_9.8	9.8	286	545	17.2	2410	5350	143	685	10.8	3030	6750	
C 51 2_11.8	11.8	237	610	16.0	2310	5620	119	770	10.1	2910	7080	
C 51 2_13.1	13.1	214	595	14.0	2440	5930	107	750	8.8	3070	7470	
C 51 2_15.0	15.0	187	660	13.6	2330	6080	93	800	8.2	2980	7770	
C 51 2_16.6	16.6	169	640	11.9	2460	6420	84	795	7.4	3120	8130	
C 51 2_18.9	18.9	148	695	11.3	2330	6630	74	800	6.5	3050	8620	
C 51 2_21.0	21.0	133	675	9.9	2460	7000	67	795	5.8	3180	9020	
C 51 2_23.4	23.4	120	735	9.7	2320	7160	60	800	5.3	3110	9460	
C 51 2_25.9	25.9	108	715	8.5	2460	7550	54	795	4.7	3230	9890	
C 51 2_29.8	29.8	94	795	8.2	2310	7770	47	800	4.1	3180	10000	
C 51 2_33.0	33.0	85	775	7.2	2440	8190	42	795	3.7	3300	10000	
C 51 2_36.4	36.4	77	750	6.4	2390	8660	38	790	3.3	3220	10000	
C 51 2_40.4	40.4	69	795	6.1	2440	8870	35	795	3.0	3320	10000	
C 51 2_43.1	43.1	65	730	5.2	2450	9380	32	770	2.8	3280	10000	
C 51 2_47.8	47.8	59	800	5.2	2460	9530	29.3	800	2.6	3350	10000	
C 51 2_51.4	51.4	54	665	4.0	2550	10000	27.2	700	2.1	3390	10000	
C 51 2_57.0	57.0	49	745	4.0	2540	10000	24.6	785	2.1	3380	10000	
C 51 3_21.8	21.8	128	720	10.4	2870	6940	64	905	6.5	3500	8750	
C 51 3_23.9	23.9	117	730	9.6	2910	7230	59	920	6.1	3500	9110	
C 51 3_27.4	27.4	102	770	8.9	2890	7510	51	970	5.6	3500	9470	
C 51 3_30.1	30.1	93	780	8.2	2930	7830	47	1000	5.2	3500	9810	
C 51 3_37.0	37.0	76	840	7.2	2910	8330	38	1000	4.3	3500	10000	
C 51 3_40.5	40.5	69	855	6.7	2940	8670	35	1000	3.9	3500	10000	
C 51 3_46.7	46.7	60	905	6.1	2920	9020	30	1000	3.4	3500	10000	
C 51 3_51.2	51.2	55	920	5.7	2950	9390	27.3	1000	3.1	3500	10000	
C 51 3_59.0	59.0	47	970	5.2	2910	9780	23.7	1000	2.7	3500	10000	
C 51 3_64.6	64.6	43	1000	4.9	2940	10000	21.7	1000	2.4	3500	10000	
C 51 3_72.9	72.9	38	1000	4.3	2920	10000	19.2	1000	2.2	3500	10000	
C 51 3_79.9	79.9	35	1000	3.9	2960	10000	17.5	1000	2.0	3500	10000	
C 51 3_93.0	93.0	30	1000	3.4	2950	10000	15.1	1000	1.7	3500	10000	
C 51 3_101.8	101.8	27.5	1000	3.1	2990	10000	13.8	1000	1.5	3500	10000	
C 51 3_113.6	113.6	24.6	1000	2.8	2960	10000	12.3	1000	1.4	3500	10000	
C 51 3_124.4	124.4	22.5	1000	2.5	3000	10000	11.3	1000	1.3	3500	10000	
C 51 3_134.6	134.6	20.8	1000	2.3	2970	10000	10.4	1000	1.2	3500	10000	
C 51 3_147.4	147.4	19.0	1000	2.1	3010	10000	9.5	1000	1.1	3500	10000	
C 51 3_160.5	160.5	17.4	1000	2.0	2980	10000	8.7	1000	0.98	3500	10000	
C 51 3_175.8	175.8	15.9	1000	1.8	3020	10000	8.0	1000	0.90	3500	10000	
C 51 3_197.9	197.9	14.1	1000	1.6	2980	10000	7.1	1000	0.80	3500	10000	
C 51 3_216.7	216.7	12.9	1000	1.5	3020	10000	6.5	1000	0.73	3500	10000	
C 51 4_240.9	240.9	11.6	1000	1.3	2100	10000	5.8	1000	0.67	2200	10000	
C 51 4_263.8	263.8	10.6	1000	1.2	2120	10000	5.3	1000	0.61	2200	10000	
C 51 4_297.8	297.8	9.4	1000	1.1	2140	10000	4.7	1000	0.54	2200	10000	
C 51 4_326.1	326.1	8.6	1000	0.99	2160	10000	4.3	1000	0.49	2200	10000	
C 51 4_379.6	379.6	7.4	1000	0.85	2190	10000	3.7	1000	0.42	2200	10000	
C 51 4_415.7	415.7	6.7	1000	0.78	2200	10000	3.4	1000	0.39	2200	10000	
C 51 4_463.9	463.9	6.0	1000	0.69	2200	10000	3.0	1000	0.35	2200	10000	
C 51 4_508.0	508.0	5.5	1000	0.63	2200	10000	2.8	1000	0.32	2200	10000	
C 51 4_549.7	549.7	5.1	1000	0.59	2200	10000	2.5	1000	0.29	2200	10000	
C 51 4_602.0	602.0	4.7	1000	0.54	2200	10000	2.3	1000	0.27	2200	10000	
C 51 4_655.4	655.4	4.3	1000	0.49	2200	10000	2.1	1000	0.25	2200	10000	
C 51 4_717.7	717.7	3.9	1000	0.45	2200	10000	2.0	1000	0.22	2200	10000	
C 51 4_808.0	808.0	3.5	1000	0.40	2200	10000	1.7	1000	0.20	2200	10000	
C 51 4_884.9	884.9	3.2	1000	0.36	2200	10000	1.6	1000	0.18	2200	10000	



	i	$n_1 = 900 \text{ min}^{-1}$					$n_1 = 500 \text{ min}^{-1}$					
		$n_2$ $\text{min}^{-1}$	$M_{n2}$ Nm	$P_{n1}$ kW	$R_{n1}$ N	$R_{n2}$ N	$n_2$ $\text{min}^{-1}$	$M_{n2}$ Nm	$P_{n1}$ kW	$R_{n1}$ N	$R_{n2}$ N	
C 51 2_2.6	2.6	346	400	15.3	2560	5130	192	400	8.5	3500	6620	128
C 51 2_3.3	3.3	273	420	12.6	2710	5590	152	420	7.0	3500	7200	
C 51 2_4.5	4.5	200	435	9.6	2900	6300	111	435	5.3	3500	8070	
C 51 2_5.6	5.6	161	435	7.7	3080	6970	89	435	4.3	3500	8880	
C 51 2_7.0	7.0	129	730	10.3	3310	6950	71	800	6.3	3500	8760	
C 51 2_7.8	7.8	115	740	9.4	3460	7220	64	800	5.7	3500	9140	
C 51 2_8.8	8.8	102	795	9.0	3360	7470	57	800	5.0	3500	9680	
C 51 2_9.8	9.8	92	800	8.1	3500	7790	51	800	4.5	3500	10000	
C 51 2_11.8	11.8	76	800	6.7	3500	8530	42	800	3.7	3500	10000	
C 51 2_13.1	13.1	69	800	6.1	3500	8900	38	800	3.4	3500	10000	
C 51 2_15.0	15.0	60	800	5.3	3500	9450	33	800	2.9	3500	10000	
C 51 2_16.6	16.6	54	800	4.8	3500	9850	30	800	2.7	3500	10000	
C 51 2_18.9	18.9	48	800	4.2	3500	10000	26.5	800	2.3	3500	10000	
C 51 2_21.0	21.0	43	800	3.8	3500	10000	23.8	800	2.1	3500	10000	
C 51 2_23.4	23.4	38	800	3.4	3500	10000	21.4	800	1.9	3500	10000	
C 51 2_25.9	25.9	35	800	3.1	3500	10000	19.3	800	1.7	3500	10000	
C 51 2_29.8	29.8	30	800	2.7	3500	10000	16.8	800	1.5	3500	10000	
C 51 2_33.0	33.0	27.3	800	2.4	3500	10000	15.2	800	1.3	3500	10000	
C 51 2_36.4	36.4	24.7	800	2.2	3500	10000	13.7	800	1.2	3500	10000	
C 51 2_40.4	40.4	22.3	800	2.0	3500	10000	12.4	800	1.1	3500	10000	
C 51 2_43.1	43.1	20.9	800	1.8	3500	10000	11.6	800	1.0	3500	10000	
C 51 2_47.8	47.8	18.8	800	1.7	3500	10000	10.5	800	0.92	3500	10000	
C 51 2_51.4	51.4	17.5	725	1.4	3500	10000	9.7	755	0.81	3500	10000	
C 51 2_57.0	57.0	15.8	795	1.4	3500	10000	8.8	795	0.77	3500	10000	
C 51 3_21.8	21.8	41	1000	4.6	3500	10000	22.9	1000	2.6	3500	10000	
C 51 3_23.9	23.9	38	1000	4.2	3500	10000	20.9	1000	2.4	3500	10000	
C 51 3_27.4	27.4	33	1000	3.7	3500	10000	18.2	1000	2.1	3500	10000	
C 51 3_30.1	30.1	29.9	1000	3.4	3500	10000	16.6	1000	1.9	3500	10000	
C 51 3_37.0	37.0	24.3	1000	2.7	3500	10000	13.5	1000	1.5	3500	10000	
C 51 3_40.5	40.5	22.2	1000	2.5	3500	10000	12.3	1000	1.4	3500	10000	
C 51 3_46.7	46.7	19.3	1000	2.2	3500	10000	10.7	1000	1.2	3500	10000	
C 51 3_51.2	51.2	17.6	1000	2.0	3500	10000	9.8	1000	1.1	3500	10000	
C 51 3_59.0	59.0	15.3	1000	1.7	3500	10000	8.5	1000	0.95	3500	10000	
C 51 3_64.6	64.6	13.9	1000	1.6	3500	10000	7.7	1000	0.87	3500	10000	
C 51 3_72.9	72.9	12.3	1000	1.4	3500	10000	6.9	1000	0.77	3500	10000	
C 51 3_79.9	79.9	11.3	1000	1.3	3500	10000	6.3	1000	0.70	3500	10000	
C 51 3_93.0	93.0	9.7	1000	1.1	3500	10000	5.4	1000	0.61	3500	10000	
C 51 3_101.8	101.8	8.8	1000	1.0	3500	10000	4.9	1000	0.55	3500	10000	
C 51 3_113.6	113.6	7.9	1000	0.89	3500	10000	4.4	1000	0.50	3500	10000	
C 51 3_124.4	124.4	7.2	1000	0.81	3500	10000	4.0	1000	0.45	3500	10000	
C 51 3_134.6	134.6	6.7	1000	0.75	3500	10000	3.7	1000	0.42	3500	10000	
C 51 3_147.4	147.4	6.1	1000	0.69	3500	10000	3.4	1000	0.38	3500	10000	
C 51 3_160.5	160.5	5.6	1000	0.63	3500	10000	3.1	1000	0.35	3500	10000	
C 51 3_175.8	175.8	5.1	1000	0.58	3500	10000	2.8	1000	0.32	3500	10000	
C 51 3_197.9	197.9	4.5	1000	0.51	3500	10000	2.5	1000	0.28	3500	10000	
C 51 3_216.7	216.7	4.2	1000	0.47	3500	10000	2.3	1000	0.26	3500	10000	
C 51 4_240.9	240.9	3.7	1000	0.43	2200	10000	2.1	1000	0.24	2200	10000	
C 51 4_263.8	263.8	3.4	1000	0.39	2200	10000	1.9	1000	0.22	2200	10000	
C 51 4_297.8	297.8	3.0	1000	0.35	2200	10000	1.7	1000	0.19	2200	10000	
C 51 4_326.1	326.1	2.8	1000	0.32	2200	10000	1.5	1000	0.18	2200	10000	
C 51 4_379.6	379.6	2.4	1000	0.27	2200	10000	1.3	1000	0.15	2200	10000	
C 51 4_415.7	415.7	2.2	1000	0.25	2200	10000	1.2	1000	0.14	2200	10000	
C 51 4_463.9	463.9	1.9	1000	0.22	2200	10000	1.1	1000	0.12	2200	10000	
C 51 4_508.0	508.0	1.8	1000	0.20	2200	10000	1.0	1000	0.11	2200	10000	
C 51 4_549.7	549.7	1.6	1000	0.19	2200	10000	0.91	1000	0.10	2200	10000	
C 51 4_602.0	602.0	1.5	1000	0.17	2200	10000	0.83	1000	0.10	2200	10000	
C 51 4_655.4	655.4	1.4	1000	0.16	2200	10000	0.76	1000	0.09	2200	10000	
C 51 4_717.7	717.7	1.3	1000	0.14	2200	10000	0.70	1000	0.08	2200	10000	
C 51 4_808.0	808.0	1.1	1000	0.13	2200	10000	0.62	1000	0.07	2200	10000	
C 51 4_884.9	884.9	1.0	1000	0.12	2200	10000	0.57	1000	0.07	2200	10000	

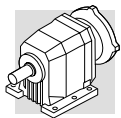



# C 61

# 1600 Nm

	i	n <sub>1</sub> = 2800 min <sup>-1</sup>					n <sub>1</sub> = 1400 min <sup>-1</sup>					
		n <sub>2</sub> min <sup>-1</sup>	M <sub>n2</sub> Nm	P <sub>n1</sub> kW	R <sub>n1</sub> N	R <sub>n2</sub> N	n <sub>2</sub> min <sup>-1</sup>	M <sub>n2</sub> Nm	P <sub>n1</sub> kW	R <sub>n1</sub> N	R <sub>n2</sub> N	
C 61 2_2.8	2.8	1000	445	49	—	4670	500	550	30	770	5930	131
C 61 2_3.7	3.7	757	530	44	—	4950	378	575	24	1730	6600	
C 61 2_4.6	4.6	609	575	39	—	5280	304	600	20	2150	7130	
C 61 2_6.0	6.0	467	575	30	—	6000	233	625	16.1	2700	7950	
C 61 2_6.7	6.7	418	900	41	2230	5600	209	1130	26	2850	7060	
C 61 2_7.5	7.5	373	1000	41	2220	5620	187	1250	26	2900	7110	
C 61 2_8.8	8.8	318	1000	35	2290	6080	159	1250	22	2980	7690	
C 61 2_9.8	9.8	286	1100	35	2380	6140	143	1350	21	3330	7850	
C 61 2_10.9	10.9	257	1050	30	2530	6590	128	1350	19.1	2940	8210	
C 61 2_12.1	12.1	231	1150	29	2670	6670	116	1350	17.2	3600	8730	
C 61 2_14.3	14.3	196	1150	25	2450	7220	98	1350	14.6	3590	9430	
C 61 2_15.9	15.9	176	1250	24	2660	7350	88	1350	13.1	3780	9990	
C 61 2_17.7	17.7	158	1200	21	2540	7850	79	1350	11.8	3700	10400	
C 61 2_19.6	19.6	143	1300	20	2780	8000	71	1350	10.6	3890	11000	
C 61 2_22.4	22.4	125	1250	17.2	2630	8650	63	1350	9.3	3810	11600	
C 61 2_24.8	24.8	113	1350	16.8	2840	8840	56	1350	8.4	3980	12300	
C 61 2_27.4	27.4	102	1300	14.6	2600	9390	51	1350	7.6	3880	12800	
C 61 2_30.4	30.4	92	1350	13.7	2900	9770	46	1350	6.9	4050	13500	
C 61 2_34.2	34.2	82	1165	10.5	3020	10900	41	1225	5.5	4090	14500	
C 61 2_38.0	38.0	74	1280	10.4	3030	11100	37	1350	5.5	4100	14800	
C 61 3_26.8	26.8	104	1140	13.4	3740	9810	52	1435	8.4	4700	12400	
C 61 3_29.4	29.4	95	1160	12.4	3780	10200	48	1465	7.9	4700	12900	
C 61 3_33.0	33.0	85	1210	11.6	3750	10600	42	1525	7.3	4700	13300	
C 61 3_36.1	36.1	78	1235	10.8	3800	11000	39	1555	6.8	4700	13800	
C 61 3_43.4	43.4	65	1315	9.6	3760	11600	32	1600	5.8	4700	14800	
C 61 3_47.6	47.6	59	1340	8.9	3810	12100	29.4	1600	5.3	4700	15500	
C 61 3_53.5	53.5	52	1400	8.2	3760	12500	26.2	1600	4.7	4700	16000	
C 61 3_58.6	58.6	48	1430	7.7	3810	13000	23.9	1600	4.3	4700	16000	
C 61 3_67.7	67.7	41	1505	7.0	3750	13500	20.7	1600	3.7	4700	16000	
C 61 3_74.2	74.2	38	1535	6.5	3800	14100	18.9	1600	3.4	4700	16000	
C 61 3_83.0	83.0	34	1600	6.1	3740	14500	16.9	1600	3.0	4700	16000	
C 61 3_91.0	91.0	31	1600	5.5	3800	15200	15.4	1600	2.8	4700	16000	
C 61 3_103.6	103.6	27.0	1600	4.9	3760	16000	13.5	1600	2.4	4700	16000	
C 61 3_113.6	113.6	24.6	1600	4.4	3820	16000	12.3	1600	2.2	4700	16000	
C 61 3_128.1	128.1	21.9	1600	3.9	3790	16000	10.9	1600	2.0	4700	16000	
C 61 3_140.5	140.5	19.9	1600	3.6	3840	16000	10.0	1600	1.8	4700	16000	
C 61 3_150	150.0	18.7	1600	3.4	3800	16000	9.3	1600	1.7	4700	16000	
C 61 3_164.5	164.5	17.0	1600	3.1	3850	16000	8.5	1600	1.5	4700	16000	
C 61 3_178.6	178.6	15.7	1600	2.8	3800	16000	7.8	1600	1.4	4700	16000	
C 61 3_195.8	195.8	14.3	1600	2.6	3860	16000	7.2	1600	1.3	4700	16000	
C 61 4_217.4	217.4	12.9	1600	2.4	3020	16000	6.4	1600	1.2	3500	16000	
C 61 4_238.3	238.3	11.7	1600	2.2	3060	16000	5.9	1600	1.1	3500	16000	
C 61 4_275.3	275.3	10.2	1600	1.9	3100	16000	5.1	1600	0.94	3500	16000	
C 61 4_301.7	301.7	9.3	1600	1.7	3130	16000	4.6	1600	0.85	3500	16000	
C 61 4_337.7	337.7	8.3	1600	1.5	3160	16000	4.1	1600	0.76	3500	16000	
C 61 4_370.1	370.1	7.6	1600	1.4	3180	16000	3.8	1600	0.70	3500	16000	
C 61 4_421.5	421.5	6.6	1600	1.2	3200	16000	3.3	1600	0.61	3500	16000	
C 61 4_462.0	462.0	6.1	1600	1.1	3220	16000	3.0	1600	0.56	3500	16000	
C 61 4_521.1	521.1	5.4	1600	0.99	3240	16000	2.7	1600	0.49	3500	16000	
C 61 4_571.2	571.2	4.9	1600	0.90	3250	16000	2.5	1600	0.45	3500	16000	
C 61 4_610.1	610.1	4.6	1600	0.84	3260	16000	2.3	1600	0.42	3500	16000	
C 61 4_668.8	668.8	4.2	1600	0.77	3280	16000	2.1	1600	0.39	3500	16000	
C 61 4_726.3	726.3	3.9	1600	0.71	3290	16000	1.9	1600	0.35	3500	16000	
C 61 4_796.1	796.1	3.5	1600	0.65	3300	16000	1.8	1600	0.32	3500	16000	

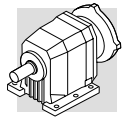
(-) Interpellare il ns. servizio tecnico comunicando i dati relativi al carico radiale (senso di rotazione, orientamento, posizione)  
 (-) Contact our technical service department advising radial load data (rotation direction, orientation, position)  
 (-) Nehmen Sie bitte Kontakt mit unserem Applikationsdienst und Querkraftsdaten angeben (Drehrichtung, Orientierung, Anordnung)  
 (-) Consulter notre service technique en donnant les détails concernant la charge radiale (sens de rotation, indexage, position)





	i	n <sub>1</sub> = 900 min <sup>-1</sup>					n <sub>1</sub> = 500 min <sup>-1</sup>					
		n <sub>2</sub> min <sup>-1</sup>	M <sub>n2</sub> Nm	P <sub>n1</sub> kW	R <sub>n1</sub> N	R <sub>n2</sub> N	n <sub>2</sub> min <sup>-1</sup>	M <sub>n2</sub> Nm	P <sub>n1</sub> kW	R <sub>n1</sub> N	R <sub>n2</sub> N	
C 61 2_2.8	2.8	321	565	20	2840	7150	179	665	13.1	4050	8790	131
C 61 2_3.7	3.7	243	625	16.8	3000	7800	135	665	9.9	4700	9860	
C 61 2_4.6	4.6	196	665	14.3	3170	8380	109	665	8.0	4700	10760	
C 61 2_6.0	6.0	150	665	11.0	4120	9440	83	665	6.1	4700	12000	
C 61 2_6.7	6.7	134	1350	20	2850	8050	75	1350	11.1	4700	10800	
C 61 2_7.5	7.5	120	1350	17.9	4010	8560	67	1350	9.9	4700	11400	
C 61 2_8.8	8.8	102	1350	15.2	4070	9240	57	1350	8.5	4700	12200	
C 61 2_9.8	9.8	92	1350	13.7	4310	9790	51	1350	7.6	4700	12900	
C 61 2_10.9	10.9	83	1350	12.3	4270	10200	46	1350	6.8	4700	13400	
C 61 2_12.1	12.1	74	1350	11.1	4480	10800	41	1350	6.1	4700	14100	
C 61 2_14.3	14.3	63	1350	9.4	4470	11600	35	1350	5.2	4700	15100	
C 61 2_15.9	15.9	57	1350	8.4	4660	12300	31	1350	4.7	4700	15900	
C 61 2_17.7	17.7	51	1350	7.6	4580	12800	28.2	1350	4.2	4700	16000	
C 61 2_19.6	19.6	46	1350	6.8	4700	13500	25.5	1350	3.8	4700	16000	
C 61 2_22.4	22.4	40	1350	6.0	4690	14200	22.3	1350	3.3	4700	16000	
C 61 2_24.8	24.8	36	1350	5.4	4700	14900	20.2	1350	3.0	4700	16000	
C 61 2_27.4	27.4	33	1350	4.9	4700	15500	18.2	1350	2.7	4700	16000	
C 61 2_30.4	30.4	29.6	1350	4.4	4700	16000	16.4	1350	2.4	4700	16000	
C 61 2_34.2	34.2	26.3	1265	3.7	4700	16000	14.6	1325	2.1	4700	16000	
C 61 2_38.0	38.0	23.7	1350	3.5	4700	16000	13.2	1350	2.0	4700	16000	
C 61 3_26.8	26.8	34	1600	6.0	4700	14500	18.7	1600	3.4	4700	16000	
C 61 3_29.4	29.4	31	1600	5.5	4700	15200	17.0	1600	3.1	4700	16000	
C 61 3_33.0	33.0	27.3	1600	4.9	4700	15900	15.2	1600	2.7	4700	16000	
C 61 3_36.1	36.1	24.9	1600	4.5	4700	16000	13.9	1600	2.5	4700	16000	
C 61 3_43.4	43.4	20.7	1600	3.7	4700	16000	11.5	1600	2.1	4700	16000	
C 61 3_47.6	47.6	18.9	1600	3.4	4700	16000	10.5	1600	1.9	4700	16000	
C 61 3_53.5	53.5	16.8	1600	3.0	4700	16000	9.3	1600	1.7	4700	16000	
C 61 3_58.6	58.6	15.4	1600	2.8	4700	16000	8.5	1600	1.5	4700	16000	
C 61 3_67.7	67.7	13.3	1600	2.4	4700	16000	7.4	1600	1.3	4700	16000	
C 61 3_74.2	74.2	12.1	1600	2.2	4700	16000	6.7	1600	1.2	4700	16000	
C 61 3_83.0	83.0	10.8	1600	2.0	4700	16000	6.0	1600	1.1	4700	16000	
C 61 3_91.0	91.0	9.9	1600	1.8	4700	16000	5.5	1600	0.99	4700	16000	
C 61 3_103.6	103.6	8.7	1600	1.6	4700	16000	4.8	1600	0.87	4700	16000	
C 61 3_113.6	113.6	7.9	1600	1.4	4700	16000	4.4	1600	0.79	4700	16000	
C 61 3_128.1	128.1	7.0	1600	1.3	4700	16000	3.9	1600	0.70	4700	16000	
C 61 3_140.5	140.5	6.4	1600	1.2	4700	16000	3.6	1600	0.64	4700	16000	
C 61 3_150	150.0	6.0	1600	1.1	4700	16000	3.3	1600	0.60	4700	16000	
C 61 3_164.5	164.5	5.5	1600	0.99	4700	16000	3.0	1600	0.55	4700	16000	
C 61 3_178.6	178.6	5.0	1600	0.91	4700	16000	2.8	1600	0.50	4700	16000	
C 61 3_195.8	195.8	4.6	1600	0.83	4700	16000	2.6	1600	0.46	4700	16000	
C 61 4_217.4	217.4	4.1	1600	0.76	3500	16000	2.3	1600	0.42	3500	16000	
C 61 4_238.3	238.3	3.8	1600	0.70	3500	16000	2.1	1600	0.39	3500	16000	
C 61 4_275.3	275.3	3.3	1600	0.60	3500	16000	1.8	1600	0.33	3500	16000	
C 61 4_301.7	301.7	3.0	1600	0.55	3500	16000	1.7	1600	0.31	3500	16000	
C 61 4_337.7	337.7	2.7	1600	0.49	3500	16000	1.5	1600	0.27	3500	16000	
C 61 4_370.1	370.1	2.4	1600	0.45	3500	16000	1.4	1600	0.25	3500	16000	
C 61 4_421.5	421.5	2.1	1600	0.39	3500	16000	1.2	1600	0.22	3500	16000	
C 61 4_462.0	462.0	1.9	1600	0.36	3500	16000	1.1	1600	0.20	3500	16000	
C 61 4_521.1	521.1	1.7	1600	0.32	3500	16000	1.0	1600	0.18	3500	16000	
C 61 4_571.2	571.2	1.6	1600	0.29	3500	16000	0.88	1600	0.16	3500	16000	
C 61 4_610.1	610.1	1.5	1600	0.27	3500	16000	0.82	1600	0.15	3500	16000	
C 61 4_668.8	668.8	1.3	1600	0.25	3500	16000	0.75	1600	0.14	3500	16000	
C 61 4_726.3	726.3	1.2	1600	0.23	3500	16000	0.69	1600	0.13	3500	16000	
C 61 4_796.1	796.1	1.1	1600	0.21	3500	16000	0.63	1600	0.12	3500	16000	

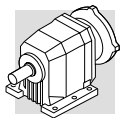





# C 70

# 2300 Nm

	i	$n_1 = 2800 \text{ min}^{-1}$					$n_1 = 1400 \text{ min}^{-1}$					
		$n_2$ $\text{min}^{-1}$	$M_{n2}$ Nm	$P_{n1}$ kW	$R_{n1}$ N	$R_{n2}$ N	$n_2$ $\text{min}^{-1}$	$M_{n2}$ Nm	$P_{n1}$ kW	$R_{n1}$ N	$R_{n2}$ N	
<b>C 70 2_4.6</b>	4.6	613	1400	95	—	5590	306	1700	57	—	7100	134
<b>C 70 2_5.9</b>	5.9	479	1550	82	—	5610	239	1900	50	—	6990	
<b>C 70 2_6.3</b>	6.3	448	1600	79	1980	6570	224	1950	48	2630	8250	
<b>C 70 2_7.5</b>	7.5	375	1550	64	—	7130	188	1950	40	—	8400	
<b>C 70 2_8.0</b>	8.0	350	1750	68	1760	6840	175	2100	41	2670	8880	
<b>C 70 2_9.5</b>	9.5	294	1600	52	770	8260	147	2000	32	620	9910	
<b>C 70 2_10.2</b>	10.2	274	1900	57	2000	7200	137	2100	32	4470	10800	
<b>C 70 2_11.2</b>	11.2	250	1600	44	1130	9350	125	2000	28	1070	11300	
<b>C 70 2_13.0</b>	13.0	215	2050	49	1860	7700	107	2100	25	5600	12900	
<b>C 70 2_14.1</b>	14.1	199	1700	37	1100	10120	99	2100	23	1280	12400	
<b>C 70 2_15.3</b>	15.3	183	2100	42	1810	8540	91	2100	21	5860	14300	
<b>C 70 2_16.7</b>	16.7	168	1700	31	1570	11400	84	2050	18.9	2350	14300	
<b>C 70 2_19.3</b>	19.3	145	2100	34	2730	10370	73	2100	16.8	6000	16300	
<b>C 70 2_22.9</b>	22.9	123	2100	28	3160	11760	61	2100	14.2	6060	18000	
<b>C 70 2_27.7</b>	27.7	101	2100	23	3570	13390	51	2100	11.7	6120	19900	
<b>C 70 2_34.7</b>	34.7	81	2100	18.7	3960	15390	40	2100	9.3	6180	22200	
<b>C 70 3_41.3</b>	41.3	68	1900	14.5	5670	18400	34	2300	8.8	7000	22800	
<b>C 70 3_44.7</b>	44.7	63	1900	13.4	5700	19100	31	2300	8.1	7000	23800	
<b>C 70 3_52.2</b>	52.2	54	2050	12.4	5680	19600	26.8	2300	7.0	7000	25000	
<b>C 70 3_56.5</b>	56.5	50	2050	11.4	5710	20400	24.8	2300	6.4	7000	25000	
<b>C 70 3_65.9</b>	65.9	43	2200	10.5	5670	21000	21.3	2300	5.5	7000	25000	
<b>C 70 3_71.3</b>	71.3	39	2200	9.7	5710	21900	19.6	2300	5.1	7000	25000	
<b>C 70 3_81.4</b>	81.4	34	2300	8.9	5680	22700	17.2	2300	4.5	7000	25000	
<b>C 70 3_88.2</b>	88.2	32	2300	8.2	5710	23600	15.9	2300	4.1	7000	25000	
<b>C 70 3_103.8</b>	103.8	27.0	2300	7.0	5700	25000	13.5	2300	3.5	7000	25000	
<b>C 70 3_112.4</b>	112.4	24.9	2300	6.4	5740	25000	12.5	2300	3.2	7000	25000	
<b>C 70 3_126.8</b>	126.8	22.1	2300	5.7	5720	25000	11.0	2300	2.9	7000	25000	
<b>C 70 3_137.4</b>	137.4	20.4	2300	5.3	5750	25000	10.2	2300	2.6	7000	25000	
<b>C 70 3_150.3</b>	150.3	18.6	2300	4.8	5730	25000	9.3	2300	2.4	7000	25000	
<b>C 70 3_162.8</b>	162.8	17.2	2300	4.5	5760	25000	8.6	2300	2.2	7000	25000	
<b>C 70 3_179.2</b>	179.2	15.6	2300	4.0	5740	25000	7.8	2300	2.0	7000	25000	
<b>C 70 3_194.1</b>	194.1	14.4	2300	3.7	5770	25000	7.2	2300	1.9	7000	25000	
<b>C 70 3_220.9</b>	220.9	12.7	2250	3.2	5750	25000	6.3	2250	1.6	7000	25000	
<b>C 70 3_239.3</b>	239.3	11.7	2300	3.0	5770	25000	5.8	2300	1.5	7000	25000	
<b>C 70 4_251.3</b>	251.3	11.1	2300	2.9	2000	25000	5.6	2300	1.5	2620	25000	
<b>C 70 4_272.2</b>	272.2	10.3	2300	2.7	2030	25000	5.1	2300	1.4	2650	25000	
<b>C 70 4_317.9</b>	317.9	8.8	2300	2.3	2030	25000	4.4	2300	1.2	2650	25000	
<b>C 70 4_344.3</b>	344.3	8.1	2300	2.2	2050	25000	4.1	2300	1.1	2670	25000	
<b>C 70 4_409.4</b>	409.4	6.8	2300	1.8	2050	25000	3.4	2300	0.90	2670	25000	
<b>C 70 4_443.5</b>	443.5	6.3	2300	1.7	2070	25000	3.2	2300	0.80	2700	25000	
<b>C 70 4_512.0</b>	512.0	5.5	2300	1.4	2070	25000	2.7	2300	0.70	2680	25000	
<b>C 70 4_554.7</b>	554.7	5.0	2300	1.3	2090	25000	2.5	2300	0.70	2710	25000	
<b>C 70 4_606.8</b>	606.8	4.6	2300	1.2	2080	25000	2.3	2300	0.60	2700	25000	
<b>C 70 4_657.3</b>	657.3	4.3	2300	1.1	2100	25000	2.1	2300	0.60	2720	25000	
<b>C 70 4_736.0</b>	736.0	3.8	2300	1.0	2090	25000	1.9	2300	0.50	2700	25000	
<b>C 70 4_797.3</b>	797.3	3.5	2300	0.90	2110	25000	1.8	2300	0.50	2720	25000	
<b>C 70 4_922.6</b>	922.6	3.0	2300	0.80	2100	25000	1.5	2300	0.40	2710	25000	
<b>C 70 4_999.5</b>	999.5	2.8	2300	0.70	2110	25000	1.4	2300	0.40	2730	25000	
<b>C 70 4_1069</b>	1069	2.6	2300	0.70	2100	25000	1.3	2300	0.30	2720	25000	
<b>C 70 4_1158</b>	1158	2.4	2300	0.60	2100	25000	1.2	2300	0.30	2800	25000	
<b>C 70 4_1362</b>	1362	2.1	2300	0.50	2100	25000	1.0	2300	0.30	2800	25000	
<b>C 70 4_1476</b>	1476	1.9	2300	0.50	2100	25000	0.90	2300	0.30	2800	25000	

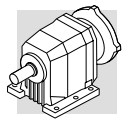
(-) Interpellare il ns. servizio tecnico comunicando i dati relativi al carico radiale (senso di rotazione, orientamento, posizione)  
 (-) Contact our technical service department advising radial load data (rotation direction, load angle, offset)  
 (-) Nehmen Sie bitte Kontakt mit unserem Applikationsdienst und Querkraftsdaten angeben (Drehrichtung, Orientierung, Anordnung)  
 (-) Consulter notre service technique en donnant les détails concernant la charge radiale (sens de rotation, indexage, position)



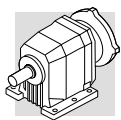

	i	n <sub>1</sub> = 900 min <sup>-1</sup>					n <sub>1</sub> = 500 min <sup>-1</sup>					
		n <sub>2</sub> min <sup>-1</sup>	M <sub>n2</sub> Nm	P <sub>n1</sub> kW	R <sub>n1</sub> N	R <sub>n2</sub> N	n <sub>2</sub> min <sup>-1</sup>	M <sub>n2</sub> Nm	P <sub>n1</sub> kW	R <sub>n1</sub> N	R <sub>n2</sub> N	
C 70 2_4.6	4.6	197	1800	39	650	9360	109	1800	22	5500	13900	134
C 70 2_5.9	5.9	154	1950	33	560	9980	85	2150	20.0	2890	13400	
C 70 2_6.3	6.3	144	2100	33	4260	10400	80	2100	18.5	7000	15500	
C 70 2_7.5	7.5	121	2100	28	1120	10800	67	2150	15.9	5400	15600	
C 70 2_8.0	8.0	113	2100	26	5800	12500	63	2100	14.5	7000	17800	
C 70 2_9.5	9.5	95	2150	22	2140	12400	53	2150	12.4	6990	18100	
C 70 2_10.2	10.2	88	2100	20.0	6870	14600	49	2100	11.3	7000	20200	
C 70 2_11.2	11.2	80	2150	19.0	2620	14000	45	2150	10.6	7000	19800	
C 70 2_13.0	13.0	69	2100	16.0	7000	16900	38	2100	8.9	7000	22800	
C 70 2_14.1	14.1	64	2150	15.1	3900	16000	35	2150	8.4	7000	22300	
C 70 2_15.3	15.3	59	2100	13.6	7000	18400	33	2100	7.5	7000	24600	
C 70 2_16.7	16.7	54	2050	12.2	5470	18500	29.9	2050	6.8	7000	25000	
C 70 2_19.3	19.3	47	2100	10.8	7000	20700	25.9	2100	6.0	7000	25000	
C 70 2_22.9	22.9	39	2100	9.1	7000	22500	21.9	2100	5.1	7000	25000	
C 70 2_27.7	27.7	32	2100	7.5	7000	24600	18.0	2100	4.2	7000	25000	
C 70 2_34.7	34.7	25.9	2100	6.0	7000	25000	14.4	2100	3.3	7000	25000	
C 70 3_41.3	41.3	21.8	2300	5.6	7000	25000	12.1	2300	3.1	7000	25000	
C 70 3_44.7	44.7	20.1	2300	5.2	7000	25000	11.2	2300	2.9	7000	25000	
C 70 3_52.2	52.2	17.3	2300	4.5	7000	25000	9.6	2300	2.5	7000	25000	
C 70 3_56.5	56.5	15.9	2300	4.1	7000	25000	8.8	2300	2.3	7000	25000	
C 70 3_65.9	65.9	13.7	2300	3.5	7000	25000	7.6	2300	2.0	7000	25000	
C 70 3_71.3	71.3	12.6	2300	3.3	7000	25000	7.0	2300	1.8	7000	25000	
C 70 3_81.4	81.4	11.1	2300	2.9	7000	25000	6.1	2300	1.6	7000	25000	
C 70 3_88.2	88.2	10.2	2300	2.6	7000	25000	5.7	2300	1.5	7000	25000	
C 70 3_103.8	103.8	8.7	2300	2.2	7000	25000	4.8	2300	1.2	7000	25000	
C 70 3_112.4	112.4	8.0	2300	2.1	7000	25000	4.4	2300	1.2	7000	25000	
C 70 3_126.8	126.8	7.1	2300	1.8	7000	25000	3.9	2300	1.0	7000	25000	
C 70 3_137.4	137.4	6.6	2300	1.7	7000	25000	3.6	2300	0.90	7000	25000	
C 70 3_150.3	150.3	6.0	2300	1.6	7000	25000	3.3	2300	0.90	7000	25000	
C 70 3_162.8	162.8	5.5	2300	1.4	7000	25000	3.1	2300	0.80	7000	25000	
C 70 3_179.2	179.2	5.0	2300	1.3	7000	25000	2.8	2300	0.70	7000	25000	
C 70 3_194.1	194.1	4.6	2300	1.2	7000	25000	2.6	2300	0.70	7000	25000	
C 70 3_220.9	220.9	4.1	2250	1.0	7000	25000	2.3	2250	0.60	7000	25000	
C 70 3_239.3	239.3	3.8	2300	1.0	7000	25000	2.1	2300	0.50	7000	25000	
C 70 4_251.3	251.3	3.6	2300	0.90	2000	25000	2.0	2300	0.50	2620	25000	
C 70 4_272.2	272.2	3.3	2300	0.90	2030	25000	1.8	2300	0.50	2650	25000	
C 70 4_317.9	317.9	2.8	2300	0.70	2030	25000	1.6	2300	0.40	2650	25000	
C 70 4_344.3	344.3	2.6	2300	0.70	2050	25000	1.5	2300	0.40	2670	25000	
C 70 4_409.4	409.4	2.2	2300	0.60	2050	25000	1.2	2300	0.30	2670	25000	
C 70 4_443.5	443.5	2.0	2300	0.50	2070	25000	1.1	2300	0.30	2700	25000	
C 70 4_512.0	512.0	1.8	2300	0.50	2070	25000	1.0	2300	0.30	2680	25000	
C 70 4_554.7	554.7	1.6	2300	0.40	2090	25000	0.90	2300	0.20	2710	25000	
C 70 4_606.8	606.8	1.5	2300	0.40	2080	25000	0.80	2300	0.20	2700	25000	
C 70 4_657.3	657.3	1.4	2300	0.40	2100	25000	0.80	2300	0.20	2720	25000	
C 70 4_736.0	736.0	1.2	2300	0.30	2090	25000	0.70	2300	0.20	2700	25000	
C 70 4_797.3	797.3	1.1	2300	0.30	2110	25000	0.60	2300	0.20	2720	25000	
C 70 4_922.6	922.6	1.0	2300	0.30	2100	25000	0.50	2300	0.10	2710	25000	
C 70 4_999.5	999.5	0.90	2300	0.20	2110	25000	0.50	2300	0.10	2730	25000	
C 70 4_1069	1069	0.80	2300	0.20	2100	25000	0.50	2300	0.10	2720	25000	
C 70 4_1158	1158	0.80	2300	0.20	2100	25000	0.40	2300	0.10	2800	25000	
C 70 4_1362	1362	0.70	2300	0.20	2100	25000	0.40	2300	0.10	2800	25000	
C 70 4_1476	1476	0.60	2300	0.20	2100	25000	0.30	2300	0.10	2800	25000	





# C 80

# 4000 Nm

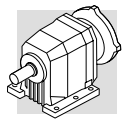
	i	n <sub>1</sub> = 2800 min <sup>-1</sup>					n <sub>1</sub> = 1400 min <sup>-1</sup>					
		n <sub>2</sub> min <sup>-1</sup>	M <sub>n2</sub> Nm	P <sub>n1</sub> kW	R <sub>n1</sub> N	R <sub>n2</sub> N	n <sub>2</sub> min <sup>-1</sup>	M <sub>n2</sub> Nm	P <sub>n1</sub> kW	R <sub>n1</sub> N	R <sub>n2</sub> N	
C 80 2_5.6	5.6	496	2400	131	370	10900	248	3100	85	690	12300	137
C 80 2_6.1	6.1	458	2450	124	890	11000	229	3150	80	1380	12700	
C 80 2_7.0	7.0	398	2650	116	350	11000	199	3350	73	910	12900	
C 80 2_7.6	7.6	367	2700	109	890	11300	183	3400	69	1600	13300	
C 80 2_8.9	8.9	316	2800	98	420	12100	158	3500	61	1120	14500	
C 80 2_9.6	9.6	292	3000	96	520	11300	146	3700	59	1380	13900	
C 80 2_11.1	11.1	252	2800	78	1110	14200	126	3500	49	1950	17100	
C 80 2_12.0	12.0	233	3000	77	1200	13500	116	3700	48	2190	16600	
C 80 2_13.8	13.8	203	2800	63	1420	16400	102	3500	39	2330	19800	
C 80 2_14.9	14.9	188	3000	62	1510	15800	94	3700	38	2560	19300	
C 80 2_16.7	16.7	168	2800	52	1840	18500	84	3500	32	2840	22300	
C 80 2_18.1	18.1	155	3000	50	1930	17900	78	3700	32	3060	22000	
C 80 2_20.5	20.5	136	2850	43	2000	20500	68	3550	27	3060	24800	
C 80 2_22.2	22.2	126	3000	42	2210	20300	63	3700	26	3400	24900	
C 80 2_24.0	24.0	117	2850	37	2090	22400	58	3550	23	3180	27000	
C 80 2_25.9	25.9	108	3000	36	2300	22300	54	3700	22	3510	27200	
C 80 2_31.3	31.3	89	3000	30	2480	24700	45	3700	18.2	3730	30000	
C 80 2_39.1	39.1	72	2500	19.7	3820	31000	36	3200	12.6	5060	35000	
C 80 3_43.5	43.5	64	3100	22.5	5610	28700	32	3800	13.8	7000	34800	
C 80 3_47.4	47.4	59	3100	20.6	5660	30000	29.5	3800	12.6	7000	35000	
C 80 3_57.3	57.3	49	3400	18.7	5620	30500	24.4	4000	11.0	7000	35000	
C 80 3_62.5	62.5	45	3400	17.1	5670	31800	22.4	4000	10.1	7000	35000	
C 80 3_70.5	70.5	40	3650	16.3	5620	32200	19.9	4000	8.9	7000	35000	
C 80 3_76.9	76.9	36	3600	14.8	5670	33900	18.2	4000	8.2	7000	35000	
C 80 3_89.3	89.3	31	3900	13.8	5620	34700	15.7	4000	7.1	7000	35000	
C 80 3_97.4	97.4	28.7	3900	12.6	5670	35000	14.4	4000	6.5	7000	35000	
C 80 3_109.5	109.5	25.5	4000	11.5	5630	35000	12.8	4000	5.8	7000	35000	
C 80 3_119.5	119.5	23.4	4000	10.6	5680	35000	11.7	4000	5.3	7000	35000	
C 80 3_136.7	136.7	20.5	4000	9.2	5660	35000	10.2	4000	4.6	7000	35000	
C 80 3_149.1	149.1	18.8	4000	8.5	5700	35000	9.4	4000	4.2	7000	35000	
C 80 3_169.0	169.0	16.6	4000	7.5	5680	35000	8.3	4000	3.7	7000	35000	
C 80 3_184.4	184.4	15.2	4000	6.8	5720	35000	7.6	4000	3.4	7000	35000	
C 80 3_197.9	197.9	14.2	3800	6.1	5710	35000	7.1	3800	3.0	7000	35000	
C 80 3_215.9	215.9	13.0	4000	5.8	5730	35000	6.5	4000	2.9	7000	35000	
C 80 4_261.9	261.9	10.7	4000	4.9	1850	35000	5.3	4000	2.5	2470	35000	
C 80 4_285.7	285.7	9.8	4000	4.5	1890	35000	4.9	4000	2.3	2510	35000	
C 80 4_334.3	334.3	8.4	4000	3.9	1880	35000	4.2	4000	1.9	2500	35000	
C 80 4_364.7	364.7	7.7	4000	3.5	1920	35000	3.8	4000	1.8	2540	35000	
C 80 4_417.5	417.5	6.7	4000	3.1	1910	35000	3.4	4000	1.5	2530	35000	
C 80 4_455.4	455.4	6.1	4000	2.8	1950	35000	3.1	4000	1.4	2570	35000	
C 80 4_529.3	529.3	5.3	4000	2.4	1940	35000	2.6	4000	1.2	2550	35000	
C 80 4_577.4	577.4	4.8	4000	2.2	1970	35000	2.4	4000	1.1	2590	35000	
C 80 4_664.3	664.3	4.2	4000	1.9	1960	35000	2.1	4000	1.0	2570	35000	
C 80 4_724.7	724.7	3.9	4000	1.8	1990	35000	1.9	4000	0.90	2610	35000	
C 80 4_783.4	783.4	3.6	4000	1.6	1970	35000	1.8	4000	0.80	2590	35000	
C 80 4_854.6	854.6	3.3	4000	1.5	2000	35000	1.6	4000	0.80	2620	35000	
C 80 4_945.7	945.7	3.0	4000	1.4	1980	35000	1.5	4000	0.70	2600	35000	
C 80 4_1032	1032	2.7	4000	1.2	2010	35000	1.4	4000	0.60	2630	35000	
C 80 4_1168	1168	2.4	4000	1.1	1980	35000	1.2	4000	0.60	2600	35000	
C 80 4_1274	1274	2.2	4000	1.0	2020	35000	1.1	4000	0.50	2640	35000	
C 80 4_1358	1358	2.1	4000	0.90	1990	35000	1.0	4000	0.50	2610	35000	
C 80 4_1481	1481	1.9	4000	0.90	2030	35000	0.90	4000	0.40	2640	35000	



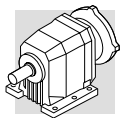

	i	$n_1 = 900 \text{ min}^{-1}$					$n_1 = 500 \text{ min}^{-1}$					
		$n_2$ $\text{min}^{-1}$	$M_{n2}$ Nm	$P_{n1}$ kW	$R_{n1}$ N	$R_{n2}$ N	$n_2$ $\text{min}^{-1}$	$M_{n2}$ Nm	$P_{n1}$ kW	$R_{n1}$ N	$R_{n2}$ N	
<b>C 80 2_5.6</b>	5.6	160	3500	62	1480	14400	89	3500	34	4970	21600	137
<b>C 80 2_6.1</b>	6.1	147	3600	58	2100	14400	82	3700	33	5270	21200	
<b>C 80 2_7.0</b>	7.0	128	3500	49	2630	17000	71	3500	27	6130	24600	
<b>C 80 2_7.6</b>	7.6	118	3650	47	3060	16800	66	3650	26	6550	24600	
<b>C 80 2_8.9</b>	8.9	102	3500	39	3330	19900	56	3500	22	6800	27800	
<b>C 80 2_9.6</b>	9.6	94	3700	38	3590	19400	52	3700	21	7000	27700	
<b>C 80 2_11.1</b>	11.1	81	3500	31	4160	22800	45	3500	17.4	7000	31200	
<b>C 80 2_12.0</b>	12.0	75	3700	31	4400	22500	42	3700	17.0	7000	31200	
<b>C 80 2_13.8</b>	13.8	65	3500	25	4540	25700	36	3500	14.0	7000	34700	
<b>C 80 2_14.9</b>	14.9	60	3700	25	4770	25500	34	3700	13.7	7000	34700	
<b>C 80 2_16.7</b>	16.7	54	3500	21	5050	28500	30	3500	11.6	7000	35000	
<b>C 80 2_18.1</b>	18.1	50	3700	20	5280	28400	27.7	3700	11.3	7000	35000	
<b>C 80 2_20.5</b>	20.5	44	3550	17.2	5270	31400	24.4	3550	9.5	7000	35000	
<b>C 80 2_22.2</b>	22.2	40	3700	16.5	5610	31600	22.5	3700	9.2	7000	35000	
<b>C 80 2_24.0</b>	24.0	38	3550	14.7	5390	33800	20.9	3550	8.2	7000	35000	
<b>C 80 2_25.9</b>	25.9	35	3700	14.1	5730	34200	19.3	3700	7.9	7000	35000	
<b>C 80 2_31.3</b>	31.3	28.7	3700	11.7	5940	35000	16.0	3700	6.5	7000	35000	
<b>C 80 2_39.1</b>	39.1	23.0	3200	8.1	7000	35000	12.8	3200	4.5	7000	35000	
<b>C 80 3_43.5</b>	43.5	20.7	4000	9.3	7000	35000	11.5	4000	5.2	7000	35000	
<b>C 80 3_47.4</b>	47.4	19.0	4000	8.5	7000	35000	10.5	4000	4.7	7000	35000	
<b>C 80 3_57.3</b>	57.3	15.7	4000	7.1	7000	35000	8.7	4000	3.9	7000	35000	
<b>C 80 3_62.5</b>	62.5	14.4	4000	6.5	7000	35000	8.0	4000	3.6	7000	35000	
<b>C 80 3_70.5</b>	70.5	12.8	4000	5.7	7000	35000	7.1	4000	3.2	7000	35000	
<b>C 80 3_76.9</b>	76.9	11.7	4000	5.3	7000	35000	6.5	4000	2.9	7000	35000	
<b>C 80 3_89.3</b>	89.3	10.1	4000	4.5	7000	35000	5.6	4000	2.5	7000	35000	
<b>C 80 3_97.4</b>	97.4	9.2	4000	4.2	7000	35000	5.1	4000	2.3	7000	35000	
<b>C 80 3_109.5</b>	109.5	8.2	4000	3.7	7000	35000	4.6	4000	2.1	7000	35000	
<b>C 80 3_119.5</b>	119.5	7.5	4000	3.4	7000	35000	4.2	4000	1.9	7000	35000	
<b>C 80 3_136.7</b>	136.7	6.6	4000	3.0	7000	35000	3.7	4000	1.6	7000	35000	
<b>C 80 3_149.1</b>	149.1	6.0	4000	2.7	7000	35000	3.4	4000	1.5	7000	35000	
<b>C 80 3_169.0</b>	169.0	5.3	4000	2.4	7000	35000	3.0	4000	1.3	7000	35000	
<b>C 80 3_184.4</b>	184.4	4.9	4000	2.2	7000	35000	2.7	4000	1.2	7000	35000	
<b>C 80 3_197.9</b>	197.9	4.5	3800	1.9	7000	35000	2.5	3800	1.1	7000	35000	
<b>C 80 3_215.9</b>	215.9	4.2	4000	1.9	7000	35000	2.3	4000	1.0	7000	35000	
<b>C 80 4_261.9</b>	261.9	3.4	4000	1.6	2950	35000	1.9	4000	0.90	3500	35000	
<b>C 80 4_285.7</b>	285.7	3.2	4000	1.4	2990	35000	1.8	4000	0.80	3500	35000	
<b>C 80 4_334.3</b>	334.3	2.7	4000	1.2	2980	35000	1.5	4000	0.70	3500	35000	
<b>C 80 4_364.7</b>	364.7	2.5	4000	1.1	3020	35000	1.4	4000	0.60	3500	35000	
<b>C 80 4_417.5</b>	417.5	2.2	4000	1.0	3000	35000	1.2	4000	0.60	3500	35000	
<b>C 80 4_455.4</b>	455.4	2.0	4000	0.90	3050	35000	1.1	4000	0.50	3500	35000	
<b>C 80 4_529.3</b>	529.3	1.7	4000	0.80	3030	35000	0.90	4000	0.40	3500	35000	
<b>C 80 4_577.4</b>	577.4	1.6	4000	0.70	3070	35000	0.90	4000	0.40	3500	35000	
<b>C 80 4_664.3</b>	664.3	1.4	4000	0.60	3050	35000	0.80	4000	0.30	3500	35000	
<b>C 80 4_724.7</b>	724.7	1.2	4000	0.60	3090	35000	0.70	4000	0.30	3500	35000	
<b>C 80 4_783.4</b>	783.4	1.1	4000	0.50	3060	35000	0.60	4000	0.30	3500	35000	
<b>C 80 4_854.6</b>	854.6	1.1	4000	0.50	3100	35000	0.60	4000	0.30	3500	35000	
<b>C 80 4_945.7</b>	945.7	1.0	4000	0.40	3070	35000	0.50	4000	0.20	3500	35000	
<b>C 80 4_1032</b>	1032	0.90	4000	0.40	3110	35000	0.50	4000	0.20	3500	35000	
<b>C 80 4_1168</b>	1168	0.80	4000	0.40	3080	35000	0.40	4000	0.20	3500	35000	
<b>C 80 4_1274</b>	1274	0.70	4000	0.30	3110	35000	0.40	4000	0.20	3500	35000	
<b>C 80 4_1358</b>	1358	0.70	4000	0.30	3090	35000	0.40	4000	0.20	3500	35000	
<b>C 80 4_1481</b>	1481	0.60	4000	0.30	3120	35000	0.30	4000	0.20	3500	35000	





# C 90

# 7200 Nm

	i	n <sub>1</sub> = 2800 min <sup>-1</sup>					n <sub>1</sub> = 1400 min <sup>-1</sup>					
		n <sub>2</sub> min <sup>-1</sup>	M <sub>n2</sub> Nm	P <sub>n1</sub> kW	R <sub>n1</sub> N	R <sub>n2</sub> N	n <sub>2</sub> min <sup>-1</sup>	M <sub>n2</sub> Nm	P <sub>n1</sub> kW	R <sub>n1</sub> N	R <sub>n2</sub> N	
C 90 2_5.2	5.2	542	3500	209	1700	12800	271	4300	128	2170	15800	140
C 90 2_5.6	5.6	500	3600	198	3240	12800	250	4400	121	4250	16000	
C 90 2_6.8	6.8	414	3850	176	1860	13390	207	4750	108	2210	16400	
C 90 2_7.3	7.3	383	3950	167	3470	13460	191	4850	102	4360	16700	
C 90 2_8.3	8.3	336	4150	154	2010	13830	168	5100	94	2540	17100	
C 90 2_9.0	9.0	310	4250	145	3660	13960	155	5200	89	4720	17500	
C 90 2_10.4	10.4	270	4500	134	990	14210	135	5550	83	1150	17400	
C 90 2_11.2	11.2	249	4600	126	2750	14390	125	5650	78	3460	17800	
C 90 2_12.8	12.8	219	4850	117	580	14670	109	5950	72	840	18200	
C 90 2_13.9	13.9	202	4900	109	2700	15330	101	6050	67	3220	18700	
C 90 2_16.0	16.0	175	5050	98	690	16790	88	6200	60	950	20800	
C 90 2_17.3	17.3	162	5300	94	1670	15880	81	6500	58	2200	19800	
C 90 2_18.7	18.7	150	5050	83	1140	19600	75	6200	51	1500	24300	
C 90 2_20.2	20.2	138	5400	82	1540	17920	69	6600	50	2160	22500	
C 90 2_22.9	22.9	122	5050	68	2110	22350	61	6200	42	2700	27600	
C 90 2_24.8	24.8	113	5400	67	2500	21890	56	6600	41	3340	27300	
C 90 2_27.2	27.2	103	4500	51	6160	26030	52	5500	31	7820	32200	
C 90 2_29.4	29.4	95	4800	50	6560	25960	48	5900	31	8130	32000	
C 90 2_35.1	35.1	80	4400	39	8090	29420	40	5400	24	11100	36300	
C 90 3_39.4	39.4	71	6350	51	10800	23900	36	7100	28	13700	32900	
C 90 3_43.0	43.0	65	6500	48	10800	24700	33	7200	26	13800	34000	
C 90 3_50.3	50.3	56	6800	43	10800	26000	27.8	7100	22	13800	37000	
C 90 3_54.9	54.9	51	7000	40	10900	26500	25.5	7200	21	13900	38300	
C 90 3_59.2	59.2	47	7100	38	10800	27700	23.6	7100	18.9	13900	40000	
C 90 3_64.6	64.6	43	7200	35	10900	29100	21.7	7200	17.6	14000	41300	
C 90 3_74.4	74.4	38	7100	30	10900	31900	18.8	7100	15.0	14000	44400	
C 90 3_81.2	81.2	34	7200	28	10900	33000	17.2	7200	14.0	14100	45900	
C 90 3_88.2	88.2	32	7100	25	11000	34800	15.9	7100	12.7	14000	47900	
C 90 3_96.2	96.2	29.1	7200	24	11000	35900	14.5	7200	11.8	14100	49400	
C 90 3_107.0	107.0	26.2	7100	21	11000	38100	13.1	7100	10.5	14100	52100	
C 90 3_116.7	116.7	24.0	7200	19.4	11000	39400	12.0	7200	9.7	14100	53700	
C 90 3_134.1	134.1	20.9	7100	16.7	11000	42400	10.4	7100	8.3	14100	57300	
C 90 3_146.3	146.3	19.1	7200	15.5	11000	43800	9.6	7200	7.8	14200	59000	
C 90 3_157.8	157.8	17.7	7100	14.2	11000	45600	8.9	7100	7.1	14100	60000	
C 90 3_172.1	172.1	16.3	7200	13.2	11000	47100	8.1	7200	6.6	14200	60000	
C 90 4_212.4	212.4	13.2	7200	10.9	—	60000	6.6	7200	5.5	1180	60000	
C 90 4_231.7	231.7	12.1	7200	10.0	—	60000	6.0	7200	5.0	1560	60000	
C 90 4_268.5	268.5	10.4	7200	8.6	—	60000	5.2	7200	4.3	1540	60000	
C 90 4_292.9	292.9	9.6	7200	7.9	—	60000	4.8	7200	4.0	1880	60000	
C 90 4_339.0	339.0	8.3	7200	6.8	—	60000	4.1	7200	3.4	1720	60000	
C 90 4_369.8	369.8	7.6	7200	6.3	—	60000	3.8	7200	3.1	2050	60000	
C 90 4_419.0	419.0	6.7	7200	5.5	—	60000	3.3	7200	2.8	1890	60000	
C 90 4_457.1	457.1	6.1	7200	5.1	—	60000	3.1	7200	2.5	2210	60000	
C 90 4_534.2	534.2	5.2	7200	4.3	—	60000	2.6	7200	2.2	2090	60000	
C 90 4_582.8	582.8	4.8	7200	4.0	—	60000	2.4	7200	2.0	2270	60000	
C 90 4_652.8	652.8	4.3	7200	3.6	—	60000	2.1	7200	1.8	2160	60000	
C 90 4_712.2	712.2	3.9	7200	3.3	—	60000	2.0	7200	1.6	2290	60000	
C 90 4_773.6	773.6	3.3	7200	3.0	—	60000	1.8	7200	1.5	2250	60000	
C 90 4_844.0	844.0	3.0	7200	2.7	—	60000	1.7	7200	1.4	2310	60000	
C 90 4_922.3	922.3	2.8	7200	2.5	—	60000	1.5	7200	1.3	2260	60000	
C 90 4_1006	1006	2.5	7200	2.3	—	60000	1.4	7200	1.2	2320	60000	
C 90 4_1137	1137	2.3	7200	2.0	—	60000	1.2	7200	1.0	2270	60000	
C 90 4_1240	1240	2.2	7200	1.9	—	60000	1.1	7200	0.90	2230	60000	

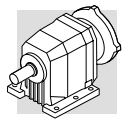
(-) Interpellare il ns. servizio tecnico comunicando i dati relativi al carico radiale (senso di rotazione, orientamento, posizione)  
 (-) Contact our technical service department advising radial load data (rotation direction, load angle, offset)  
 (-) Nehmen Sie bitte Kontakt mit unserem Applikationsdienst und Querkraftsdaten angeben (Drehrichtung, Orientierung, Anordnung)  
 (-) Consulter notre service technique en donnant les détails concernant la charge radiale (sens de rotation, indexage, position)



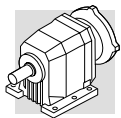

	i	n <sub>1</sub> = 900 min <sup>-1</sup>					n <sub>1</sub> = 500 min <sup>-1</sup>					
		n <sub>2</sub> min <sup>-1</sup>	M <sub>n2</sub> Nm	P <sub>n1</sub> kW	R <sub>n1</sub> N	R <sub>n2</sub> N	n <sub>2</sub> min <sup>-1</sup>	M <sub>n2</sub> Nm	P <sub>n1</sub> kW	R <sub>n1</sub> N	R <sub>n2</sub> N	
C 90 2_5.2	5.2	174	4900	94	2560	18200	97	5850	62	3010	21600	140
C 90 2_5.6	5.6	161	5050	89	4640	18100	89	6000	59	5720	21800	
C 90 2_6.8	6.8	133	5450	80	2310	18500	74	6200	51	5130	24600	
C 90 2_7.3	7.3	123	5550	75	4890	18900	68	6550	49	6340	23200	
C 90 2_8.3	8.3	108	5850	70	2700	19300	60	6200	41	8870	27800	
C 90 2_9.0	9.0	100	5950	65	5300	19800	55	6600	40	9660	27600	
C 90 2_10.4	10.4	87	6200	59	2250	21000	48	6200	33	11000	31000	
C 90 2_11.2	11.2	80	6450	57	3960	20400	45	6600	32	11700	30800	
C 90 2_12.8	12.8	70	6250	48	4500	25300	39	6250	27	13200	34100	
C 90 2_13.9	13.9	65	6550	47	5830	24400	36	6550	26	14600	34300	
C 90 2_16.0	16.0	56	6200	38	6570	28700	31	6200	21	15000	38000	
C 90 2_17.3	17.3	52	6550	38	7530	28600	28.9	6550	21	15000	38100	
C 90 2_18.7	18.7	48	6200	33	7120	31000	26.7	6200	18.3	15000	40700	
C 90 2_20.2	20.2	44	6600	32	7780	30800	24.8	6600	18.0	15000	40700	
C 90 2_22.9	22.9	39	6200	27	8310	34200	21.8	6200	14.9	15000	44500	
C 90 2_24.8	24.8	36	6600	26	8950	34100	20.2	6600	14.6	15000	44600	
C 90 2_27.2	27.2	33	5500	20	13400	39200	18.4	5500	11.2	15000	50000	
C 90 2_29.4	29.4	31	5900	19.9	13700	39100	17.0	5900	11.0	15000	50200	
C 90 2_35.1	35.1	25.6	5400	15.3	14100	43800	14.2	5400	8.5	15000	55500	
C 90 3_39.4	39.4	22.8	7100	18.3	15000	40600	12.7	7100	10.1	15000	40600	
C 90 3_43.0	43.0	20.9	7200	17.0	15000	42000	11.6	7200	9.4	15000	42000	
C 90 3_50.3	50.3	17.9	7100	14.3	15000	45400	9.9	7100	7.9	15000	45400	
C 90 3_54.9	54.9	16.4	7200	13.3	15000	46900	9.1	7200	7.4	15000	46900	
C 90 3_59.2	59.2	15.2	7100	12.2	15000	48800	8.4	7100	6.8	15000	48800	
C 90 3_64.6	64.6	13.9	7200	11.3	15000	50400	7.7	7200	6.3	15000	50400	
C 90 3_74.4	74.4	12.1	7100	9.7	15000	53800	6.7	7100	5.4	15000	53800	
C 90 3_81.2	81.2	11.1	7200	9.0	15000	55500	6.2	7200	5.0	15000	55500	
C 90 3_88.2	88.2	10.2	7100	8.2	15000	57800	5.7	7100	4.5	15000	57800	
C 90 3_96.2	96.2	9.4	7200	7.6	15000	59600	5.2	7200	4.2	15000	59600	
C 90 3_107.0	107.0	8.4	7100	6.7	15000	60000	4.7	7100	3.7	15000	60000	
C 90 3_116.7	116.7	7.7	7200	6.3	15000	60000	4.3	7200	3.5	15000	60000	
C 90 3_134.1	134.1	6.7	7100	5.4	15000	60000	3.7	7100	3.0	15000	60000	
C 90 3_146.3	146.3	6.2	7200	5.0	15000	60000	3.4	7200	2.8	15000	60000	
C 90 3_157.8	157.8	5.7	7100	4.6	15000	60000	3.2	7100	2.5	15000	60000	
C 90 3_172.1	172.1	5.2	7200	4.2	15000	60000	2.9	7200	2.4	15000	60000	
C 90 4_212.4	212.4	4.2	7200	3.5	2090	60000	2.4	7200	2.0	3210	60000	
C 90 4_231.7	231.7	3.9	7200	3.2	2460	60000	2.2	7200	1.8	3290	60000	
C 90 4_268.5	268.5	3.4	7200	2.8	2440	60000	1.9	7200	1.5	3300	60000	
C 90 4_292.9	292.9	3.1	7200	2.5	2620	60000	1.7	7200	1.4	3370	60000	
C 90 4_339.0	339.0	2.7	7200	2.2	2590	60000	1.5	7200	1.2	3340	60000	
C 90 4_369.8	369.8	2.4	7200	2.0	2660	60000	1.4	7200	1.1	3420	60000	
C 90 4_419.0	419.0	2.1	7200	1.8	2630	60000	1.2	7200	1.0	3390	60000	
C 90 4_457.1	457.1	2.0	7200	1.6	2700	60000	1.1	7200	0.90	3460	60000	
C 90 4_534.2	534.2	1.7	7200	1.4	2680	60000	0.90	7200	0.80	3380	60000	
C 90 4_582.8	582.8	1.5	7200	1.3	2750	60000	0.90	7200	0.70	3500	60000	
C 90 4_652.8	652.8	1.4	7200	1.1	2700	60000	0.80	7200	0.60	3450	60000	
C 90 4_712.2	712.2	1.3	7200	1.0	2760	60000	0.70	7200	0.60	3500	60000	
C 90 4_773.6	773.6	1.2	7200	1.0	2720	60000	0.60	7200	0.50	3480	60000	
C 90 4_844.0	844.0	1.1	7200	0.90	2790	60000	0.60	7200	0.50	3500	60000	
C 90 4_922.3	922.3	1.0	7200	0.80	2730	60000	0.50	7200	0.40	3490	60000	
C 90 4_1006	1006	0.90	7200	0.70	2800	60000	0.50	7200	0.40	3500	60000	
C 90 4_1137	1137	0.80	7200	0.70	2740	60000	0.40	7200	0.40	3500	60000	
C 90 4_1240	1240	0.70	7200	0.60	2800	60000	0.40	7200	0.30	3500	60000	





# C 100

# 12000 Nm

	i	n <sub>1</sub> = 2800 min <sup>-1</sup>					n <sub>1</sub> = 1400 min <sup>-1</sup>					
		n <sub>2</sub> min <sup>-1</sup>	M <sub>n2</sub> Nm	P <sub>n1</sub> kW	R <sub>n1</sub> N	R <sub>n2</sub> N	n <sub>2</sub> min <sup>-1</sup>	M <sub>n2</sub> Nm	P <sub>n1</sub> kW	R <sub>n1</sub> N	R <sub>n2</sub> N	
<b>C 100 2_4.9</b>	4.9	569	5500	345	1900	20600	285	6800	213	3790	25300	143
<b>C 100 2_5.3</b>	5.3	525	5650	327	2790	21000	263	6950	201	4940	25800	
<b>C 100 2_6.5</b>	6.5	429	6150	291	1920	21800	215	7550	179	3950	27000	
<b>C 100 2_7.1</b>	7.1	396	6200	271	3100	22700	198	7650	167	5270	27900	
<b>C 100 2_8.4</b>	8.4	335	6700	248	1870	22800	168	8200	152	3970	28500	
<b>C 100 2_9.0</b>	9.0	309	6800	232	2950	23500	155	8350	142	5190	29200	
<b>C 100 2_10.1</b>	10.1	278	7100	217	1930	24100	139	8750	134	3900	29500	
<b>C 100 2_10.9</b>	10.9	256	7100	200	3240	25700	128	8750	124	5460	31600	
<b>C 100 2_12.5</b>	12.5	225	7650	190	1360	24900	112	9400	117	3260	30800	
<b>C 100 2_13.5</b>	13.5	208	7700	176	2600	26300	104	9500	109	4680	32100	
<b>C 100 2_15.2</b>	15.2	184	8100	164	1270	26600	92	10000	101	2680	32500	
<b>C 100 2_16.5</b>	16.5	170	8250	154	2320	27200	85	10150	95	4420	33600	
<b>C 100 2_18.7</b>	18.7	150	8200	136	1500	30800	75	10000	83	3600	38000	
<b>C 100 2_20.2</b>	20.2	138	8100	124	3047	32200	69	10000	76	5210	39600	
<b>C 100 2_22.2</b>	22.2	126	7500	104	3570	35800	63	9200	64	5960	44100	
<b>C 100 2_24.1</b>	24.1	116	8100	104	3620	35200	58	10000	64	5900	43300	
<b>C 100 2_29.6</b>	29.6	95	6900	72	6380	42400	47	8500	44	9220	52200	
<b>C 100 3_34.3</b>	34.3	82	10350	95	9790	33300	41	11700	54	13000	46400	
<b>C 100 3_36.9</b>	36.9	76	10650	91	10200	34500	38	11800	50	13100	48000	
<b>C 100 3_42.9</b>	42.9	65	11350	83	9640	33200	33	12000	44	13100	51200	
<b>C 100 3_46.2</b>	46.2	61	11700	80	10100	33100	30	12000	41	13300	53100	
<b>C 100 3_53.3</b>	53.3	53	12000	71	9450	36400	26.3	12000	36	13200	56900	
<b>C 100 3_57.4</b>	57.4	49	12000	66	10200	39500	24.4	12000	33	13400	59000	
<b>C 100 3_64.5</b>	64.5	43	12000	59	9950	44100	21.7	12000	29	13400	62300	
<b>C 100 3_69.4</b>	69.4	40	12000	54	10400	45900	20.2	12000	27	13500	64500	
<b>C 100 3_79.4</b>	79.4	35	12000	48	10300	49200	17.6	12000	24	13500	68600	
<b>C 100 3_85.6</b>	85.6	33	12000	44	10400	51100	16.4	12000	22	13600	70900	
<b>C 100 3_92.7</b>	92.7	30	12000	41	10400	53200	15.1	12000	20	13500	73500	
<b>C 100 3_99.8</b>	99.8	28.1	12000	38	10500	55200	14.0	12000	19.0	13600	75900	
<b>C 100 3_111.9</b>	111.9	25.0	12000	34	10400	58300	12.5	12000	16.9	13500	79800	
<b>C 100 3_120.5</b>	120.5	23.2	12000	31	10500	60400	11.6	12000	15.7	13700	82400	
<b>C 100 3_139.7</b>	139.7	20.0	11050	25	10600	67400	10.0	11050	12.5	13700	85000	
<b>C 100 3_150.4</b>	150.4	18.6	12000	25	10600	66900	9.3	12000	12.6	13700	85000	
<b>C 100 4_162.1</b>	162.1	17.3	12000	24	—	85000	8.6	12000	11.9	—	85000	
<b>C 100 4_185.4</b>	185.4	15.1	12000	21	—	85000	7.6	12000	10.4	—	85000	
<b>C 100 4_199.6</b>	199.6	14.0	12000	19.4	—	85000	7.0	12000	9.7	—	85000	
<b>C 100 4_244.2</b>	244.2	11.5	12000	15.8	—	85000	5.7	12000	7.9	—	85000	
<b>C 100 4_263.0</b>	263.0	10.6	12000	14.7	—	85000	5.3	12000	7.4	—	85000	
<b>C 100 4_300.5</b>	300.5	9.3	12000	12.9	—	85000	4.7	12000	6.4	—	85000	
<b>C 100 4_323.6</b>	323.6	8.7	12000	11.9	—	85000	4.3	12000	6.0	—	85000	
<b>C 100 4_380.5</b>	380.5	7.4	12000	10.2	—	85000	3.7	12000	5.1	—	85000	
<b>C 100 4_409.8</b>	409.8	6.8	12000	9.4	—	85000	3.4	12000	4.7	—	85000	
<b>C 100 4_466.7</b>	466.7	6.0	12000	8.3	—	85000	3.0	12000	4.1	—	85000	
<b>C 100 4_502.6</b>	502.6	5.6	12000	7.7	—	85000	2.8	12000	3.8	—	85000	
<b>C 100 4_582.6</b>	582.6	4.8	12000	6.6	—	85000	2.4	12000	3.3	—	85000	
<b>C 100 4_627.4</b>	627.4	4.5	12000	6.2	—	85000	2.2	12000	3.1	—	85000	
<b>C 100 4_720.3</b>	720.3	3.9	12000	5.4	—	85000	1.9	12000	2.7	—	85000	
<b>C 100 4_775.7</b>	775.7	3.6	12000	5.0	—	85000	1.8	12000	2.5	—	85000	
<b>C 100 4_843.3</b>	843.3	3.3	12000	4.6	—	85000	1.7	12000	2.3	—	85000	
<b>C 100 4_908.2</b>	908.2	3.1	12000	4.3	—	85000	1.5	12000	2.1	830	85000	
<b>C 100 4_1004</b>	1004	2.8	12000	3.9	—	85000	1.4	12000	1.9	—	85000	
<b>C 100 4_1081</b>	1081	2.6	12000	3.6	—	85000	1.3	12000	1.8	870	85000	

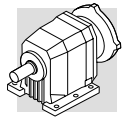
(-) Interpellare il ns. servizio tecnico comunicando i dati relativi al carico radiale (senso di rotazione, orientamento, posizione)  
 (-) Contact our technical service department advising radial load data (rotation direction, load angle, offset)  
 (-) Nehmen Sie bitte Kontakt mit unserem Applikationsdienst und Querkraftsdaten angeben (Drehrichtung, Orientierung, Anordnung)  
 (-) Consulter notre service technique en donnant les détails concernant la charge radiale (sens de rotation, indexage, position)



	i	$n_1 = 900 \text{ min}^{-1}$					$n_1 = 500 \text{ min}^{-1}$					
		$n_2$ $\text{min}^{-1}$	$M_{n2}$ Nm	$P_{n1}$ kW	$R_{n1}$ N	$R_{n2}$ N	$n_2$ $\text{min}^{-1}$	$M_{n2}$ Nm	$P_{n1}$ kW	$R_{n1}$ N	$R_{n2}$ N	
<b>C 100 2_4.9</b>	4.9	183	7800	157	5310	28800	102	9300	104	6720	34400	143
<b>C 100 2_5.3</b>	5.3	169	7950	148	6680	29500	94	9450	98	9740	35200	
<b>C 100 2_6.5</b>	6.5	138	8600	131	5670	31000	77	10250	87	7540	37000	
<b>C 100 2_7.1</b>	7.1	127	8750	123	7050	31800	71	10450	81	10100	37800	
<b>C 100 2_8.4</b>	8.4	108	9350	111	5670	32600	60	10950	72	8530	40100	
<b>C 100 2_9.0</b>	9.0	99	9500	104	7080	33600	55	11350	69	10100	39900	
<b>C 100 2_10.1</b>	10.1	89	10000	98	5540	33600	50	10900	60	10600	44500	
<b>C 100 2_10.9</b>	10.9	82	10150	92	6980	34700	46	11500	58	11300	44300	
<b>C 100 2_12.5</b>	12.5	72	10700	85	3910	35400	40	10850	48	11700	49600	
<b>C 100 2_13.5</b>	13.5	67	10850	80	6440	36700	37	11450	47	12300	49500	
<b>C 100 2_15.2</b>	15.2	59	10800	70	5940	40800	33	10800	39	13000	54700	
<b>C 100 2_16.5</b>	16.5	55	11500	69	6320	39100	30	11500	38	13400	54500	
<b>C 100 2_18.7</b>	18.7	48	10900	58	6310	45100	26.8	10900	32	13400	59800	
<b>C 100 2_20.2</b>	20.2	45	11500	56	6890	45000	24.7	11500	31	14000	60100	
<b>C 100 2_22.2</b>	22.2	40	9850	44	9170	52200	22.5	9850	24	15000	67800	
<b>C 100 2_24.1</b>	24.1	37	10800	44	8930	51200	20.7	10800	25	15000	67200	
<b>C 100 2_29.6</b>	29.6	30	9100	31	12600	61400	16.9	9100	17.0	15000	78300	
<b>C 100 3_34.3</b>	34.3	26.2	11700	35	15000	57800	14.6	11700	19.2	15000	75500	
<b>C 100 3_36.9</b>	36.9	24.4	11800	32	15000	59600	13.5	11800	18.0	15000	77700	
<b>C 100 3_42.9</b>	42.9	21.0	12000	28	15000	63400	11.6	12000	15.7	15000	82300	
<b>C 100 3_46.2</b>	46.2	19.5	12000	26	15000	65600	10.8	12000	14.6	15000	84900	
<b>C 100 3_53.3</b>	53.3	16.9	12000	23	15000	69900	9.4	12000	12.7	15000	85000	
<b>C 100 3_57.4</b>	57.4	15.7	12000	21	15000	72300	8.7	12000	11.8	15000	85000	
<b>C 100 3_64.5</b>	64.5	14.0	12000	18.6	15000	76100	7.8	12000	10.5	15000	85000	
<b>C 100 3_69.4</b>	69.4	13.0	12000	17.5	15000	78600	7.2	12000	9.7	15000	85000	
<b>C 100 3_79.4</b>	79.4	11.3	12000	15.3	15000	83300	6.3	12000	8.5	15000	85000	
<b>C 100 3_85.6</b>	85.6	10.5	12000	14.2	15000	85000	5.8	12000	7.9	15000	85000	
<b>C 100 3_92.7</b>	92.7	9.7	12000	13.1	15000	85000	5.4	12000	7.3	15000	85000	
<b>C 100 3_99.8</b>	99.8	9.0	12000	12.2	15000	85000	5.0	12000	6.8	15000	85000	
<b>C 100 3_111.9</b>	111.9	8.0	12000	10.9	15000	85000	4.5	12000	6.0	15000	85000	
<b>C 100 3_120.5</b>	120.5	7.5	12000	10.1	15000	85000	4.1	12000	5.6	15000	85000	
<b>C 100 3_139.7</b>	139.7	6.4	11500	8.0	15000	85000	3.6	11050	4.5	15000	85000	
<b>C 100 3_150.4</b>	150.4	6.0	12000	8.1	15000	85000	3.3	12000	4.5	15000	85000	
<b>C 100 4_162.1</b>	162.1	5.6	12000	7.7	—	85000	3.1	12000	4.3	—	85000	
<b>C 100 4_185.4</b>	185.4	4.9	12000	6.7	—	85000	2.7	12000	3.7	920	85000	
<b>C 100 4_199.6</b>	199.6	4.5	12000	6.2	—	85000	2.5	12000	3.5	1430	85000	
<b>C 100 4_244.2</b>	244.2	3.7	12000	5.1	—	85000	2.0	12000	2.8	1490	85000	
<b>C 100 4_263.0</b>	263.0	3.4	12000	4.7	—	85000	1.9	12000	2.6	1950	85000	
<b>C 100 4_300.5</b>	300.5	3.0	12000	4.1	—	85000	1.7	12000	2.3	1840	85000	
<b>C 100 4_323.6</b>	323.6	2.8	12000	3.8	850	85000	1.5	12000	2.1	2280	85000	
<b>C 100 4_380.5</b>	380.5	2.4	12000	3.3	700	85000	1.3	12000	1.8	2130	85000	
<b>C 100 4_409.8</b>	409.8	2.2	12000	3.0	1120	85000	1.2	12000	1.7	2550	85000	
<b>C 100 4_466.7</b>	466.7	1.9	12000	2.7	910	85000	1.1	12000	1.5	2340	85000	
<b>C 100 4_502.6</b>	502.6	1.8	12000	2.5	1320	85000	1.0	12000	1.4	2740	85000	
<b>C 100 4_582.6</b>	582.6	1.5	12000	2.1	1100	85000	0.90	12000	1.2	2520	85000	
<b>C 100 4_627.4</b>	627.4	1.4	12000	2.0	1490	85000	0.80	12000	1.1	2910	85000	
<b>C 100 4_720.3</b>	720.3	1.2	12000	1.7	1270	85000	0.70	12000	1.0	2700	85000	
<b>C 100 4_775.7</b>	775.7	1.2	12000	1.6	1650	85000	0.60	12000	0.90	3070	85000	
<b>C 100 4_843.3</b>	843.3	1.1	12000	1.5	1360	85000	0.60	12000	0.80	2790	85000	
<b>C 100 4_908.2</b>	908.2	1.0	12000	1.4	1730	85000	0.60	12000	0.80	3160	85000	
<b>C 100 4_1004</b>	1004	0.90	12000	1.2	1400	85000	0.50	12000	0.70	2830	85000	
<b>C 100 4_1081</b>	1081	0.90	12000	1.1	1770	85000	0.50	12000	0.60	3170	85000	

(-) Interpellare il ns. servizio tecnico comunicando i dati relativi al carico radiale (senso di rotazione, orientamento, posizione)  
 (-) Contact our technical service department advising radial load data (rotation direction, load angle, offset)  
 (-) Nehmen Sie bitte Kontakt mit unserem Applikationsdienst und Querkraftsdaten angeben (Drehrichtung, Orientierung, Anordnung)  
 (-) Consulter notre service technique en donnant les détails concernant la charge radiale (sens de rotation, indexage, position)



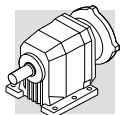

## 26 - PREDISPOSIZIONI POSSIBILI

Nelle tabelle (B20) e (B21) vengono riportati gli abbinamenti motore possibili in termini puramente geometrici.

La scelta del motoriduttore deve essere effettuata seguendo le istruzioni specificate al paragrafo 11, rispettando in particolare la condizione  $S \geq fs$ .

(B20)

## 26 - MOTOR AVAILABILITY

Motor-gearbox combinations resulting from charts (B20) and (B21) are purely based on geometrical compatibility.

When selecting a gearmotor, refer to procedure specified at para 11 and observe particularly the condition  $S \geq fs$ .

## 26 - ANBAUMÖGLICHKEITEN

In den Tabellen (B20) und (B21) werden die von den Größen her gesehenden möglichen Passungen angegeben.

Die angemessene Getriebewahl muss unter Befolgung der im Paragraph 11 gegebenen Anleitungen und auf der Grundlage der Auswahltablelle der technischen Daten erfolgen.

## 26 - PREDISPOSITIONS POSSIBLES

Dans les tableaux (B20) et (B21) sont indiqués les accouplements possibles en termes de dimensions.

Le choix le plus approprié du réducteur à utiliser doit être effectué selon les indications du paragraphe 11, ainsi qu'en fonction des caractéristiques techniques des tableaux de sélection.

		 IEC (IM B5)												
		P63	P71	P80	P90	P100	P112	P132	P160	P180	P200	P225	P250	P280
<b>C 11 2</b>		2.8_66.2	2.8_66.2	2.8_47.6	2.8_47.6	2.8_47.6	2.8_47.6							
<b>C 21 2</b>		3.7_63.3 ⊖ (6.4_7.1)	3.7_63.3 ⊖ (6.4_7.1)	2.7_54.7	2.7_54.7	2.7_54.7	2.7_54.7							
<b>C 21 3</b>		58.8_261.0	58.8_261.0	58.8_261.0	58.8_261.0	58.8_261.0	58.8_261.0							
<b>C 31 2</b>		5.0_66.8 ⊖ (6.5_9.3)	5.0_66.8 ⊖ (6.5_9.3)	2.9_66.8	2.9_66.8	2.9_66.8	2.9_66.8							
<b>C 31 3</b>		74.3_274.7	74.3_274.7	74.3_274.7	74.3_274.7	74.3_274.7	74.3_274.7							
<b>C 35 2</b>		4.6_19.0 ⊖ (6.1_8.8)	4.6_19.0 ⊖ (6.1_8.8)	2.7_19.0	2.7_19.0	2.7_19.0	2.7_19.0							
<b>C 35 3</b>		34.7_206.4	34.7_206.4	20.2_206.4	20.2_206.4	20.2_206.4	20.2_206.4							
<b>C 35 4</b>		232.3_848.5	232.3_848.5	232.3_848.5	232.3_848.5	232.3_848.5	232.3_848.5							
<b>C 41 2</b>		14.2_44.8	14.2_44.8	2.7_44.8	2.7_44.8	2.7_44.8	2.7_44.8	2.7_31.4						
<b>C 41 3</b>		47.0_209.1	47.0_209.1	28.5_209.1	28.5_209.1	28.5_209.1	28.5_209.1	28.5_102.3						
<b>C 41 4</b>		239.9_855.5	239.9_855.5	239.9_855.5	239.9_855.5	239.9_855.5	239.9_855.5							
<b>C 51 2</b>		18.9_57.0	18.9_57.0	2.6_57.0	2.6_57.0	2.6_57.0	2.6_57.0	2.6_40.4	2.6_40.4	2.6_40.4				
<b>C 51 3</b>		59.0_216.7	59.0_216.7	21.8_216.7	21.8_216.7	21.8_216.7	21.8_216.7	21.8_124.4	21.8_124.4	21.8_124.4				
<b>C 51 4</b>		240.9_884.9	240.9_884.9	240.9_884.9	240.9_884.9	240.9_884.9	240.9_884.9							
<b>C 61 2</b>	i =	22.4_38.0	22.4_38.0	3.7_38.0	3.7_38.0	3.7_38.0	3.7_38.0	2.8_38.0	2.8_38.0	2.8_38.0				
<b>C 61 3</b>		67.7_195.8	67.7_195.8	26.8_195.8	26.8_195.8	26.8_195.8	26.8_195.8	26.8_140.5	26.8_140.5	26.8_140.5				
<b>C 61 4</b>		217.4_796.1	217.4_796.1	217.4_796.1	217.4_796.1	217.4_796.1	217.4_796.1							
<b>C 70 2</b>				14.1_34.7 ⊖ (15.3)	14.1_34.7 ⊖ (15.3)	14.1_34.7 ⊖ (15.3)	14.1_34.7 ⊖ (15.3)	7.5_34.7 ⊖ (8.0)	4.6_34.7	4.6_34.7*	4.6_10.2* ⊖ (9.5)			
<b>C 70 3</b>		65.9_239.3	65.9_239.3	41.3_239.3	41.3_239.3	41.3_239.3	41.3_239.3	41.3_137.4	41.3_137.4	41.3_137.4*				
<b>C 70 4</b>		251.3_1476	251.3_1476	251.3_1476	251.3_1476	251.3_1476	251.3_1476	251.3_554.7						
<b>C 80 2</b>				20.5_39.1	20.5_39.1	20.5_39.1	20.5_39.1	11.1_39.1	7.0_39.1	5.6_31.3	5.6_25.9*	5.6_25.9*		
<b>C 80 3</b>				43.5_215.9	43.5_215.9	43.5_215.9	43.5_215.9	43.5_184.4	43.5_184.4	43.5_184.4				
<b>C 80 4</b>		334.3_1481	334.3_1481	261.9_1481	261.9_1481	261.9_1481	261.9_1481	261.9_724.7						
<b>C 90 2</b>				22.9_35.1	22.9_35.1	22.9_35.1	22.9_35.1	12.8_35.1	8.3_35.1	5.2_35.1	5.2_29.4	5.2_29.4*	5.2_29.4*	
<b>C 90 3</b>				74.4_172.1	74.4_172.1	74.4_172.1	74.4_172.1	39.4_172.1	39.4_172.1	39.4_172.1	39.4_96.2	39.4_96.2*	39.4_96.2*	
<b>C 90 4</b>		339.0_1240	339.0_1240	212.4_1240	212.4_1240	212.4_1240	212.4_1240	212.4_712.2	212.4_712.2	212.4_712.2				
<b>C 100 2</b>						29.6	29.6	15.2_29.6	12.5_29.6	12.5_29.6	4.9_29.6	4.9_29.6	4.9_29.6*	4.9_29.6*
<b>C 100 3</b>						79.4_150.4	79.4_150.4	42.9_150.4	34.3_150.4	34.3_120.5	34.3_99.8	34.3_99.8*	34.3_99.8	34.3_99.8*
<b>C 100 4</b>		380.5_1081	380.5_1081	162.1_1081	162.1_1081	162.1_1081	162.1_1081	162.1_775.7	162.1_775.7	162.1_775.7				

I motori nelle grandezze contrassegnate con \* vengono previsti in forma costruttiva B3/B5 nelle posizioni di montaggio B3-B5-B6-B7-B8.

For mounting position B3-B5 B6-B7-B8 the motor marked with \* will be supplied in B3/B5.

Für die Einbaulagen B3, B5 B6, B7, B8 werden die mit \* gekennzeichneten Motoren in Bauform B3/B5 geliefert.

Pour les positions de montage B3, B5, B6, B7, B8 les moteurs repérés par \* son livrés en B3/B5.

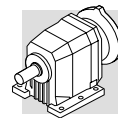

(B21)

									
		M0	M05	M1SD	M1L	M2	M3	M4	M5
<b>C 05 2</b>		27.1_44.7	5.5_44.7	5.5_44.7	5.5_44.7				
<b>C 11 2</b>			2.8_66.2	2.8_66.2	2.8_66.2	2.8_47.7	2.8_47.7		
<b>C 21 2</b>			2.8_63.3 ⊖ (6.4_7.1)	3.7_63.3 ⊖ (6.4_7.1)	3.7_63.3 ⊖ (6.4_7.1)	2.7_54.7	2.7_54.7		
<b>C 21 3</b>			58.8_261.0	58.8_261.0	58.8_261.0	58.8_261.0	58.8_261.0		
<b>C 31 2</b>				5.0_66.8 ⊖ (6.5_9.3)	5.0_66.8 ⊖ (6.5_9.3)	2.9_66.8	2.9_66.8		
<b>C 31 3</b>			74.3_274.7	74.3_274.7	74.3_274.7	74.3_274.7	74.3_274.7		
<b>C 35 2</b>				4.6_19.0 ⊖ (6.1_8.8)	4.6_19.0 ⊖ (6.1_8.8)	2.7_19.0	2.7_19.0		
<b>C 35 3</b>				34.7_206.4	34.7_206.4	20.2_206.4	20.2_206.4		
<b>C 35 4</b>			232.3_848.5	232.3_848.5	232.3_848.5	232.3_848.5	232.3_848.5		
<b>C 41 2</b>				14.2_44.8	2.7_44.8	2.7_44.8	2.7_44.8	2.7_31.4	
<b>C 41 3</b>				47.0_209.1	47.0_209.1	28.5_209.1	28.5_209.1	28.5_102.3	
<b>C 41 4</b>			239.9_855.5	239.9_855.5	239.9_855.5	239.9_855.5	239.9_855.5		
<b>C 51 2</b>				18.9_57.0	18.9_57.0	2.6_57.0	2.6_57.0	2.6_40.4	
<b>C 51 3</b>				59.0_216.7	59.0_216.7	21.8_216.7	21.8_216.7	21.8_124.4	
<b>C 51 4</b>	i =			240.9_884.9	240.9_884.9	240.9_884.9	240.9_884.9		
<b>C 61 2</b>						3.7_38.0	3.7_38.0	2.8_38.0	2.8_38.0
<b>C 61 3</b>						26.8_195.8	26.8_195.8	26.8_140.5	26.8_140.5
<b>C 61 4</b>				217.4_796.1	217.4_796.1	217.4_796.1	217.4_796.1		
<b>C 70 2</b>						14.1_34.7 ⊖ (15.3)	14.1_34.7 ⊖ (15.3)	7.5_34.7 ⊖ (8.0)	7.5_34.7 ⊖ (8.0)
<b>C 70 3</b>						41.3_239.3	41.3_239.3	41.3_137.4	41.3_137.4
<b>C 70 4</b>				251.3_1476	251.3_1476	251.3_1476	251.3_1476	251.3_554.7	
<b>C 80 2</b>							20.5_39.1	11.1_39.1	11.1_39.1
<b>C 80 3</b>							43.5_215.8	43.5_184.4	43.5_184.4
<b>C 80 4</b>				334.3_1481	261.9_1481	261.9_1481	261.9_1481	261.9_724.7	
<b>C 90 2</b>							22.9_35.1	12.8_35.1	12.8_35.1
<b>C 90 3</b>							74.4_172.1	39.4_172.1	39.4_172.1
<b>C 90 4</b>					339.0_1240	212.4_1240	212.4_1240	212.4_712.2	
<b>C 100 2</b>								15.2_29.6	15.2_29.6
<b>C 100 3</b>								42.9_150.4	42.9_150.4
<b>C 100 4</b>					380.5_1081	162.1_1081	162.1_1081	162.1_775.7	

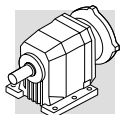

## 27 - MOMENTO D'INERZIA

## 27 - MOMENT OF INERTIA

## 27 - TRÄGHEITSMOMENT

## 27 - MOMENT D'INERTIE

Le tabelle seguenti indicano i valori del momento d'inerzia  $J_r$  [ $\text{Kgm}^2$ ] riferiti all'asse veloce del riduttore; per una migliore facilità di lettura riportiamo le definizioni dei simboli usati.

The following charts indicate moment of inertia values  $J_r$  [ $\text{Kgm}^2$ ] referred to the gear unit high speed shaft. A key to the symbols used follows:

Die In den folgenden Tabellen angegebenen Trägheitsmomente  $J_r$  [ $\text{Kgm}^2$ ] beziehen sich auf die Getriebeantriebsachse. Um das Lesen der Tabellen zu erleichtern, werden folgende Symbole verwendet:

Les tableaux suivants indiquent les valeurs du moment d'inertie  $J_r$  [ $\text{Kgm}^2$ ] du niveau de l'arbre rapide du réducteur; pour une plus grande facilité de lecture, nous vous prions de noter les définitions des symboles employés.



I valori riferiti a questo simbolo sono da attribuire al riduttore compatto senza motore. In questo caso, per avere il momento d'inerzia complessivo del motoriduttore, si dovrà sommare il valore corrispondente al riduttore compatto, a quello del motore da applicare (dato reperibile nelle tabelle delle caratteristiche tecniche dei motori elettrici).

Values under this icon refer to compact gear units, without motor.

To obtain the overall moment of inertia for the gearmotor just add the value of the inertia for the specific M style motor, given in the relevant rating chart.

Kompaktgetriebe ohne Motor. In diesem Fall muß man, um das Gesamtträgheitsmoment des Getriebemotors zu erhalten, den dem Kompaktgetriebe mit der gewählten Übersetzung entsprechenden Wert mit dem Wert des anzuschließenden Motors addieren (dieser Wert kann den Elektromotorenauswahltabellen entnommen werden).

Les valeurs liées à symbole sont à assigner au réducteur compact sans moteur. Dans ce cas, afin d'avoir le moment d'inertie total du motoréducteur, on devra additionner la valeur correspondant au réducteur compact, à celle du moteur à assembler (donnée que l'on peut repérer dans les tableaux des caractéristiques techniques des moteurs électriques).

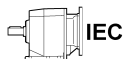

I valori relativi a questi simboli sono da attribuire al riduttore predisposto per attacco motore (grandezza IEC...).

Values under this symbol refer to gearboxes with IEC motor adaptor (IEC size...).

Nur Getriebe vorbereitet für IEC-Motor (IEC-Größe...).

Les valeurs liées à ces symboles sont à assigner au réducteur préparé pour accouplement moteur seulement (taille CEI...).





I valori attribuiti al riduttore sono riferiti a questo simbolo.

This symbol refers to gearbox values.



Dieses Symbol bezieht sich auf Getriebewerte.

Les valeurs liées au réducteur sont assignées à ce symbole.

## C 05

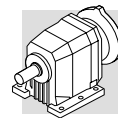

	i	$J (\cdot 10^{-4})$ [ $\text{Kgm}^2$ ]						
			63	71	80	90	100	
C 05_5.5	5.5	0.29	—	—	—	—	—	—
C 05_6.7	6.7	0.29	—	—	—	—	—	—
C 05_7.4	7.4	0.28	—	—	—	—	—	—
C 05_9.3	9.3	0.17	—	—	—	—	—	—
C 05_11.2	11.2	0.16	—	—	—	—	—	—
C 05_12.5	12.5	0.16	—	—	—	—	—	—
C 05_15.6	15.6	0.09	—	—	—	—	—	—
C 05_18.9	18.9	0.09	—	—	—	—	—	—
C 05_21.0	21.0	0.08	—	—	—	—	—	—
C 05_27.1	27.1	0.04	—	—	—	—	—	—
C 05_32.8	32.8	0.04	—	—	—	—	—	—
C 05_36.4	36.4	0.04	—	—	—	—	—	—
C 05_40.3	40.3	0.03	—	—	—	—	—	—
C 05_44.7	44.7	0.03	—	—	—	—	—	—



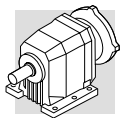



	i	J ( $\cdot 10^{-4}$ ) [Kgm <sup>2</sup> ]							
			 IEC						
			63	71	80	90	100	112	
C 11 2_2.8	2.8	0.44	1.9	1.9	3.3	3.2	4.5	4.5	1.3
C 11 2_3.7	3.7	0.29	1.8	1.7	3.1	3.1	4.4	4.4	1.2
C 11 2_4.9	4.9	0.19	1.7	1.7	3.0	3.0	4.3	4.3	1.1
C 11 2_6.2	6.2	0.12	1.6	1.6	3.0	2.9	4.2	4.2	1.0
C 11 2_6.9	6.9	0.34	1.8	1.8	3.2	3.1	4.4	4.4	1.2
C 11 2_7.6	7.6	0.33	1.8	1.8	3.2	3.1	4.4	4.4	1.2
C 11 2_9.1	9.1	0.23	1.7	1.7	3.1	3.0	4.3	4.3	1.1
C 11 2_10.1	10.1	0.23	1.7	1.7	3.1	3.0	4.3	4.3	1.1
C 11 2_12.1	12.1	0.16	1.6	1.6	3.0	3.0	4.2	4.2	1.1
C 11 2_13.4	13.4	0.16	1.6	1.6	3.0	2.9	4.2	4.2	1.1
C 11 2_15.5	15.5	0.10	1.6	1.6	2.9	2.9	4.2	4.2	1.0
C 11 2_17.2	17.2	0.10	1.6	1.6	2.9	2.9	4.2	4.2	1.0
C 11 2_18.6	18.6	0.08	1.5	1.5	2.9	2.9	4.2	4.2	1.0
C 11 2_20.6	20.6	0.08	1.5	1.5	2.9	2.9	4.2	4.2	1.0
C 11 2_22.8	22.8	0.06	1.5	1.5	2.9	2.8	4.1	4.1	1.0
C 11 2_25.4	25.4	0.06	1.5	1.5	2.9	2.8	4.1	4.1	1.0
C 11 2_29.5	29.5	0.04	1.5	1.5	2.9	2.8	4.1	4.1	0.9
C 11 2_32.8	32.8	0.04	1.5	1.5	2.9	2.8	4.1	4.1	0.9
C 11 2_33.4	33.4	0.03	1.5	1.5	2.9	2.8	4.1	4.1	0.9
C 11 2_37.0	37.0	0.03	1.5	1.5	2.9	2.8	4.1	4.1	0.9
C 11 2_42.9	42.9	0.02	1.5	1.5	1.9	1.8	4.1	4.1	0.9
C 11 2_47.6	47.6	0.02	1.5	1.5	2.9	2.8	4.1	4.1	0.9
C 11 2_49.7	49.7	0.02	1.5	1.5	2.9	2.8	4.1	4.1	0.9
C 11 2_55.2	55.2	0.02	1.5	1.5	2.9	2.8	4.1	4.1	0.9
C 11 2_59.6	59.6	0.01	1.5	1.5	2.9	2.8	4.1	4.1	0.9
C 11 2_66.2	66.2	0.01	1.5	1.5	2.9	2.8	4.1	4.1	0.9

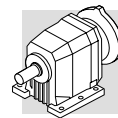

# C 21



	i	J ( $\cdot 10^{-4}$ ) [Kgm <sup>2</sup> ]							
			 IEC						
			63	71	80	90	100		
C 21 2_2.7	2.7	1.19	2.7	2.7	4.0	4.0	5.3	5.3	3.1
C 21 2_3.7	3.7	0.72	2.2	2.2	3.6	3.5	4.8	4.8	2.6
C 21 2_4.8	4.8	0.48	2.0	1.9	3.3	3.3	4.6	4.6	2.4
C 21 2_6.1	6.1	0.29	1.8	1.7	3.1	3.1	4.4	4.4	2.2
C 21 2_6.4	6.4	0.79	2.3	2.3	3.6	3.6	4.9	4.9	2.7
C 21 2_7.1	7.1	0.77	2.2	2.2	3.6	3.6	4.8	4.8	2.6
C 21 2_8.7	8.7	0.51	2.0	2.0	3.4	3.3	4.6	4.6	2.4
C 21 2_9.6	9.6	0.50	2.0	2.0	3.3	3.3	4.6	4.6	2.4
C 21 2_11.2	11.2	0.36	1.8	1.8	3.2	3.1	4.4	4.4	2.2
C 21 2_12.4	12.4	0.35	1.8	1.8	3.2	3.1	4.4	4.4	2.2
C 21 2_14.3	14.3	0.21	1.7	1.7	3.1	3.0	4.3	4.3	2.1
C 21 2_15.8	15.8	0.20	1.7	1.7	3.1	3.0	4.3	4.3	2.1
C 21 2_18.0	18/0	0.15	1.6	1.6	3.0	2.9	4.2	4.2	2.0
C 21 2_20.0	20.0	0.15	1.6	1.6	3.0	2.9	4.2	4.2	2.0
C 21 2_21.9	21.9	0.12	1.6	1.6	3.0	2.9	4.2	4.2	2.0
C 21 2_24.3	24.3	0.12	1.6	1.6	3.0	2.9	4.2	4.2	2.0
C 21 2_26.7	26.7	0.09	1.6	1.5	2.9	2.9	4.2	4.2	2.0
C 21 2_29.6	29.6	0.09	1.6	1.5	2.9	2.9	4.2	4.2	2.0
C 21 2_33.1	33.1	0.06	1.5	1.5	2.9	2.8	4.1	4.1	1.9
C 21 2_36.8	36.8	0.06	1.5	1.5	2.9	2.8	4.1	4.1	1.9
C 21 2_39.0	39.0	0.05	1.5	1.5	2.9	2.8	4.1	4.1	1.9
C 21 2_43.3	43.3	0.05	1.5	1.5	2.9	2.8	4.1	4.1	1.9
C 21 2_49.3	49.3	0.03	1.5	1.5	2.9	2.8	4.1	4.1	1.9
C 21 2_54.7	54.7	0.03	1.5	1.5	2.9	2.8	4.1	4.1	1.9
C 21 2_57.0	57.0	0.02	1.5	1.5	2.9	2.8	4.1	4.1	1.9
C 21 2_63.3	63.3	0.02	1.5	1.5	2.9	2.8	4.1	4.1	1.9
C 21 3_74.4	74.4	0.03	1.5	1.5	2.9	2.8	4.1	4.1	0.93
C 21 3_82.6	82.6	0.03	1.5	1.5	2.9	2.8	4.1	4.1	0.93
C 21 3_90.2	90.2	0.03	1.5	1.5	2.9	2.8	4.1	4.1	0.93
C 21 3_100.2	100.2	0.03	1.5	1.5	2.9	2.8	4.1	4.1	0.93
C 21 3_110.0	110.0	0.03	1.5	1.5	2.9	2.8	4.1	4.1	0.93
C 21 3_122.2	122.2	0.03	1.5	1.5	2.9	2.8	4.1	4.1	0.93
C 21 3_136.5	136.5	0.02	1.5	1.5	2.9	2.8	4.1	4.1	0.92
C 21 3_151.7	151.7	0.02	1.5	1.5	2.9	2.8	4.1	4.1	0.92
C 21 3_160.7	160.7	0.02	1.5	1.5	2.9	2.8	4.1	4.1	0.92
C 21 3_178.5	178.5	0.02	1.5	1.5	2.9	2.8	4.1	4.1	0.92
C 21 3_203.2	203.2	0.02	1.5	1.5	2.9	2.8	4.1	4.1	0.92
C 21 3_225.8	225.8	0.02	1.5	1.5	2.9	2.8	4.1	4.1	0.92
C 21 3_235.0	235.0	0.02	1.5	1.5	2.9	2.8	4.1	4.1	0.92
C 21 3_261.0	261.0	0.02	1.5	1.5	2.9	2.8	4.1	4.1	0.92



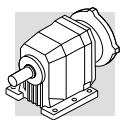



	i	J ( $\cdot 10^{-4}$ ) [Kgm <sup>2</sup> ]							
			IEC 						
			63	71	80	90	100	112	
C 31 2_2.9	2.9	2.3	3.8	3.8	5.2	5.1	6.4	6.4	4.6
C 31 2_3.7	3.7	1.6	3.0	3.0	4.4	4.3	5.6	5.6	3.8
C 31 2_5.0	5.0	0.87	2.3	2.3	3.7	3.7	5.0	5.0	3.1
C 31 2_6.3	6.3	0.63	2.1	2.1	3.5	3.4	4.7	4.7	2.8
C 31 2_6.5	6.5	1.57	3.0	3.0	4.4	4.4	5.7	5.7	3.8
C 31 2_7.2	7.2	1.5	3.0	3.0	4.4	4.3	5.6	5.6	3.7
C 31 2_8.4	8.4	1.1	2.6	2.6	3.9	3.9	5.2	5.2	3.3
C 31 2_9.3	9.3	1.1	2.5	2.5	3.9	3.8	5.1	5.1	3.3
C 31 2_11.1	11.1	0.62	2.1	2.1	3.5	3.4	4.7	4.7	2.8
C 31 2_12.3	12.3	0.60	2.1	2.1	3.5	3.4	4.7	4.7	2.8
C 31 2_14.0	14.0	0.47	1.9	1.9	3.3	3.3	4.5	4.5	2.7
C 31 2_15.6	15.6	0.46	1.9	1.9	3.3	3.3	4.5	4.5	2.7
C 31 2_18.1	18.1	0.34	1.8	1.8	3.2	3.1	4.4	4.4	2.6
C 31 2_20.1	20.1	0.34	1.8	1.8	3.2	3.1	4.4	4.4	2.6
C 31 2_22.6	22.6	0.25	1.7	1.7	3.1	3.0	4.3	4.3	2.5
C 31 2_25.1	25.1	0.25	1.7	1.7	3.1	3.0	4.3	4.3	2.5
C 31 2_26.8	26.8	0.20	1.7	1.7	3.0	3.0	4.3	4.3	2.4
C 31 2_29.8	29.8	0.19	1.7	1.7	3.0	3.0	4.3	4.3	2.4
C 31 2_32.5	32.5	0.14	1.6	1.6	3.0	2.9	4.2	4.2	2.4
C 31 2_36.1	36.1	0.14	1.6	1.6	3.0	2.9	4.2	4.2	2.4
C 31 2_40.7	40.7	0.10	1.6	1.6	3.0	2.9	4.2	4.2	2.3
C 31 2_45.3	45.3	0.10	1.6	1.6	3.0	2.9	4.2	4.2	2.3
C 31 2_47.2	47.2	0.08	1.6	1.5	2.9	2.9	4.2	4.2	2.3
C 31 2_52.4	52.4	0.08	1.6	1.5	2.9	2.9	4.2	4.2	2.3
C 31 2_60.2	60.2	0.05	1.5	1.5	2.9	2.8	4.1	4.1	2.3
C 31 2_66.8	66.8	0.05	1.5	1.5	2.9	2.8	4.1	4.1	2.3
C 31 3_74.3	74.3	0.06	1.5	1.5	2.9	2.8	4.1	4.1	0.96
C 31 3_82.6	82.6	0.06	1.5	1.5	2.9	2.8	4.1	4.1	0.96
C 31 3_93.0	93.0	0.05	1.5	1.5	2.9	2.8	4.1	4.1	0.95
C 31 3_103.3	103.3	0.05	1.5	1.5	2.9	2.8	4.1	4.1	0.95
C 31 3_110.2	110.2	0.05	1.5	1.5	2.9	2.8	4.1	4.1	0.95
C 31 3_122.4	122.4	0.05	1.5	1.5	2.9	2.8	4.1	4.1	0.95
C 31 3_133.6	133.6	0.05	1.5	1.5	2.9	2.8	4.1	4.1	0.95
C 31 3_148.4	148.4	0.05	1.5	1.5	2.9	2.8	4.1	4.1	0.95
C 31 3_167.5	167.5	0.04	1.5	1.5	2.9	2.8	4.1	4.1	0.94
C 31 3_186.0	186.0	0.04	1.5	1.5	2.9	2.8	4.1	4.1	0.94
C 31 3_194.1	194.1	0.04	1.5	1.5	2.9	2.8	4.1	4.1	0.94
C 31 3_215.6	215.6	0.04	1.5	1.5	2.9	2.8	4.1	4.1	0.94
C 31 3_247.3	247.3	0.04	1.5	1.5	2.9	2.8	4.1	4.1	0.94
C 31 3_274.7	274.7	0.04	1.5	1.5	2.9	2.8	4.1	4.1	0.94

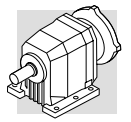

# C 35

	i	J ( $\cdot 10^{-4}$ ) [Kgm <sup>2</sup> ]							
			 IEC						
			63	71	80	90	100		
C 35 2_2.7	2.7	3.6	—	—	6.5	6.4	7.7	7.7	14.1
C 35 2_3.5	3.5	2.4	—	—	5.3	5.2	6.5	6.5	12.9
C 35 2_4.6	4.6	1.5	3.0	3.0	4.4	4.3	5.6	5.6	12.0
C 35 2_5.8	5.8	1.0	2.5	2.5	3.9	3.8	5.1	5.1	11.5
C 35 2_6.1	6.1	2.3	—	—	5.2	5.1	6.4	6.4	12.8
C 35 2_6.8	6.8	2.2	—	—	5.1	5.0	6.3	6.3	12.7
C 35 2_7.9	7.9	1.6	—	—	4.5	4.4	5.7	5.7	12.1
C 35 2_8.8	8.8	1.5	—	—	4.4	4.3	5.6	5.6	12.0
C 35 2_10.5	10.5	1.1	2.6	2.6	4.0	3.9	5.2	5.2	11.6
C 35 2_11.7	11.7	1.0	2.5	2.5	3.9	3.8	5.1	5.1	11.5
C 35 2_13.3	13.3	0.7	2.2	2.2	3.6	3.5	4.8	4.8	11.2
C 35 2_14.8	14.8	0.59	2.1	2.1	3.5	3.4	4.7	4.7	11.1
C 35 2_17.1	17.1	0.49	2.0	2.0	3.4	3.3	4.6	4.6	11.0
C 35 2_19.0	19.0	0.47	2.0	2.0	3.4	3.3	4.6	4.6	11.0
C 35 3_20.2	20.2	1.7	—	—	4.6	4.5	5.8	5.8	12.2
C 35 3_22.1	22.1	1.7	—	—	4.6	4.5	5.8	5.8	12.2
C 35 3_26.2	26.2	1.2	—	—	4.1	4.0	5.3	5.3	11.7
C 35 3_28.7	28.7	1.2	—	—	4.1	4.0	5.3	5.3	11.7
C 35 3_34.7	34.7	0.8	2.3	2.3	3.7	3.6	4.9	4.9	11.3
C 35 3_38.1	38.1	0.8	2.3	2.3	3.7	3.6	4.9	4.9	11.3
C 35 3_43.9	43.9	0.5	2.0	2.0	3.4	3.3	4.6	4.6	11.0
C 35 3_48.2	48.2	0.5	2.0	2.0	3.4	3.3	4.6	4.6	11.0
C 35 3_56.5	56.5	0.38	1.9	1.9	3.3	3.2	4.5	4.5	10.9
C 35 3_62.0	62.0	0.41	1.9	1.9	3.3	3.2	4.5	4.5	10.9
C 35 3_70.7	70.7	0.28	1.8	1.8	3.2	3.1	4.4	4.4	10.8
C 35 3_77.6	77.6	0.28	1.8	1.8	3.2	3.1	4.4	4.4	10.8
C 35 3_83.8	83.8	0.21	1.7	1.7	3.1	3.0	4.3	4.3	10.7
C 35 3_91.9	91.9	0.21	1.7	1.7	3.1	3.0	4.3	4.3	10.7
C 35 3_101.6	101.6	0.16	1.7	1.7	3.1	3.0	4.3	4.3	10.7
C 35 3_111.5	111.5	0.16	1.7	1.7	3.1	3.0	4.3	4.3	10.7
C 35 3_127.3	127.3	0.11	1.6	1.6	3.0	2.9	4.2	4.2	10.6
C 35 3_139.8	139.8	0.11	1.6	1.6	3.0	2.9	4.2	4.2	10.6
C 35 3_147.6	147.6	0.09	1.6	1.6	3.0	2.9	4.2	4.2	10.6
C 35 3_162.0	162.0	0.09	1.6	1.6	3.0	2.9	4.2	4.2	10.6
C 35 3_188.0	188.0	0.06	1.6	1.6	3.0	2.9	4.2	4.2	10.6
C 35 3_206.4	206.4	0.06	1.6	1.6	3.0	2.9	4.2	4.2	10.6
C 35 4_232.3	232.3	0.08	1.6	1.6	3.0	2.9	4.2	4.2	0.9
C 35 4_255.0	255.0	0.08	1.6	1.6	3.0	2.9	4.2	4.2	0.9
C 35 4_290.6	290.6	0.07	1.6	1.6	3.0	2.9	4.2	4.2	0.9
C 35 4_318.9	318.9	0.07	1.6	1.6	3.0	2.9	4.2	4.2	0.9
C 35 4_344.3	344.3	0.06	1.6	1.6	3.0	2.9	4.2	4.2	0.9
C 35 4_377.9	377.9	0.06	1.6	1.6	3.0	2.9	4.2	4.2	0.9
C 35 4_417.6	417.6	0.06	1.6	1.6	3.0	2.9	4.2	4.2	0.9
C 35 4_458.4	458.4	0.06	1.6	1.6	3.0	2.9	4.2	4.2	0.9
C 35 4_523.5	523.5	0.06	1.6	1.6	3.0	2.9	4.2	4.2	0.9
C 35 4_574.7	574.7	0.06	1.6	1.6	3.0	2.9	4.2	4.2	0.9
C 35 4_606.6	606.6	0.06	1.6	1.6	3.0	2.9	4.2	4.2	0.9
C 35 4_665.9	665.9	0.06	1.6	1.6	3.0	2.9	4.2	4.2	0.9
C 35 4_773.0	773.0	0.06	1.6	1.6	3.0	2.9	4.2	4.2	0.9
C 35 4_848.5	848.5	0.06	1.6	1.6	3.0	2.9	4.2	4.2	0.9





	i	J ( $\cdot 10^{-4}$ ) [Kgm <sup>2</sup> ]								
			IEC 							
			63	71	80	90	100	112	132	
C 41 2_2.7	2.7	10.0	—	—	12.9	12.8	14.1	14.1	28.9	20.5
C 41 2_3.6	3.6	6.0	—	—	8.9	8.8	10.1	10.1	24.9	16.5
C 41 2_4.7	4.7	3.7	—	—	6.6	6.5	7.8	7.8	22.6	14.2
C 41 2_6.0	6.0	2.5	—	—	5.4	5.3	6.6	6.6	21.4	13.0
C 41 2_6.4	6.4	4.3	—	—	7.2	7.1	8.4	8.4	23.2	14.8
C 41 2_7.1	7.1	4.1	—	—	7.0	6.9	8.2	8.2	23.0	14.6
C 41 2_8.6	8.6	2.9	—	—	5.8	5.7	7.0	7.0	21.8	13.4
C 41 2_9.6	9.6	2.8	—	—	5.7	5.6	6.9	6.9	21.7	13.3
C 41 2_11.2	11.2	1.8	—	—	4.7	4.6	5.9	5.9	20.7	12.3
C 41 2_12.4	12.4	1.8	—	—	4.7	4.6	5.9	5.9	20.7	12.3
C 41 2_14.2	14.2	1.4	2.9	2.9	4.3	4.2	5.5	5.5	20.3	11.9
C 41 2_15.8	15.8	1.3	2.8	2.8	4.2	4.1	5.4	5.4	20.2	11.8
C 41 2_17.8	17.8	1.0	2.5	2.5	3.9	3.8	5.1	5.1	19.9	11.5
C 41 2_19.8	19.8	0.98	2.5	2.5	3.9	3.8	5.1	5.1	19.9	11.5
C 41 2_22.6	22.6	0.6	2.1	2.1	3.5	3.4	4.7	4.7	19.5	11.1
C 41 2_25.0	25.0	0.6	2.1	2.1	3.5	3.4	4.7	4.7	19.5	11.1
C 41 2_28.3	28.3	0.44	1.9	1.9	3.3	3.2	4.5	4.5	19.3	10.9
C 41 2_31.4	31.4	0.43	1.9	1.9	3.3	3.2	4.5	4.5	19.3	10.9
C 41 2_33.4	33.4	0.34	1.8	1.8	3.2	3.1	4.4	4.4	—	10.8
C 41 2_37.1	37.1	0.33	1.8	1.8	3.2	3.1	4.4	4.4	—	10.8
C 41 2_44.8	44.8	0.27	1.8	1.8	3.2	3.1	4.4	4.4	—	10.8
C 41 3_28.5	28.5	2.52	—	—	5.4	5.3	6.6	6.6	21.4	13.0
C 41 3_31.2	31.2	2.51	—	—	5.4	5.3	6.6	6.6	21.4	13.0
C 41 3_36.8	36.8	1.6	—	—	4.5	4.4	5.7	5.7	20.5	12.1
C 41 3_40.3	40.3	1.6	—	—	4.5	4.4	5.7	5.7	20.5	12.1
C 41 3_47.0	47.0	1.2	2.7	2.7	4.1	4.0	5.3	5.3	20.1	11.7
C 41 3_51.5	51.5	1.2	2.7	2.7	4.1	4.0	5.3	5.3	20.1	11.7
C 41 3_58.7	58.7	0.9	2.4	2.4	3.8	3.7	5.0	5.0	19.8	11.4
C 41 3_64.3	64.3	0.9	2.4	2.4	3.8	3.7	5.0	5.0	19.8	11.4
C 41 3_74.4	74.4	0.6	2.1	2.1	3.5	3.4	4.7	4.7	19.5	11.1
C 41 3_81.5	81.5	0.6	2.1	2.1	3.5	3.4	4.7	4.7	19.5	11.1
C 41 3_93.9	93.9	0.4	1.9	1.9	3.3	3.2	4.5	4.5	19.3	10.9
C 41 3_102.3	102.3	0.4	1.9	1.9	3.3	3.2	4.5	4.5	19.3	10.9
C 41 3_110.1	110.1	0.3	1.8	1.8	3.2	3.1	4.4	4.4	—	10.8
C 41 3_120.6	120.6	0.3	1.8	1.8	3.2	3.1	4.4	4.4	—	10.8
C 41 3_132.9	132.9	0.3	1.8	1.8	3.2	3.1	4.4	4.4	—	10.8
C 41 3_145.6	145.6	0.3	1.8	1.8	3.2	3.1	4.4	4.4	—	10.8
C 41 3_164.1	164.1	0.2	1.7	1.7	3.1	3.0	4.3	4.3	—	10.7
C 41 3_179.9	179.9	0.2	1.7	1.7	3.1	3.0	4.3	4.3	—	10.7
C 41 3_190.8	190.8	0.1	1.6	1.6	3.0	2.9	4.2	4.2	—	10.6
C 41 3_209.1	209.1	0.1	1.6	1.6	3.0	2.9	4.2	4.2	—	10.6
C 41 4_239.9	239.9	0.15	1.7	1.7	3.1	3.0	4.3	4.3	—	2.1
C 41 4_263.0	263.0	0.15	1.7	1.7	3.1	3.0	4.3	4.3	—	2.1
C 41 4_304.2	304.2	0.13	1.6	1.6	3.0	2.9	4.2	4.2	—	2.0
C 41 4_333.4	333.4	0.13	1.6	1.6	3.0	2.9	4.2	4.2	—	2.0
C 41 4_382.0	382.0	0.12	1.6	1.6	3.0	2.9	4.2	4.2	—	2.0
C 41 4_419.0	419.0	0.12	1.6	1.6	3.0	2.9	4.2	4.2	—	2.0
C 41 4_450.2	450.2	0.12	1.6	1.6	3.0	2.9	4.2	4.2	—	2.0
C 41 4_493.5	493.5	0.12	1.6	1.6	3.0	2.9	4.2	4.2	—	2.0
C 41 4_543.5	543.5	0.12	1.6	1.6	3.0	2.9	4.2	4.2	—	2.0
C 41 4_595.8	595.8	0.12	1.6	1.6	3.0	2.9	4.2	4.2	—	2.0
C 41 4_671.3	671.3	0.1	1.6	1.6	3.0	2.9	4.2	4.2	—	2.0
C 41 4_735.9	735.9	0.1	1.6	1.6	3.0	2.9	4.2	4.2	—	2.0
C 41 4_780.4	780.4	0.1	1.6	1.6	3.0	2.9	4.2	4.2	—	2.0
C 41 4_855.5	855.5	0.1	1.6	1.6	3.0	2.9	4.2	4.2	—	2.0

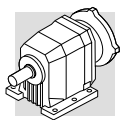





# C 51

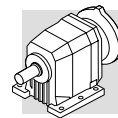

	i	J ( $\cdot 10^{-4}$ ) [Kgm <sup>2</sup> ]										
			 IEC									
			63	71	80	90	100	112	132	160		180
C 51 2_2.6	2.6	14.5	—	—	17.4	17.3	18.6	18.6	33.4	—	—	25.0
C 51 2_3.3	3.3	10.0	—	—	12.9	12.8	14.1	14.1	28.9	—	—	20.5
C 51 2_4.5	4.5	6.3	—	—	9.2	9.1	10.4	10.4	25.2	—	—	16.8
C 51 2_5.6	5.6	4.1	—	—	7.0	6.9	8.2	8.2	23.0	—	—	14.6
C 51 2_7.0	7.0	8.1	—	—	11.0	10.9	12.2	12.2	27.0	—	—	18.6
C 51 2_7.8	7.8	7.8	—	—	10.7	10.6	11.9	11.9	26.7	—	—	18.3
C 51 2_8.8	8.8	6.0	—	—	8.9	8.8	10.1	10.1	24.9	—	—	16.5
C 51 2_9.8	9.8	5.8	—	—	8.7	8.6	9.9	9.9	24.7	—	—	16.3
C 51 2_11.8	11.8	4.1	—	—	7.0	6.9	8.2	8.2	23.0	—	—	14.6
C 51 2_13.1	13.1	4.0	—	—	6.9	6.8	8.1	8.1	22.9	—	—	14.5
C 51 2_15.0	15.0	2.7	—	—	5.6	5.5	6.8	6.8	21.6	—	—	13.2
C 51 2_16.6	16.6	2.6	—	—	5.5	5.4	6.7	6.7	21.5	—	—	13.1
C 51 2_18.9	18.9	2.0	3.5	3.5	4.9	4.8	6.1	6.1	20.9	—	—	12.5
C 51 2_21.0	21.0	1.9	3.4	3.4	4.8	4.7	6.0	6.0	20.8	—	—	12.4
C 51 2_23.4	23.4	1.5	3.0	3.0	4.4	4.3	5.6	5.6	20.4	—	—	12.0
C 51 2_25.9	25.9	1.4	2.9	2.9	4.3	4.2	5.5	5.5	20.3	—	—	11.9
C 51 2_29.8	29.8	0.9	2.4	2.4	3.8	3.7	5.0	5.0	19.8	—	—	11.4
C 51 2_33.0	33.0	0.9	2.4	2.4	3.8	3.7	5.0	5.0	19.8	—	—	11.4
C 51 2_36.4	36.4	0.7	2.2	2.2	3.6	3.5	4.8	4.8	19.6	—	—	11.2
C 51 2_40.4	40.4	0.7	2.2	2.2	3.6	3.5	4.8	4.8	19.6	—	—	11.2
C 51 2_43.1	43.1	0.5	2.0	2.0	3.4	3.3	4.6	4.6	—	—	—	11.0
C 51 2_47.8	47.8	0.5	2.0	2.0	3.4	3.3	4.6	4.6	—	—	—	11.0
C 51 2_51.4	51.4	0.4	1.9	1.9	3.3	3.2	4.5	4.5	—	—	—	10.9
C 51 2_57.0	57.0	0.4	1.9	1.9	3.3	3.2	4.5	4.5	—	—	—	10.9
C 51 3_21.8	21.8	6.8	—	—	9.7	9.6	10.9	10.9	25.7	77.7	75.7	17.3
C 51 3_23.9	23.9	6.8	—	—	9.7	9.6	10.9	10.9	25.7	77.7	75.7	17.3
C 51 3_27.4	27.4	5.2	—	—	8.1	8.0	9.3	9.3	24.1	77.7	75.7	15.7
C 51 3_30.1	30.1	5.2	—	—	8.1	8.0	9.3	9.3	24.1	77.7	75.7	15.7
C 51 3_37.0	37.0	3.6	—	—	6.5	6.4	7.7	7.7	22.5	77.7	75.7	14.1
C 51 3_40.5	40.5	3.6	—	—	6.5	6.4	7.7	7.7	22.5	77.7	75.7	14.1
C 51 3_46.7	46.7	2.4	—	—	5.3	5.2	6.5	6.5	21.3	77.7	75.7	12.9
C 51 3_51.2	51.2	2.4	—	—	5.3	5.2	6.5	6.5	21.3	77.7	75.7	12.9
C 51 3_59.0	59.0	1.8	3.3	3.3	4.7	4.6	5.9	5.9	20.7	77.7	75.7	12.3
C 51 3_64.6	64.6	1.8	3.3	3.3	4.7	4.6	5.9	5.9	20.7	77.7	75.7	12.3
C 51 3_72.9	72.9	1.3	2.8	2.8	4.2	4.1	5.4	5.4	20.2	77.7	75.7	11.8
C 51 3_79.9	79.9	1.3	2.8	2.8	4.2	4.1	5.4	5.4	20.2	77.7	75.7	11.8
C 51 3_93.0	93.0	0.8	2.3	2.3	3.7	3.6	4.9	4.9	19.7	77.7	75.7	11.3
C 51 3_101.8	101.8	0.8	2.3	2.3	3.7	3.6	4.9	4.9	19.7	77.7	75.7	11.3
C 51 3_113.6	113.6	0.6	2.1	2.1	3.5	3.4	4.7	4.7	19.5	77.7	75.7	11.1
C 51 3_124.4	124.4	0.6	2.1	2.1	3.5	3.4	4.7	4.7	19.5	77.7	75.7	11.1
C 51 3_134.6	134.6	0.5	2.0	2.0	3.4	3.3	4.6	4.6	—	—	—	11.0
C 51 3_147.4	147.4	0.5	2.0	2.0	3.4	3.3	4.6	4.6	—	—	—	11.0
C 51 3_160.5	160.5	0.4	1.9	1.9	3.3	3.2	4.5	4.5	—	—	—	10.9
C 51 3_175.8	175.8	0.4	1.9	1.9	3.3	3.2	4.5	4.5	—	—	—	10.9
C 51 3_197.9	197.9	0.3	1.8	1.8	3.2	3.1	4.4	4.4	—	—	—	10.8
C 51 3_216.7	216.7	0.3	1.8	1.8	3.2	3.1	4.4	4.4	—	—	—	10.8
C 51 4_240.9	240.9	0.3	1.8	1.8	3.2	3.1	4.4	4.4	—	—	—	1.2
C 51 4_263.8	263.8	0.3	1.8	1.8	3.2	3.1	4.4	4.4	—	—	—	1.2
C 51 4_297.8	297.8	0.3	1.8	1.8	3.2	3.1	4.4	4.4	—	—	—	1.2
C 51 4_326.1	326.1	0.3	1.8	1.8	3.2	3.1	4.4	4.4	—	—	—	1.2
C 51 4_380.0	380.0	0.2	1.7	1.7	3.1	3.0	4.3	4.3	—	—	—	1.1
C 51 4_416.0	416.0	0.2	1.7	1.7	3.1	3.0	4.3	4.3	—	—	—	1.1
C 51 4_463.9	463.9	0.2	1.7	1.7	3.1	3.0	4.3	4.3	—	—	—	1.1
C 51 4_508.0	508.0	0.2	1.7	1.7	3.1	3.0	4.3	4.3	—	—	—	1.1
C 51 4_549.7	549.7	0.2	1.7	1.7	3.1	3.0	4.3	4.3	—	—	—	1.1
C 51 4_602.0	602.0	0.2	1.7	1.7	3.1	3.0	4.3	4.3	—	—	—	1.1
C 51 4_655.4	655.4	0.2	1.7	1.7	3.1	3.0	4.3	4.3	—	—	—	1.1
C 51 4_717.7	717.7	0.2	1.7	1.7	3.1	3.0	4.3	4.3	—	—	—	1.1
C 51 4_808.0	808.0	0.2	1.7	1.7	3.1	3.0	4.3	4.3	—	—	—	1.1
C 51 4_884.9	884.9	0.2	1.7	1.7	3.1	3.0	4.3	4.3	—	—	—	1.1



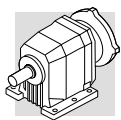

	i	J ( $\cdot 10^{-4}$ ) [Kgm <sup>2</sup> ]										
			 IEC									
			63	71	80	90	100	112	132	160		180
C 61 2_2.8	2.8	30	—	—	—	—	—	—	48.9	77.7	75.7	51.8
C 61 2_3.7	3.7	19	—	—	21.9	21.8	23.1	23.1	37.9	77.7	75.7	40.8
C 61 2_4.6	4.6	14	—	—	16.9	16.8	18.1	18.1	32.9	77.7	75.7	35.8
C 61 2_6.0	6.0	8.8	—	—	11.7	11.6	12.9	12.9	27.7	77.7	75.7	30.6
C 61 2_6.7	6.7	14	—	—	16.9	16.8	18.1	18.1	32.9	77.7	75.7	35.8
C 61 2_7.5	7.5	13	—	—	15.9	15.8	17.1	17.1	31.9	77.7	75.7	34.8
C 61 2_8.8	8.8	13	—	—	15.9	15.8	17.1	17.1	31.9	77.7	75.7	34.8
C 61 2_9.8	9.8	12	—	—	14.9	14.8	16.1	16.1	30.9	77.7	75.7	33.8
C 61 2_10.9	10.9	9.6	—	—	12.5	12.4	13.7	13.7	28.5	77.7	75.7	31.4
C 61 2_12.1	12.1	9.2	—	—	12.1	12.0	13.3	13.3	28.1	77.7	75.7	31.0
C 61 2_14.3	14.3	5.8	—	—	8.7	8.6	9.9	9.9	24.7	77.7	75.7	27.6
C 61 2_15.9	15.9	5.6	—	—	8.5	8.4	9.7	9.7	24.5	77.7	75.7	27.4
C 61 2_17.7	17.7	4.4	—	—	7.3	7.2	8.5	8.5	23.3	77.7	75.7	26.2
C 61 2_19.6	19.6	4.3	—	—	7.2	7.1	8.4	8.4	23.2	77.7	75.7	26.1
C 61 2_22.4	22.4	3.2	4.7	4.7	6.1	6.0	7.3	7.3	22.1	77.7	75.7	25.0
C 61 2_24.8	24.8	3.1	4.6	4.6	6.0	5.9	7.2	7.2	22.0	77.7	75.7	24.9
C 61 2_27.4	27.4	2.1	3.6	3.6	5.0	4.9	6.2	6.2	21.0	77.7	75.7	23.9
C 61 2_30.4	30.4	2.2	3.7	3.7	5.1	5.0	6.3	6.3	21.1	77.7	75.7	24.0
C 61 2_34.2	34.2	1.5	3.0	3.0	4.4	4.3	5.6	5.6	20.4	77.7	75.7	23.3
C 61 2_38.0	38.0	1.5	3.0	3.0	4.4	4.3	5.6	5.6	20.4	77.7	75.7	23.3
C 61 3_26.8	26.8	10	—	—	12.9	12.8	14.1	14.1	28.9	77.7	75.7	31.8
C 61 3_29.4	29.4	10	—	—	12.9	12.8	14.1	14.1	28.9	77.7	75.7	31.8
C 61 3_33.0	33.0	8.1	—	—	11.0	10.9	12.2	12.2	27.0	77.7	75.7	29.9
C 61 3_36.1	36.1	8.1	—	—	11.0	10.9	12.2	12.2	27.0	77.7	75.7	29.9
C 61 3_43.4	43.4	5.0	—	—	7.9	7.8	9.1	9.1	23.9	77.7	75.7	26.8
C 61 3_47.6	47.6	5.0	—	—	7.9	7.8	9.1	9.1	23.9	77.7	75.7	26.8
C 61 3_53.5	53.5	3.9	—	—	6.8	6.7	8.0	8.0	22.8	77.7	75.7	25.7
C 61 3_58.6	58.6	3.8	—	—	6.7	6.6	7.9	7.9	22.7	77.7	75.7	25.6
C 61 3_67.7	67.7	2.8	4.3	4.3	5.7	5.6	6.9	6.9	21.7	77.7	75.7	24.6
C 61 3_74.2	74.2	2.8	4.3	4.3	5.7	5.6	6.9	6.9	21.7	77.7	75.7	24.6
C 61 3_83.0	83.0	1.9	3.4	3.4	4.8	4.7	6.0	6.0	20.8	77.7	75.7	23.7
C 61 3_91.0	91.0	1.9	3.4	3.4	4.8	4.7	6.0	6.0	20.8	77.7	75.7	23.7
C 61 3_103.6	103.6	1.3	2.8	2.8	4.2	4.1	5.4	5.4	20.2	77.7	75.7	23.1
C 61 3_113.6	113.6	1.3	2.8	2.8	4.2	4.1	5.4	5.4	20.2	77.7	75.7	23.1
C 61 3_128.1	128.1	1.0	2.5	2.5	3.9	3.8	5.1	5.1	19.9	77.7	75.7	22.8
C 61 3_140.5	140.5	1.0	2.5	2.5	3.9	3.8	5.1	5.1	19.9	77.7	75.7	22.8
C 61 3_150.0	150.0	0.7	2.2	2.2	3.6	3.5	4.8	4.8	—	—	—	22.5
C 61 3_164.5	164.5	0.7	2.2	2.2	3.6	3.5	4.8	4.8	—	—	—	22.5
C 61 3_178.6	178.6	0.6	2.1	2.1	3.5	3.4	4.7	4.7	—	—	—	22.4
C 61 3_195.8	195.8	0.6	2.1	2.1	3.5	3.4	4.7	4.7	—	—	—	22.4
C 61 4_217.4	217.4	0.67	2.2	2.2	3.6	3.5	4.8	4.8	—	—	—	11.2
C 61 4_238.3	238.3	0.67	2.2	2.2	3.6	3.5	4.8	4.8	—	—	—	11.2
C 61 4_275.3	275.3	0.81	2.3	2.3	3.7	3.6	4.9	4.9	—	—	—	11.3
C 61 4_301.7	301.7	0.81	2.3	2.3	3.7	3.6	4.9	4.9	—	—	—	11.3
C 61 4_337.7	337.7	0.56	2.1	2.1	3.5	3.4	4.7	4.7	—	—	—	11.1
C 61 4_370.1	370.1	0.56	2.1	2.1	3.5	3.4	4.7	4.7	—	—	—	11.1
C 61 4_421.5	421.5	0.53	2.0	2.0	3.4	3.3	4.6	4.6	—	—	—	11.0
C 61 4_462.0	462.0	0.53	2.0	2.0	3.4	3.3	4.6	4.6	—	—	—	11.0
C 61 4_521.1	521.1	0.51	2.0	2.0	3.4	3.3	4.6	4.6	—	—	—	11.0
C 61 4_571.2	571.2	0.51	2.0	2.0	3.4	3.3	4.6	4.6	—	—	—	11.0
C 61 4_610.1	610.1	0.49	2.0	2.0	3.4	3.3	4.6	4.6	—	—	—	11.0
C 61 4_668.8	668.8	0.49	2.0	2.0	3.4	3.3	4.6	4.6	—	—	—	11.0
C 61 4_726.3	726.3	0.48	2.0	2.0	3.4	3.3	4.6	4.6	—	—	—	11.0
C 61 4_796.1	796.1	0.48	2.0	2.0	3.4	3.3	4.6	4.6	—	—	—	11.0

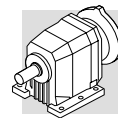

# C 70

	i	J ( $\cdot 10^{-4}$ ) [Kgm <sup>2</sup> ]													
			63	71	80	90	100 112	 IEC	132	160	180	200	225		250
C 70 2_4.6	4.6	—	—	—	—	—	—	—	136	133	143	—	—	—	99
C 70 2_5.9	5.9	—	—	—	—	—	—	—	119	117	126	—	—	—	32
C 70 2_6.3	6.3	—	—	—	—	—	—	—	129	127	136	—	—	—	93
C 70 2_7.5	7.5	26.4	—	—	—	—	—	45	105	102	112	—	—	—	68
C 70 2_8.0	8.0	—	—	—	—	—	—	—	115	113	122	—	—	—	78
C 70 2_9.5	9.5	18.7	—	—	—	—	—	38	97	95	—	—	—	—	60
C 70 2_10.2	10.2	23.8	—	—	—	—	—	43	102	100	109.0	—	—	—	65
C 70 2_11.2	11.2	15.3	—	—	—	—	—	34	94	91	—	—	—	—	56
C 70 2_13.0	13.0	17.2	—	—	—	—	—	36	95	93	—	—	—	—	58
C 70 2_14.1	14.1	9.9	—	—	12.3	12.2	13.5	28.9	88	86	—	—	—	—	51
C 70 2_15.3	15.3	14.2	—	—	—	—	—	33	93	90	—	—	—	—	55
C 70 2_16.7	16.7	6.9	—	—	9.5	9.4	10.7	25.9	85	83	—	—	—	—	48
C 70 2_19.3	19.3	9.1	—	—	11.6	11.5	12.8	28.0	87	85	—	—	—	—	50
C 70 2_22.9	22.9	6.4	—	—	9.0	8.9	10.2	25.3	85	83	—	—	—	—	48
C 70 2_27.7	27.7	5.2	—	—	8.0	7.9	9.2	24.1	84	81	—	—	—	—	46
C 70 2_34.7	34.7	3.2	—	—	6.1	6.0	7.3	22.1	82	79	—	—	—	—	44
C 70 3_41.3	41.3	4.4	—	—	7.2	7.2	8.5	23.3	83	80	—	—	—	—	46
C 70 3_44.7	44.7	4.2	—	—	7.0	7.0	8.2	23.0	83	80	—	—	—	—	45
C 70 3_52.2	52.2	3.0	—	—	5.8	5.8	7.0	21.9	81	79	—	—	—	—	44
C 70 3_56.5	56.5	2.8	—	—	5.7	5.6	6.9	21.7	81	79	—	—	—	—	44
C 70 3_65.9	65.9	2.0	—	—	4.9	4.8	6.1	20.9	80	78	—	—	—	—	43
C 70 3_71.3	71.3	2.0	—	—	4.8	4.8	6.0	20.9	80	78	—	—	—	—	43
C 70 3_81.4	81.4	1.5	—	—	4.3	4.3	5.6	20.4	80	78	—	—	—	—	43
C 70 3_88.2	88.2	1.4	—	—	4.3	4.2	5.5	20.3	80	76	—	—	—	—	43
C 70 3_103.8	103.8	1.0	—	—	3.8	3.8	5.1	19.9	79	77	—	—	—	—	42
C 70 3_112.4	112.4	0.9	—	—	3.8	3.7	5.0	19.8	79	77	—	—	—	—	42
C 70 3_126.8	126.8	0.7	—	—	3.5	3.5	4.8	19.6	79	77	—	—	—	—	42
C 70 3_137.4	137.4	0.7	—	—	3.5	3.5	4.7	19.6	79	77	—	—	—	—	42
C 70 3_150.3	150.3	0.5	—	—	3.4	3.4	9.6	—	—	—	—	—	—	—	42
C 70 3_162.8	162.8	0.5	—	—	3.4	3.4	4.6	—	—	—	—	—	—	—	42
C 70 3_179.2	179.2	0.4	—	—	3.2	3.3	4.5	—	—	—	—	—	—	—	42
C 70 3_194.1	194.1	0.4	—	—	3.2	3.2	4.5	—	—	—	—	—	—	—	42
C 70 3_220.9	220.9	0.3	—	—	3.1	3.1	4.3	—	—	—	—	—	—	—	41
C 70 3_239.3	239.3	0.3	—	—	3.1	3.1	4.3	—	—	—	—	—	—	—	41
C 70 4_251.3	251.3	0.7	2.2	2.2	3.5	3.5	4.8	19.6	79	77	—	—	—	—	10.9
C 70 4_272.2	272.2	0.7	2.2	2.1	3.5	3.5	4.8	19.6	79	77	—	—	—	—	10.9
C 70 4_317.9	317.9	0.5	2.0	2.0	3.4	3.3	4.6	19.4	79	77	—	—	—	—	10.7
C 70 4_344.3	344.3	0.5	2.0	2.0	3.4	3.3	4.6	19.4	79	77	—	—	—	—	10.7
C 70 4_409.4	409.4	0.4	1.8	1.8	3.2	3.2	4.5	19.3	79	76	—	—	—	—	7.9
C 70 4_443.5	443.5	0.4	1.8	1.8	3.2	3.2	4.5	19.3	79	76	—	—	—	—	7.9
C 70 4_512.0	512.0	0.3	1.7	1.7	3.1	3.1	4.4	19.2	79	76	—	—	—	—	7.8
C 70 4_554.7	554.7	0.3	1.7	1.7	3.1	3.1	4.4	19.2	79	76	—	—	—	—	7.8
C 70 4_606.8	606.8	0.2	1.7	1.7	3.1	3.0	4.3	—	—	—	—	—	—	—	7.8
C 70 4_657.3	657.3	0.2	1.7	1.7	3.1	3.0	4.3	—	—	—	—	—	—	—	7.7
C 70 4_736.0	736.0	0.2	1.6	1.6	3.0	2.9	4.3	—	—	—	—	—	—	—	7.7
C 70 4_797.3	797.3	0.2	1.6	1.6	3.0	2.9	4.3	—	—	—	—	—	—	—	7.7
C 70 4_922.6	922.6	0.1	1.6	1.6	3.0	2.9	4.2	—	—	—	—	—	—	—	7.7
C 70 4_999.5	999.5	0.1	1.6	1.6	3.0	2.9	4.2	—	—	—	—	—	—	—	7.6
C 70 4_1069	1069	0.8	1.6	1.5	2.9	2.9	4.2	—	—	—	—	—	—	—	7.6
C 70 4_1158	1158	0.8	1.6	1.5	2.9	2.9	4.2	—	—	—	—	—	—	—	7.6
C 70 4_1362	1362	0.6	1.5	1.5	2.9	2.9	4.1	—	—	—	—	—	—	—	7.6
C 70 4_1476	1476	0.6	1.5	1.5	2.9	2.9	4.1	—	—	—	—	—	—	—	7.6





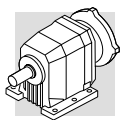

	i	J ( $\cdot 10^{-4}$ ) [Kgm <sup>2</sup> ]													
			63	71	80	90	100 112	132	160	180	200	225	250	280	
<b>C 80 2_5.6</b>	5.6	—	—	—	—	—	—	—	—	197	211	489	—	—	164
<b>C 80 2_6.1</b>	6.1	—	—	—	—	—	—	—	—	193	210	485	—	—	159
<b>C 80 2_7.0</b>	7.0	—	—	—	—	—	—	—	160	161	174	452	—	—	127
<b>C 80 2_7.6</b>	7.6	—	—	—	—	—	—	—	158	158	172	449	—	—	124
<b>C 80 2_8.9</b>	8.9	—	—	—	—	—	—	—	137	135	146	429	—	—	101
<b>C 80 2_9.6</b>	9.6	—	—	—	—	—	—	—	136	133	144	427	—	—	99
<b>C 80 2_11.1</b>	11.1	37.5	—	—	—	—	—	56	116	113	124	408	—	—	79
<b>C 80 2_12.0</b>	12.0	36.4	—	—	—	—	—	55	115	112	123	407	—	—	78
<b>C 80 2_13.8</b>	13.8	28.1	—	—	—	—	—	47	106	104	135	398	—	—	69
<b>C 80 2_14.9</b>	14.9	27.4	—	—	—	—	—	46	106	103	134	397	—	—	69
<b>C 80 2_16.7</b>	16.7	21.4	—	—	—	—	—	40	100	97	127	391	—	—	63
<b>C 80 2_18.1</b>	18.1	20.9	—	—	—	—	—	40	99	97	127	390	—	—	62
<b>C 80 2_20.5</b>	20.5	14.2	—	—	16.6	16.6	17.9	33	93	90	120	383	—	—	55
<b>C 80 2_22.2</b>	22.2	13.9	—	—	16.3	16.3	17.6	33	92	90	120	383	—	—	55
<b>C 80 2_24.0</b>	24.0	13.1	—	—	15.7	15.6	16.9	32	91	89	119	382	—	—	54
<b>C 80 2_25.9</b>	25.9	12.9	—	—	15.5	15.4	16.7	32	91	89	118	382	—	—	54
<b>C 80 2_31.3</b>	31.3	8.7	—	—	11.5	11.4	12.7	27.6	87	85	—	—	—	—	50
<b>C 80 2_39.1</b>	39.1	5.2	—	—	8.0	8.0	9.2	24.1	84	81	—	—	—	—	46
<b>C 80 3_43.5</b>	43.5	9.6	—	—	12.4	12.4	13.7	29	88	86	—	—	—	—	51
<b>C 80 3_47.4</b>	47.4	9.1	—	—	12.0	11.9	13.2	28	87	85	—	—	—	—	50
<b>C 80 3_57.3</b>	57.3	5.7	—	—	8.5	8.5	9.7	25	84	82	—	—	—	—	47
<b>C 80 3_62.5</b>	62.5	5.4	—	—	8.2	8.2	9.5	24	84	82	—	—	—	—	47
<b>C 80 3_70.5</b>	70.5	4.3	—	—	7.1	7.0	8.3	23	83	80	—	—	—	—	45
<b>C 80 3_76.9</b>	76.9	4.1	—	—	7.0	6.9	8.2	23	82	80	—	—	—	—	45
<b>C 80 3_89.3</b>	89.3	3.0	—	—	5.9	5.8	7.1	22	81	79	—	—	—	—	44
<b>C 80 3_97.4</b>	97.4	2.9	—	—	5.8	5.7	7.0	22	81	79	—	—	—	—	44
<b>C 80 3_109.5</b>	109.5	2.0	—	—	4.8	4.8	6.1	21	80	78	—	—	—	—	43
<b>C 80 3_119.5</b>	119.5	1.9	—	—	4.8	4.7	6.0	21	80	79	—	—	—	—	43
<b>C 80 3_136.7</b>	136.7	1.4	—	—	4.3	4.2	5.5	20	80	78	—	—	—	—	43
<b>C 80 3_149.1</b>	149.1	1.4	—	—	4.2	4.2	5.5	20	80	77	—	—	—	—	43
<b>C 80 3_169.0</b>	169.0	1.0	—	—	3.9	3.8	5.1	—	—	—	—	—	—	—	42
<b>C 80 3_184.4</b>	184.4	1.0	—	—	3.9	3.8	5.1	—	—	—	—	—	—	—	42
<b>C 80 3_197.9</b>	197.9	0.8	—	—	3.7	3.6	4.9	—	—	—	—	—	—	—	42
<b>C 80 3_215.8</b>	215.8	0.8	—	—	3.6	3.6	4.9	—	—	—	—	—	—	—	42
<b>C 80 4_261.9</b>	261.9	1.7	—	—	4.6	4.5	5.8	20.6	80	78	—	—	—	—	11.9
<b>C 80 4_285.7</b>	285.7	1.7	—	—	4.6	4.5	5.8	20.6	80	78	—	—	—	—	11.9
<b>C 80 4_334.3</b>	334.3	1.2	2.7	2.7	4.0	4.0	5.3	20.1	80	77	—	—	—	—	11.4
<b>C 80 4_364.7</b>	364.7	1.2	2.7	2.6	4.0	4.0	5.3	20.1	80	77	—	—	—	—	11.4
<b>C 80 4_417.5</b>	417.5	0.9	2.4	2.3	3.7	3.7	5.0	19.8	79	77	—	—	—	—	11.1
<b>C 80 4_455.4</b>	455.4	0.9	2.3	2.3	3.7	3.7	5.5	19.8	79	77	—	—	—	—	11.1
<b>C 80 4_529.3</b>	529.3	0.5	2.0	2	3.4	3.3	4.6	19.4	79	77	—	—	—	—	10.7
<b>C 80 4_577.4</b>	577.4	0.5	2.0	2	3.4	3.3	4.6	19.4	79	77	—	—	—	—	10.7
<b>C 80 4_664.3</b>	664.3	0.4	2.0	1.9	3.3	3.2	4.5	19.3	78	77	—	—	—	—	10.6
<b>C 80 4_724.7</b>	724.7	0.4	2.0	1.9	3.3	3.2	4.5	19.3	78	77	—	—	—	—	10.6
<b>C 80 4_783.4</b>	783.4	0.3	2.0	1.8	3.2	3.1	4.4	—	—	—	—	—	—	—	9.4
<b>C 80 4_854.6</b>	854.6	0.3	2.0	1.8	3.2	3.1	4.4	—	—	—	—	—	—	—	9.4
<b>C 80 4_945.7</b>	945.7	0.2	1.7	1.7	3.1	3.0	4.3	—	—	—	—	—	—	—	9.3
<b>C 80 4_1032</b>	1032	0.2	1.7	1.7	3.1	3.0	4.3	—	—	—	—	—	—	—	9.3
<b>C 80 4_1168</b>	1168	0.2	1.6	1.6	3.0	3.0	4.2	—	—	—	—	—	—	—	9.2
<b>C 80 4_1274</b>	1274	0.2	1.6	1.6	3.0	3.0	4.2	—	—	—	—	—	—	—	9.2
<b>C 80 4_1358</b>	1358	0.1	1.6	1.6	3	2.9	4.2	—	—	—	—	—	—	—	9.2
<b>C 80 4_1481</b>	1481	0.1	1.6	1.6	3	2.9	4.2	—	—	—	—	—	—	—	9.2

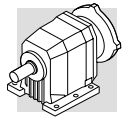

# C 90

	i	J ( $\cdot 10^{-4}$ ) [Kgm <sup>2</sup> ]													
			63	71	80	90	100 112	132	160	180	200	225	250		280
C 90 2_5.2	5.2	—	—	—	—	—	—	—	—	—	332	610	637	—	619
C 90 2_5.6	5.6	—	—	—	—	—	—	—	—	—	321	599	626	—	609
C 90 2_6.8	6.8	—	—	—	—	—	—	—	—	—	252	530	557	—	540
C 90 2_7.3	7.3	—	—	—	—	—	—	—	—	—	246	524	551	—	533
C 90 2_8.3	8.3	—	—	—	—	—	—	—	—	—	212	490	517	—	499
C 90 2_9.0	9.0	—	—	—	—	—	—	—	—	—	208	485	513	—	495
C 90 2_10.4	10.4	—	—	—	—	—	—	167	164	175	458	484	—	461	
C 90 2_11.2	11.2	—	—	—	—	—	—	164	162	173	455	482	—	458	
C 90 2_12.8	12.8	64.9	—	—	—	—	84	143	141	152	436	462	—	439	
C 90 2_13.9	13.9	63.2	—	—	—	—	82	141	139	200	434	460	—	437	
C 90 2_16.0	16.0	47.0	—	—	—	—	66	125	123	154	417	443	—	420	
C 90 2_17.3	17.3	45.9	—	—	—	—	65	124	122	153	416	442	—	419	
C 90 2_18.7	18.7	42.4	—	—	—	—	61	121	119	148	412	433	—	415	
C 90 2_20.2	20.2	41.4	—	—	—	—	61	199	118	147	411	438	—	414	
C 90 2_22.9	22.9	27.6	—	—	30	30	31	47	106	104	133	397	423	—	400
C 90 2_24.8	24.8	27.0	—	—	29.4	29.4	31	46	105	103	133	396	422	—	399
C 90 2_27.2	27.2	22.1	—	—	24.9	24.8	26.1	41	101	99	128	391	418	—	394
C 90 2_29.4	29.4	21.9	—	—	24.5	24.4	25.7	41	100	98	127	391	417	—	394
C 90 2_35.1	35.1	14.0	—	—	16.8	16.7	18.0	33	93	90	—	—	—	—	386
C 90 3_39.4	39.4	27.2	—	—	—	—	—	46	105	103	112	398	—	—	412
C 90 3_43.0	43.0	26.1	—	—	—	—	—	45	104	102	111	396	—	—	410
C 90 3_50.3	50.3	19.3	—	—	—	—	—	38	98	95	126	389	—	—	403
C 90 3_54.9	54.9	18.5	—	—	—	—	—	37	97	95	125	389	—	—	401
C 90 3_59.2	59.2	15.7	—	—	—	—	—	35	94	92	122	385	—	—	398
C 90 3_64.6	64.6	15.2	—	—	—	—	—	34	94	91	121	384	—	—	398
C 90 3_74.4	74.4	10.1	—	—	12.5	12.5	13.8	29.0	88	86	116	379	—	—	393
C 90 3_81.2	81.2	9.8	—	—	12.2	12.1	13.4	28.7	88	86	115	379	—	—	392
C 90 3_88.2	88.2	7.1	—	—	9.7	9.6	10.9	26.0	85	83	113	376	—	—	389
C 90 3_96.2	96.2	6.9	—	—	9.4	9.4	10.7	25.8	85	83	112	376	—	—	389
C 90 3_107.0	107.0	5.7	—	—	8.4	8.4	9.6	24.6	84	82	—	—	—	—	388
C 90 3_116.7	116.7	5.5	—	—	8.3	8.2	9.5	24.4	84	82	—	—	—	—	388
C 90 3_134.1	134.1	3.5	—	—	6.4	6.3	7.6	22.4	82	80	—	—	—	—	386
C 90 3_146.3	146.3	3.4	—	—	6.3	6.2	7.5	22.3	82	80	—	—	—	—	386
C 90 3_157.8	157.8	2.5	—	—	5.4	5.3	6.6	21.4	81	79	—	—	—	—	385
C 90 3_172.1	172.1	2.4	—	—	5.3	5.2	6.5	21.3	81	79	—	—	—	—	385
C 90 4_212.4	212.4	4.2	—	—	7.0	7.0	8.3	23.1	82.5	80.2	—	—	—	—	14.4
C 90 4_231.7	231.7	4.1	—	—	7.0	6.9	8.2	23.0	82.4	80.2	—	—	—	—	14.3
C 90 4_268.5	268.5	2.8	—	—	5.7	5.6	6.9	21.7	81.1	78.9	—	—	—	—	13
C 90 4_292.9	292.9	2.8	—	—	5.7	2.6	6.9	21.7	81.1	78.9	—	—	—	—	13
C 90 4_339.0	339.0	2.0	3.4	3.4	4.8	4.8	6.0	20.9	80.3	78.0	—	—	—	—	12.2
C 90 4_369.8	369.8	2.0	3.4	3.4	4.8	4.8	6.0	20.9	80.2	78.0	—	—	—	—	12.2
C 90 4_419.0	419.0	1.4	2.9	2.9	4.3	4.2	5.5	20.3	79.7	77.5	—	—	—	—	11.6
C 90 4_457.1	457.1	1.4	2.9	2.9	4.3	4.2	5.5	20.3	79.7	77.5	—	—	—	—	11.6
C 90 4_534.2	534.2	0.9	2.4	2.4	3.8	3.7	5.0	19.8	79.2	77.0	—	—	—	—	11.1
C 90 4_582.8	582.8	0.9	2.4	2.4	3.8	3.7	5.0	19.8	79.2	77.0	—	—	—	—	11.1
C 90 4_652.8	652.8	0.7	2.1	2.1	3.5	3.5	4.7	19.6	79.0	76.7	—	—	—	—	10.9
C 90 4_712.2	712.2	0.7	2.1	2.1	3.5	3.5	4.7	19.6	79.0	76.7	—	—	—	—	10.9
C 90 4_773.6	773.6	0.5	2	2	3.4	3.3	4.6	—	—	—	—	—	—	—	9.7
C 90 4_844.0	844.0	0.5	2	2	3.4	3.3	4.6	—	—	—	—	—	—	—	9.6
C 90 4_922.3	922.3	0.4	1.8	1.8	3.2	3.2	4.5	—	—	—	—	—	—	—	9.5
C 90 4_1006	1006	0.4	1.8	1.8	3.2	3.2	4.5	—	—	—	—	—	—	—	9.4
C 90 4_1137	1137	0.3	1.7	1.7	3.1	3.0	4.3	—	—	—	—	—	—	—	9.3
C 90 4_1240	1240	0.3	1.7	1.7	3.1	3.0	4.3	—	—	—	—	—	—	—	9.3



	i	J ( $\cdot 10^{-4}$ ) [Kgm <sup>2</sup> ]												
			IEC 											
		63	71	80	90	100 112	132	160	180	200	225	250	280	
C 100 2_4.9	4.9	—	—	—	—	—	—	—	—	674	960	987	970	972
C 100 2_5.3	5.3	—	—	—	—	—	—	—	—	647	933	960	943	944
C 100 2_6.5	6.5	—	—	—	—	—	—	—	—	481	767	794	777	778
C 100 2_7.1	7.1	—	—	—	—	—	—	—	—	465	751	778	761	763
C 100 2_8.4	8.4	—	—	—	—	—	—	—	—	365	651	678	660	662
C 100 2_9.0	9.0	—	—	—	—	—	—	—	—	355	641	668	651	653
C 100 2_10.1	10.1	—	—	—	—	—	—	—	—	291	577	604	587	589
C 100 2_10.9	10.9	—	—	—	—	—	—	—	—	285	570	597	580	582
C 100 2_12.5	12.5	—	—	—	—	—	—	224	222	233	521	550	539	529
C 100 2_13.5	13.5	—	—	—	—	—	—	220	218	228	517	545	532	524
C 100 2_15.2	15.2	122.1	—	—	—	—	—	141	200	199	209	499	528	514
C 100 2_16.5	16.5	119.2	—	—	—	—	138	197	195	206	296	525	511	504
C 100 2_18.7	18.7	96.6	—	—	—	—	116	175	173	203	474	501	488	480
C 100 2_20.2	20.2	94.7	—	—	—	—	114	173	171	201	471	499	486	478
C 100 2_22.2	22.2	73.4	—	—	—	—	92	102	150	179	448	477	463	456
C 100 2_24.1	24.1	72.1	—	—	—	—	91	150	148	178	447	476	462	455
C 100 2_29.6	29.6	50.4	—	—	—	54.1	69	129	127	156	425	454	440	433
C 100 3_34.3	34.3	—	—	—	—	—	—	148	146	155	439	—	—	461
C 100 3_36.9	36.9	—	—	—	—	—	—	145	143	152	436	—	—	458
C 100 3_42.9	42.9	44.4	—	—	—	—	63	123	120	130	415	—	—	437
C 100 3_46.2	46.2	42.5	—	—	—	—	61	121	118	128	413	—	—	435
C 100 3_53.3	53.3	32.5	—	—	—	—	51	111	109	139	403	—	—	424
C 100 3_57.4	57.4	31.4	—	—	—	—	50	110	107	138	401	—	—	423
C 100 3_64.5	64.5	24.4	—	—	—	—	43	103	101	130	394	—	—	415
C 100 3_69.4	69.4	23.6	—	—	—	—	43	102	100	129	393	—	—	414
C 100 3_79.4	79.4	16.2	—	—	18.6	18.6	19.9	35	95	92	122	385	—	407
C 100 3_85.6	85.6	15.7	—	—	18.1	18.0	19.3	35	94	92	121	385	—	406
C 100 3_92.7	92.7	14.6	—	—	17.2	17.1	18.4	34	93	91	—	—	—	405
C 100 3_99.8	99.8	14.2	—	—	16.8	16.7	18.0	33	93	901	—	—	—	404
C 100 3_111.9	111.9	9.9	—	—	12.6	12.6	13.9	28.8	88	86	—	—	—	392
C 100 3_120.5	120.5	9.6	—	—	12.4	12.3	13.6	28.5	88	86	—	—	—	392
C 100 3_139.7	139.7	6.0	—	—	8.8	8.7	10.0	24.8	84	82	—	—	—	388
C 100 3_150.4	150.4	5.8	—	—	8.6	8.5	9.8	24.7	84	82	—	—	—	388
C 100 4_162.1	162.1	12.7	—	—	15.6	15.5	16.8	32	100	89	—	—	—	22.9
C 100 4_185.4	185.4	9.6	—	—	12.5	12.4	13.8	28.5	88	86	—	—	—	19.8
C 100 4_199.6	199.6	8.5	—	—	12.4	12.3	13.7	28.4	88	86	—	—	—	19.7
C 100 4_244.2	244.2	5.7	—	—	8.5	8.5	9.8	24.6	84	82	—	—	—	15.9
C 100 4_263.0	263.0	5.6	—	—	8.5	8.4	9.7	24.5	84	82	—	—	—	15.8
C 100 4_300.5	300.5	4.2	—	—	7.1	7.1	8.4	23.2	83	80	—	—	—	14.5
C 100 4_323.6	323.6	4.2	5.7	5.7	7.1	7.0	8.3	23.1	83	80	—	—	—	14.4
C 100 4_380.5	380.5	3.1	4.5	4.5	5.9	5.5	7.1	22	81	79	—	—	—	13.3
C 100 4_409.8	409.8	3.0	4.5	4.5	5.9	5.5	7.1	22	81	79	—	—	—	13.2
C 100 4_466.7	466.7	2.0	3.5	3.5	4.9	4.8	6.1	20.1	80	78	—	—	—	12.2
C 100 4_502.6	502.6	2.0	3.5	3.4	4.8	4.8	6.1	20.1	80	78	—	—	—	12.2
C 100 4_582.6	582.6	1.4	2.9	2.9	4.3	4.2	5.5	20.3	80	77	—	—	—	11.6
C 100 4_627.4	627.4	1.4	2.9	2.9	4.3	4.2	5.5	20.3	80	77	—	—	—	11.6
C 100 4_720.3	720.3	1.0	2.5	2.5	3.9	3.4	5.1	20	79	77	—	—	—	11.2
C 100 4_775.7	775.7	1.0	2.5	2.5	3.9	3.4	5.1	20	79	77	—	—	—	11.2
C 100 4_843.3	843.3	0.8	2.3	2.3	3.7	3.6	4.9	—	—	—	—	—	—	9.9
C 100 4_908.2	908.2	0.8	2.3	2.3	3.7	3.6	4.9	—	—	—	—	—	—	9.9
C 100 4_1004	1004	0.6	2.1	2.0	3.4	3.4	4.7	—	—	—	—	—	—	9.7
C 100 4_1081	1081	0.6	2.1	2.0	3.4	3.4	4.7	—	—	—	—	—	—	9.7

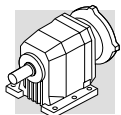

# C 05...M

28 - DIMENSIONI

28 - DIMENSIONS

28 - ABMESSUNGEN

28 - DIMENSIONS

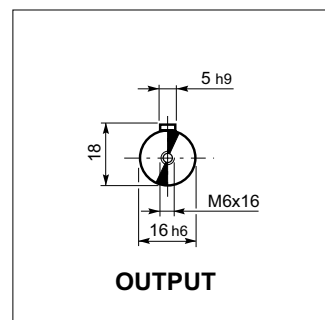
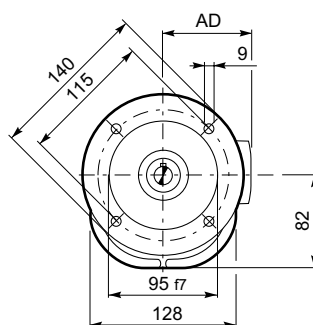
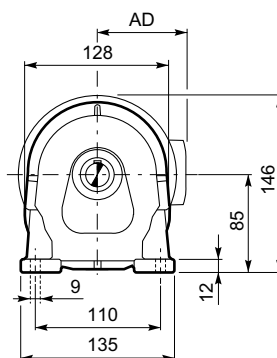
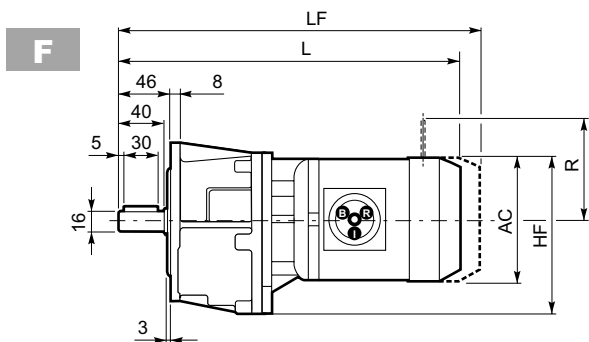
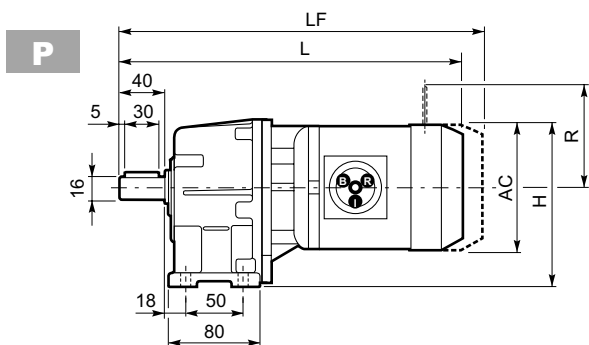

C 05															
									M...FD M...FA		M...FD		M...FA		
			AC	H	HF	L	AD		LF		R	AD	R	AD	
C 05 2	S0	M0	110	140	137	287	91	7	—	—	—	—	—	—	
C 05 2	S05	M05	121	145.5	142.5	332	95	8	398	10	96	119	116	95	
C 05 2	S1	M1S	138	154	151	337	108	9	400	12	103	132	124	108	
C 05 2	S1	M1L	138	154	151	360.5	108	11	423	13	103	132	124	108	

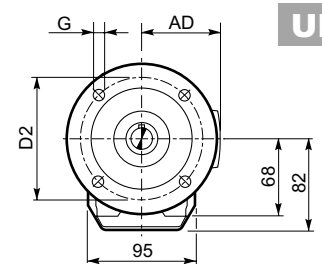
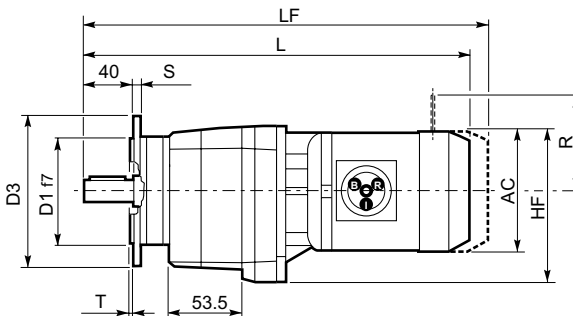
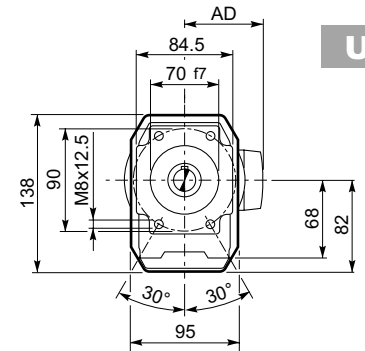
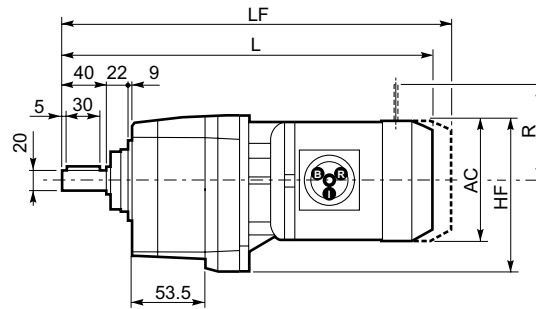
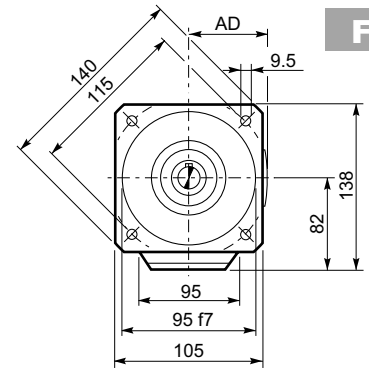
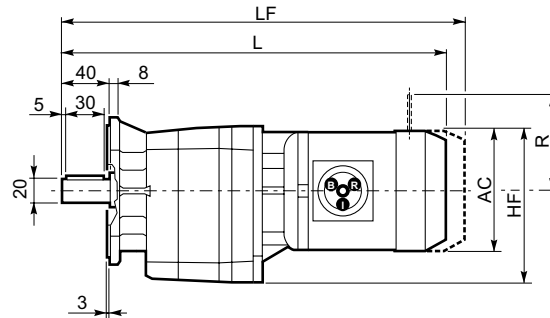
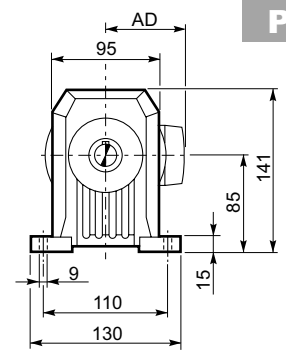
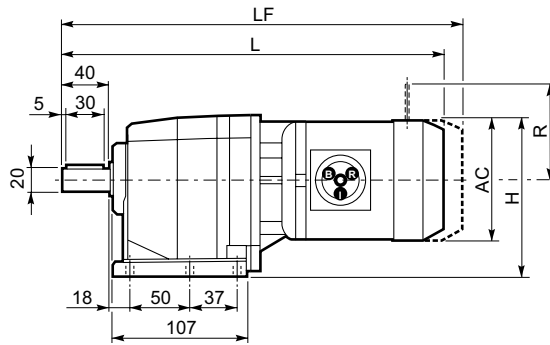
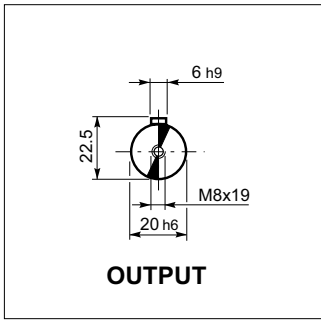
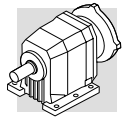

C 11 2 U						
	D1	D2	D3	G	T	S
FA	80	100	120	7	3	8
FB	95	115	140	9	3	10
FC	110	130	160	9	3	10

C 11															
Motor Type	S	M	Dimensions (mm)							M...FD / M...FA		M...FD		M...FA	
			AC	H	HF	L	AD	kg	LF	kg	R	AD	R	AD	
C 11 2	S05	M05	121	145.5	142.5	370.5	95	9	436.5	10	96	119	116	95	
C 11 2	S1	M1S	138	154	151	375.5	108	10	438.5	12	103	132	124	108	
C 11 2	S1	M1L	138	154	151	404.5	108	11	460.5	13	103	132	124	108	
C 11 2	S2	M2S	156	163	160	422.5	119	15	498.5	18	129	143	134	119	
C 11 2	S3	M3S	195	182.5	179.5	471.5	142	20	567.5	25	160	155	160	142	
C 11 2	S3	M3L	195	182.5	179.5	503.5	142	22	594.5	27	160	155	160	142	



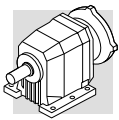

# C 11...P(IEC)

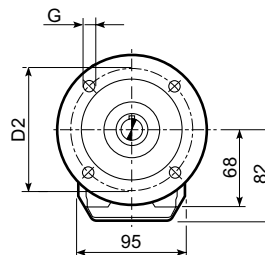
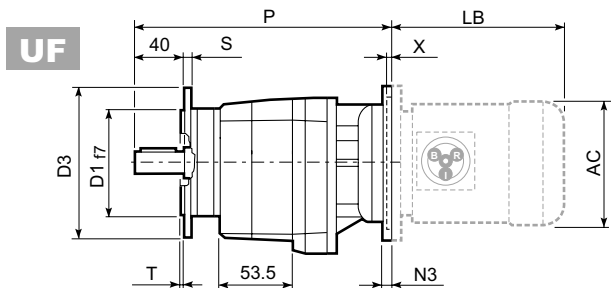
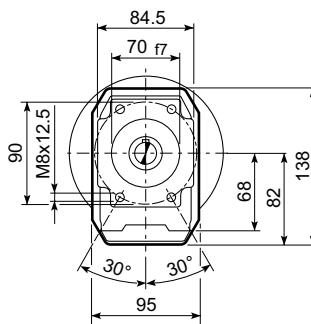
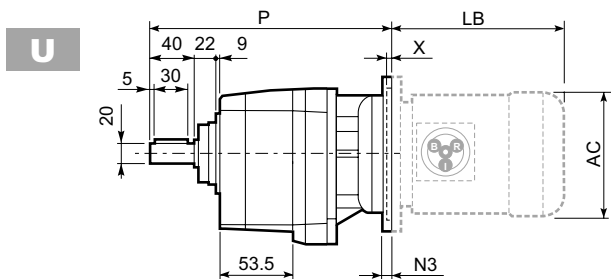
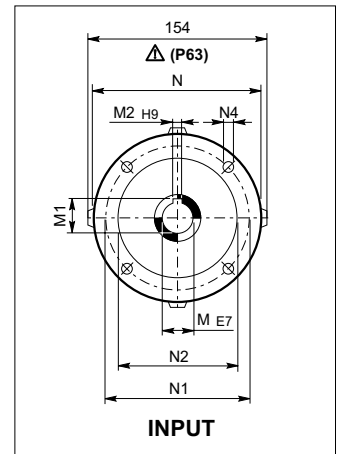
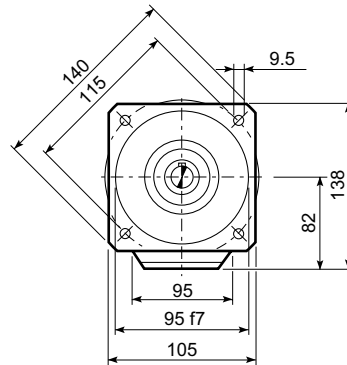
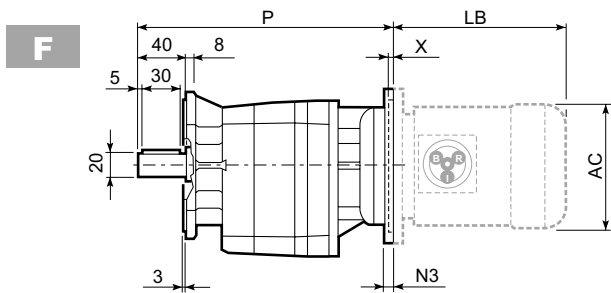
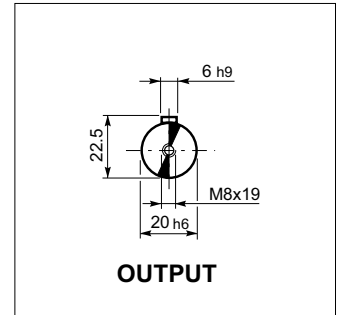
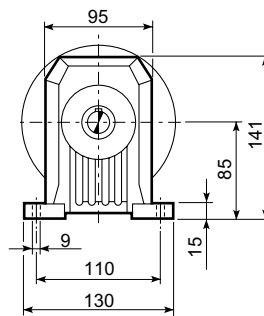
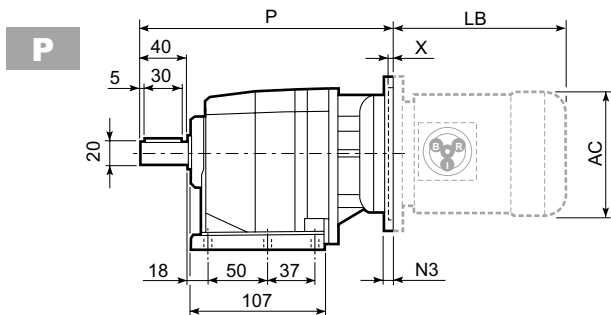

**C 11 2 U**

	D1	D2	D3	G	T	S
FA	80	100	120	7	3	8
FB	95	115	140	9	3	10
FC	110	130	160	9	3	10

C 11													BN...		BN...FD BN...FA			
		M	M1	M2	N	N1	N2	N3	N4	X	P			LB	AC	LB	AC	
C 11 2	P63	11	12.8	4	140	115	95	—	M8x19	4	244.5	6		BN 63	184	121	249	121
C 11 2	P71	14	16.3	5	160	130	110	—	M8x16	4,5	244.5	6		BN 71	219	138	280	138
C 11 2	P80	19	21.8	6	200	165	130	—	M10x12	4	264	7		BN 80	234	156	306	156
C 11 2	P90	24	27.3	8	200	165	130	—	M10x12	4	264	7		BN 90	276	176	359	176
C 11 2	P100	28	31.3	8	250	215	180	—	M12x16	4,5	274	11		BN 100	307	195	398	195
C 11 2	P112	28	31.3	8	250	215	180	—	M12x16	4,5	274	11		BN 112	325	219	424	219

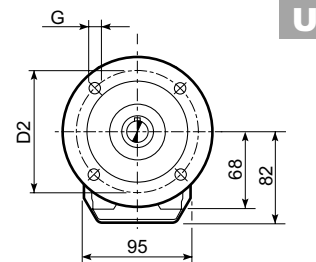
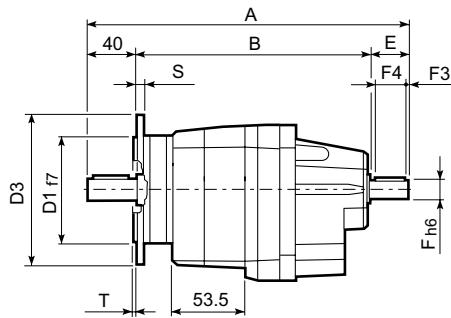
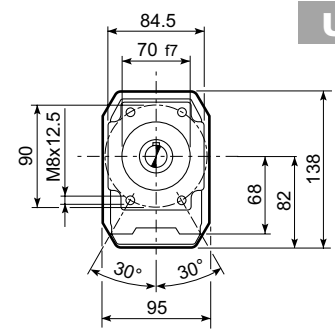
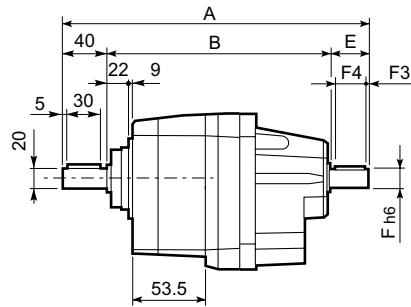
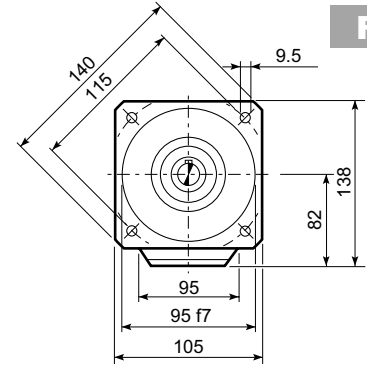
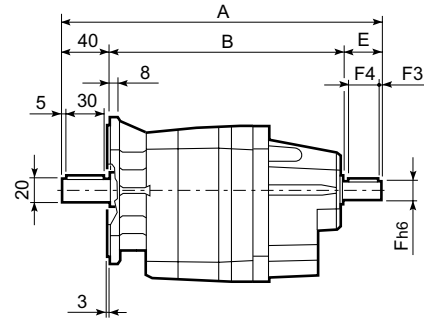
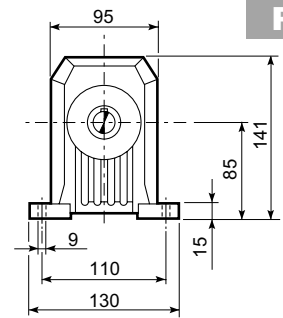
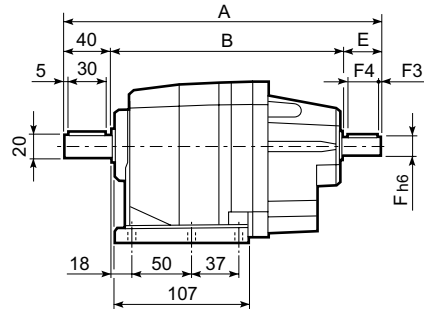
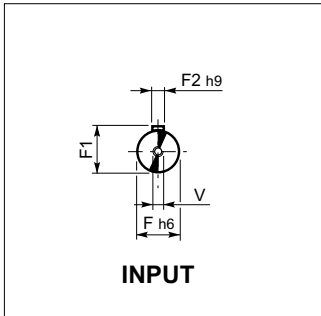
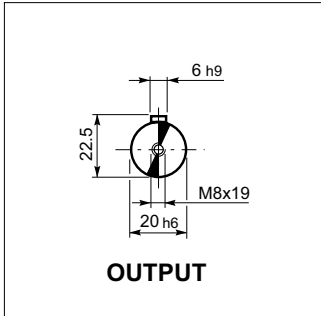
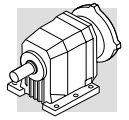

C 11 2 U						
	D1	D2	D3	G	T	S
FA	80	100	120	7	3	8
FB	95	115	140	9	3	10
FC	110	130	160	9	3	10

C 11													
		A	B	E	F	F1	F2	F3	F4	V	kg		
		C 11 2	HS	251.5	171.5	40	16	18	5	2.5	35	M6x16	7.8

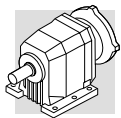

# C 21...M

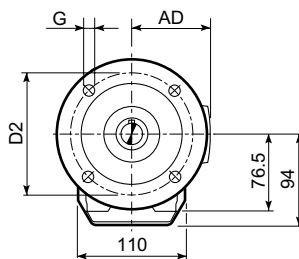
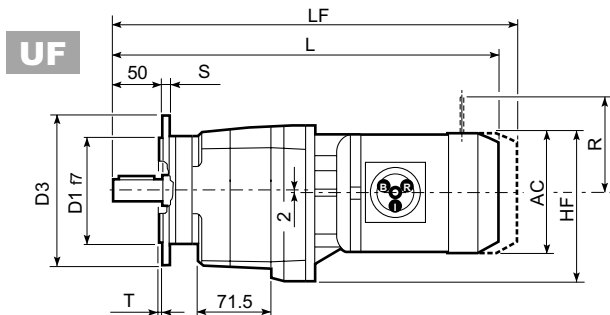
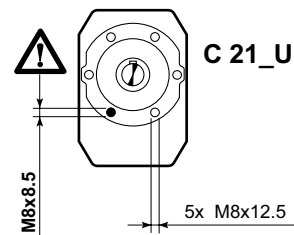
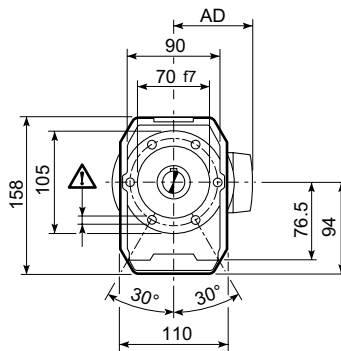
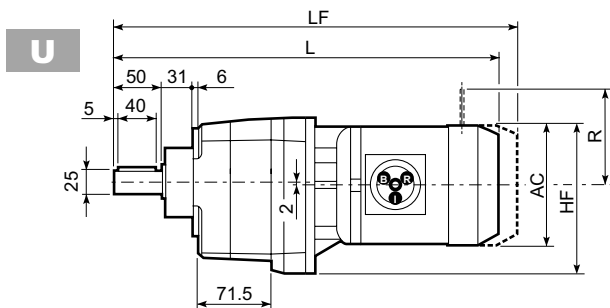
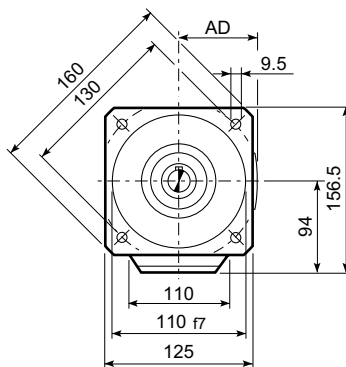
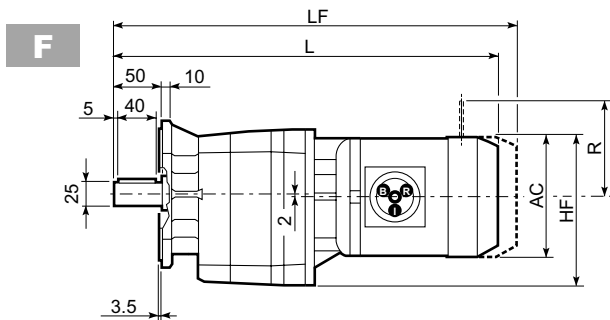
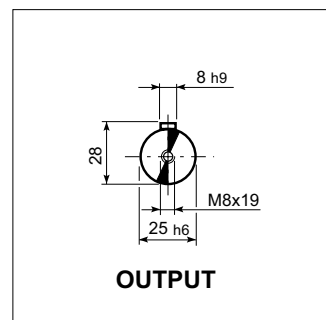
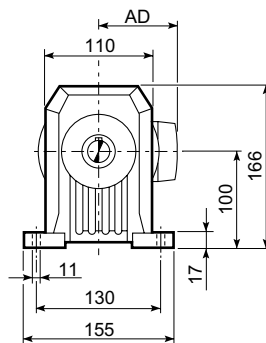
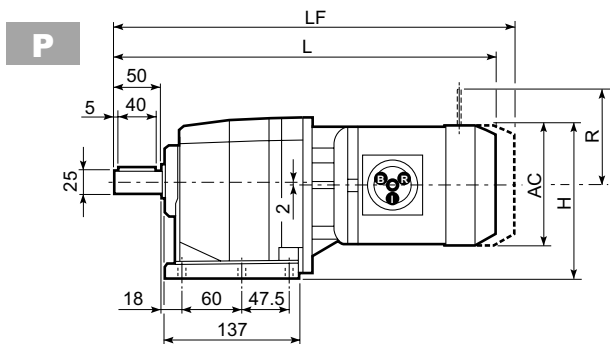

C 21_U						
	D1	D2	D3	G	T	S
FA	95	115	140	9	3	10
FB	110	130	160	9	3	10
FC	130	165	200	11	3.5	11

C 21														
			M...FD M...FA							M...FD		M...FA		
			AC	H	HF	L	AD	Kg	LF	Kg	R	AD	R	AD
C 21 2	S1	M1S	138	169	163	404	108	10	467	13	103	132	124	108
C 21 2	S1	M1L	138	169	163	428	108	11	489	14	103	132	124	108
C 21 2	S2	M2S	156	178	170	456	119	16	527	19	129	143	134	119
C 21 2	S3	M3S	195	197.5	191.5	500	142	21	596	26	160	155	160	142
C 21 2	S3	M3L	195	197.5	191.5	532	142	27	623	32	160	155	160	142
C 21 3	S05	M05	121	160.5	154.5	454.5	95	11	520.5	12	96	119	116	95
C 21 3	S1	M1S	138	169	163	459.5	108	12	522.5	14	103	132	124	108
C 21 3	S1	M1L	138	169	163	483.5	108	13	544.5	15	103	132	124	108

# C 21...P(IEC)

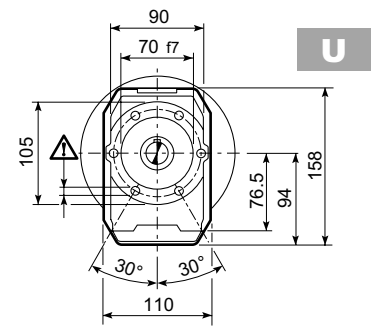
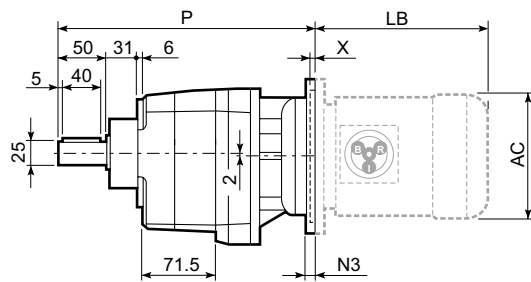
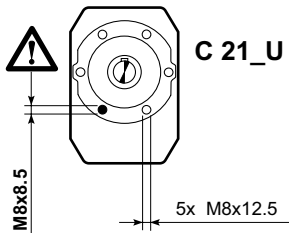
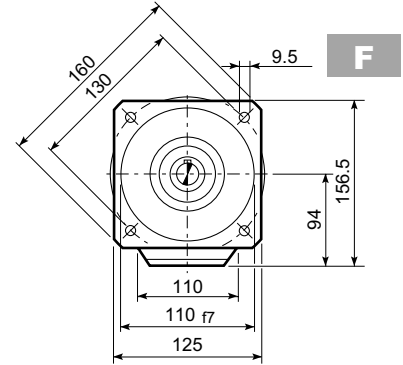
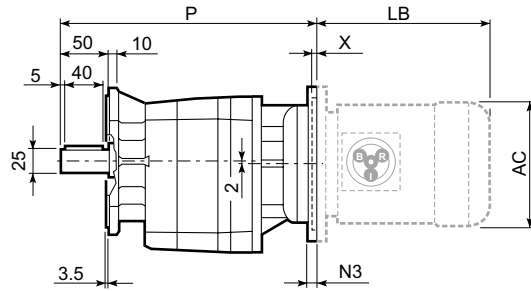
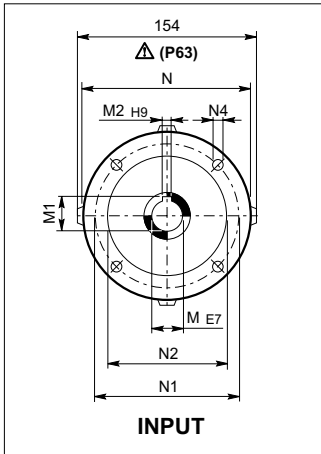
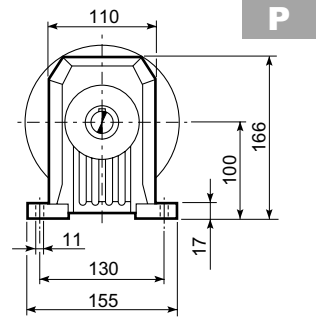
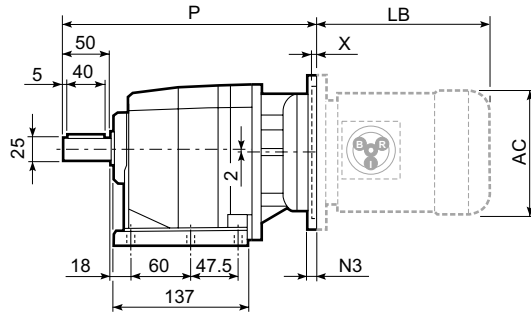
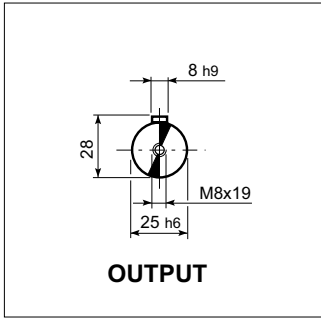
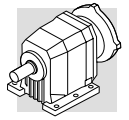

C 21_U						
	D1	D2	D3	G	T	S
FA	95	115	140	9	3	10
FB	110	130	160	9	3	10
FC	130	165	200	11	3.5	11

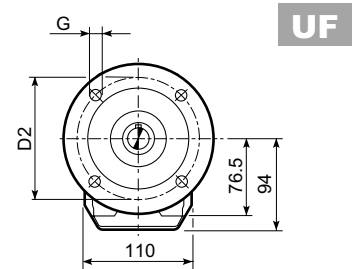
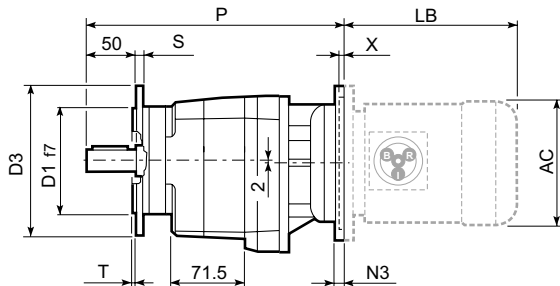

C 21													BN...		BN...FD BN...FA			
		M	M1	M2	N	N1	N2	N3	N4	X	P		LB	AC	LB	AC		
	<b>C 21 2</b>	<b>P63</b>	11	12.8	4	140	115	95	—	M8x19	4	273	7	BN 63	184	121	249	121
	<b>C 21 2</b>	<b>P71</b>	14	16.3	5	160	130	110	—	M8x16	4.5	273	7	BN 71	219	138	280	138
	<b>C 21 2</b>	<b>P80</b>	19	21.8	6	200	165	130	—	M10x12	4	292.5	8	BN 80	234	156	306	156
	<b>C 21 2</b>	<b>P90</b>	24	27.3	8	200	165	130	—	M10x12	4	292.5	8	BN 90	276	176	359	176
	<b>C 21 2</b>	<b>P100</b>	28	31.3	8	250	215	180	—	M12x16	4.5	302.5	12	BN 100	307	195	398	195
	<b>C 21 2</b>	<b>P112</b>	28	31.3	8	250	215	180	—	M12x16	4.5	302.5	12	BN 112	325	219	424	219
	<b>C 21 3</b>	<b>P63</b>	11	12.8	4	140	115	95	—	M8x19	4	328.5	8	BN 63	184	121	249	121
	<b>C 21 3</b>	<b>P71</b>	14	16.3	5	160	130	110	—	M8x16	4.5	328.5	8	BN 71	219	138	280	138
	<b>C 21 3</b>	<b>P80</b>	19	21.8	6	200	165	130	—	M10x12	4	348	9	BN 80	234	156	306	156
	<b>C 21 3</b>	<b>P90</b>	24	27.3	8	200	165	130	—	M10x12	4	348	9	BN 90	276	176	359	176
	<b>C 21 3</b>	<b>P100</b>	28	31.3	8	250	215	180	—	M12x16	4.5	358	13	BN 100	307	195	398	195
	<b>C 21 3</b>	<b>P112</b>	28	31.3	8	250	215	180	—	M12x16	4.5	358	13	BN 112	325	219	424	219

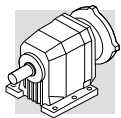

# C 21...HS

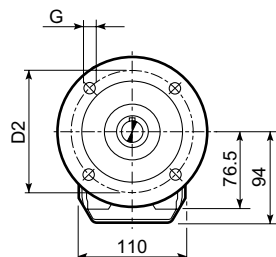
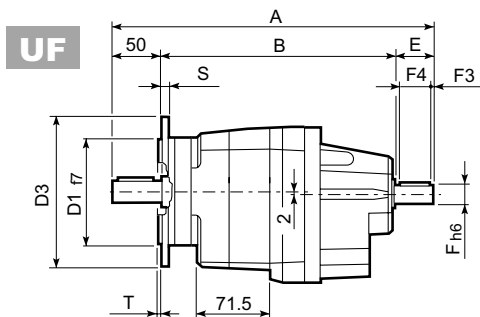
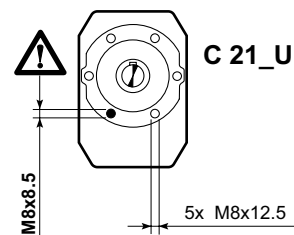
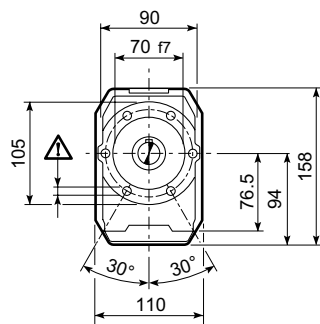
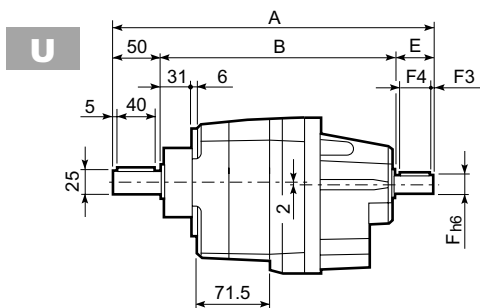
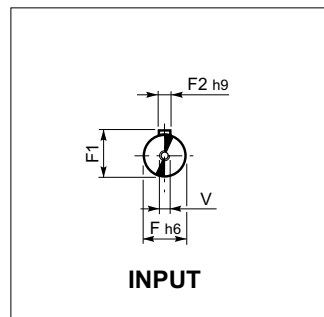
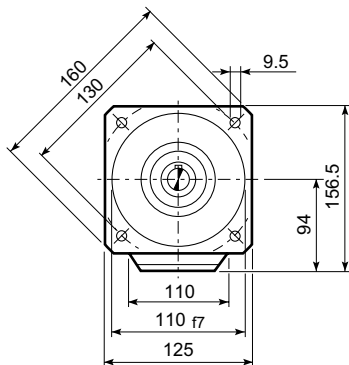
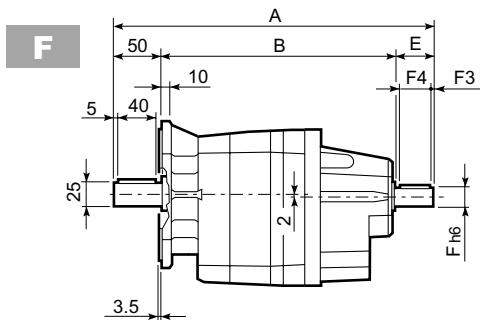
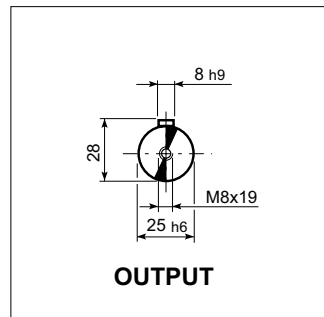
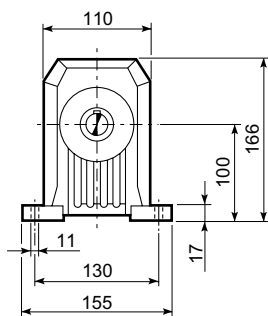
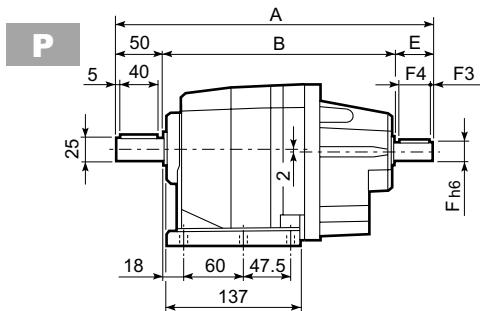

C 21_U						
	D1	D2	D3	G	T	S
FA	95	115	140	9	3	10
FB	110	130	160	9	3	10
FC	130	165	200	11	3.5	11

C 21											
		A	B	E	F	F1	F2	F3	F4	V	Kg
	HS	323	233	40	19	21.5	6	2.5	35	M6x16	7.2
		335.5	245.5	40	16	18	6	2.5	36	M6x16	7.5

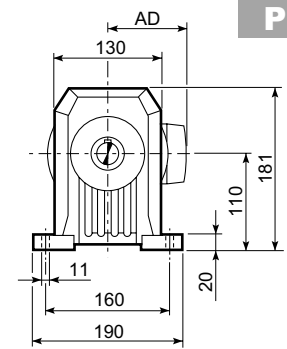
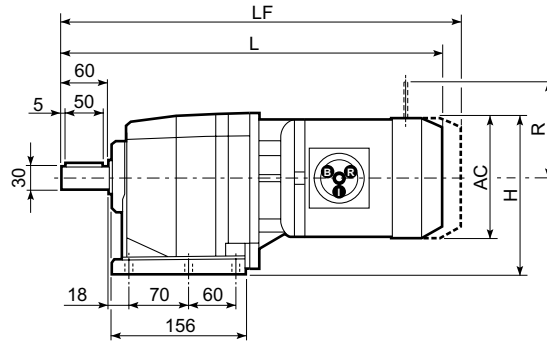
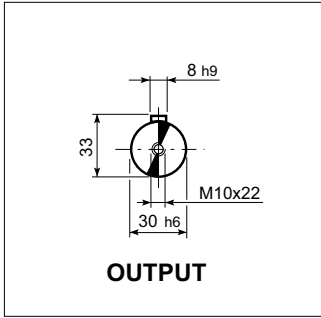
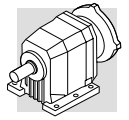

**P**

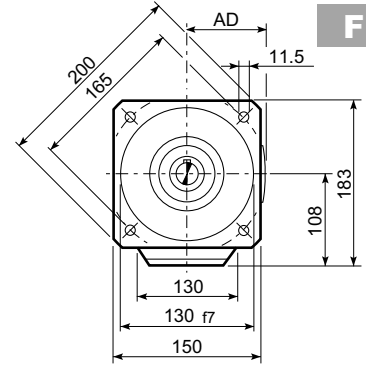
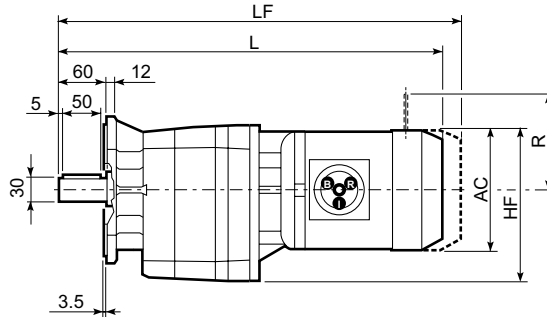

**F**

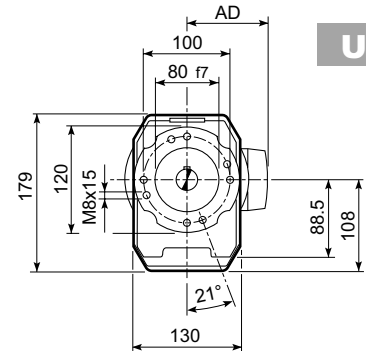
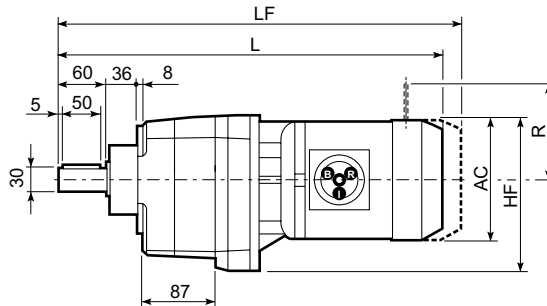

**U**

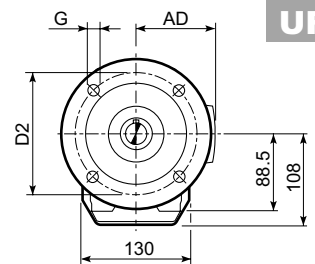
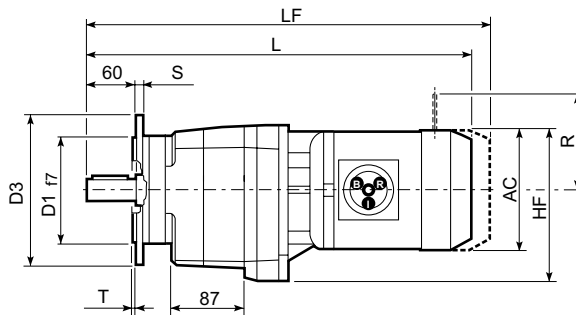

**UF**

C 31 U						
	D1	D2	D3	G	T	S
FA	110	130	160	9	3	10
FB	130	165	200	11	3.5	11
FC	180	215	250	14	4	13

## C 31

Motor Type	Frame	Mounting	AC	H	HF	L	AD	Kg	M...FD M...FA		M...FD		M...FA	
									LF	Kg	R	AD	R	AD
C 31 2	S1	M1S	138	179	177	438.5	108	13	501.5	15	103	132	124	108
C 31 2	S1	M1L	138	179	177	462.5	108	14	523.5	16	103	132	124	108
C 31 2	S2	M2S	156	188	186	490.5	119	18	561.5	21	129	143	134	119
C 31 2	S3	M3S	195	207.5	205.5	534.5	142	23	630.5	28	160	155	160	142
C 31 2	S3	M3L	195	207.5	205.5	566.5	142	32	657.5	37	160	155	160	142
C 31 3	S05	M05	121	170.5	168.5	491	95	13	557	15	96	119	116	95
C 31 3	S1	M1S	138	179	177	496	108	14	559	16	103	132	124	108
C 31 3	S1	M1L	138	179	177	520	108	15	581	17	103	132	124	108
C 31 3	S2	M2S	156	188	186	548	119	18	619	21	129	143	134	119

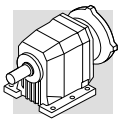

# C 31...P(IEC)

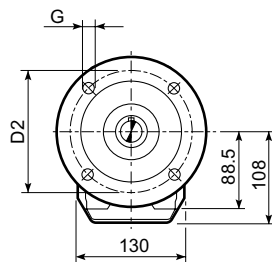
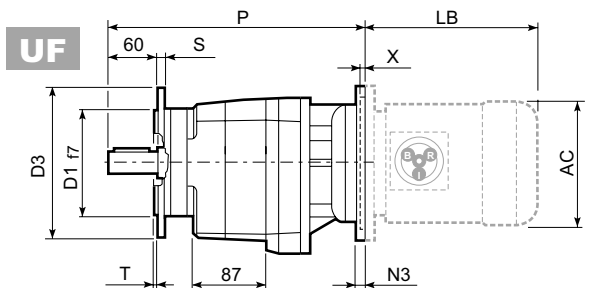
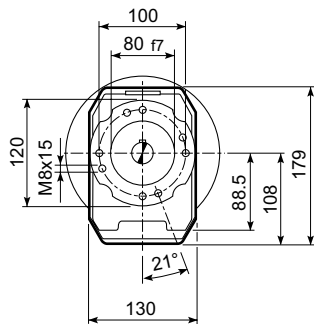
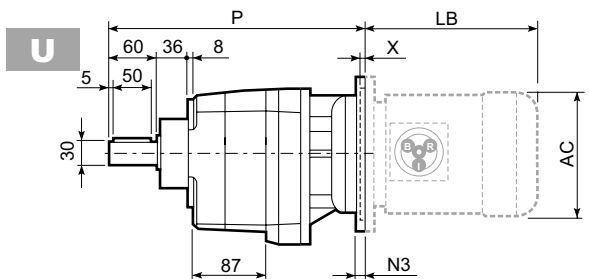
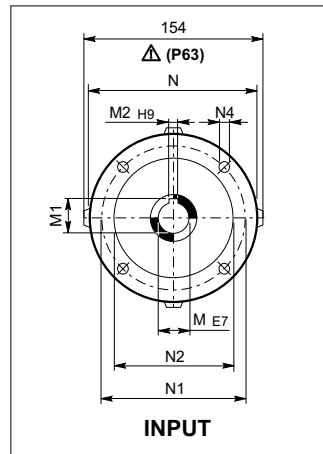
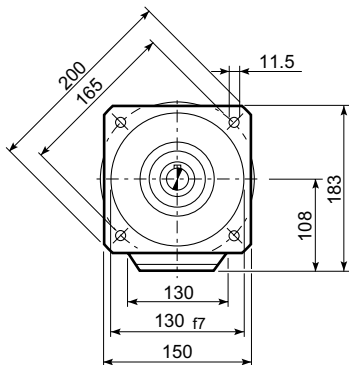
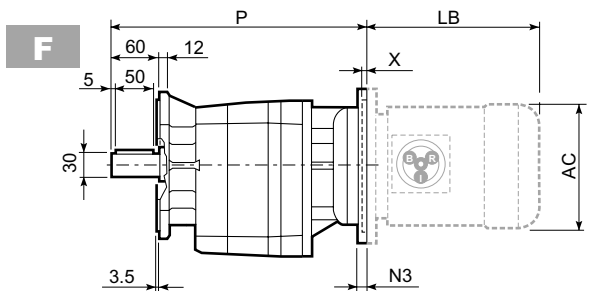
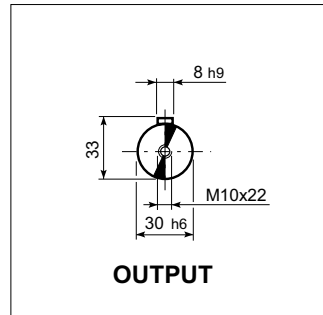
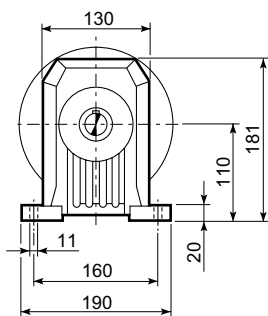
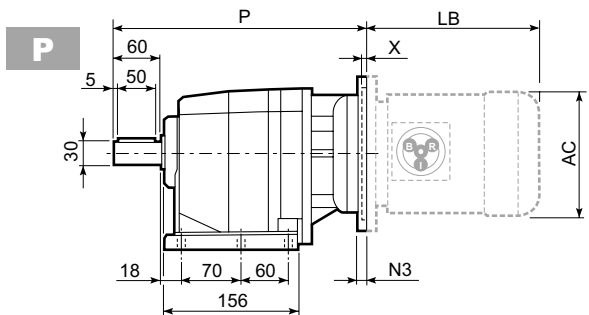

C 31_U						
	D1	D2	D3	G	T	S
FA	110	130	160	9	3	10
FB	130	165	200	11	3.5	11
FC	180	215	250	14	4	13

C 31													BN...		BN...FD BN...FA		
		M	M1	M2	N	N1	N2	N3	N4	X	P	Kg		LB	AC	LB	AC
C 31 2	P63	11	12.8	4	140	115	95	—	M8x19	4	307.5	9	BN 63	184	121	249	121
C 31 2	P71	14	16.3	5	160	130	110	—	M8x16	4.5	307.5	9	BN 71	219	138	280	138
C 31 2	P80	19	21.8	6	200	165	130	—	M10x12	4	327	10	BN 80	234	156	306	156
C 31 2	P90	24	27.3	8	200	165	130	—	M10x12	4	327	10	BN 90	276	176	359	176
C 31 2	P100	28	31.3	8	250	215	180	—	M12x16	4.5	337	14	BN 100	307	195	398	195
C 31 2	P112	28	31.3	8	250	215	180	—	M12x16	4.5	337	14	BN 112	325	219	424	219
C 31 3	P63	11	12.8	4	140	115	95	—	M8x19	4	365	10	BN 63	184	121	249	121
C 31 3	P71	14	16.3	5	160	130	110	—	M8x16	4.5	365	10	BN 71	219	138	280	138
C 31 3	P80	19	21.8	6	200	165	130	—	M10x12	4	384.5	11	BN 80	234	156	306	156
C 31 3	P90	24	27.3	8	200	165	130	—	M10x12	4	384.5	11	BN 90	276	176	359	176
C 31 3	P100	28	31.3	8	250	215	180	—	M12x16	4.5	394.5	15	BN 100	307	195	398	195
C 31 3	P112	28	31.3	8	250	215	180	—	M12x16	4.5	394.5	15	BN 112	325	219	424	219

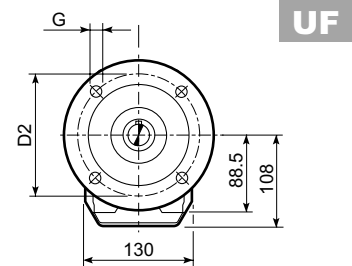
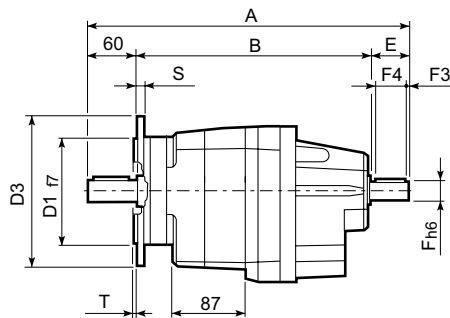
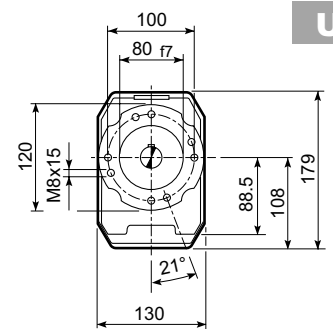
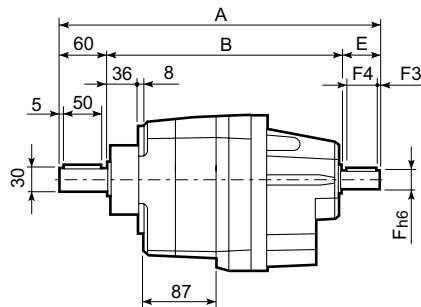
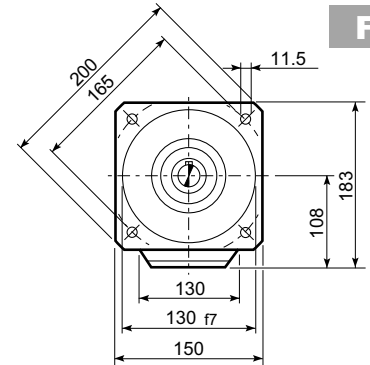
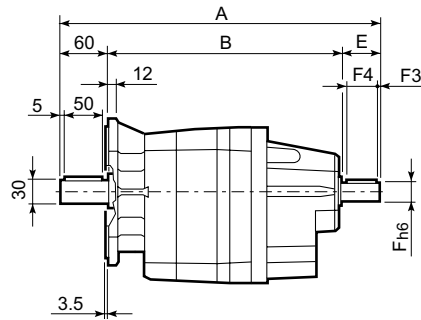
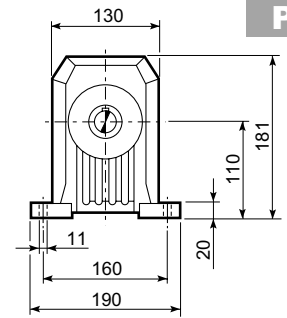
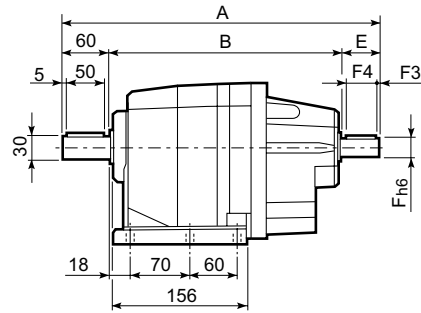
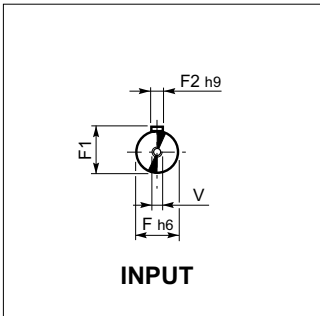
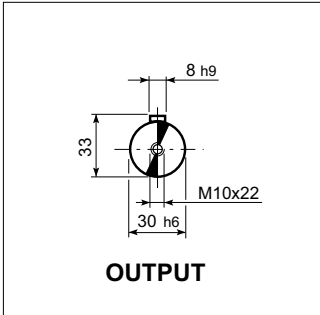
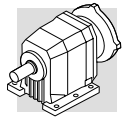

C 31_U						
	D1	D2	D3	G	T	S
FA	110	130	160	9	3	10
FB	130	165	200	11	3.5	11
FC	180	215	250	14	4	13

C 31											
		A	B	E	F	F1	F2	F3	F4	V	kg
	HS	357.5	257.5	40	19	21.5	6	2.5	35	M6x16	11.1
		372	272	40	16	18	5	2.5	36	M6x16	10.6



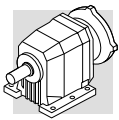

# C 35...M

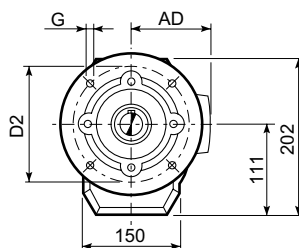
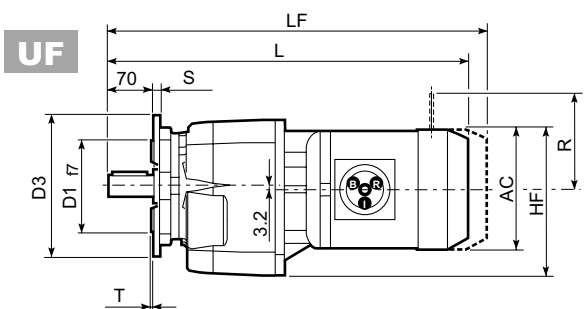
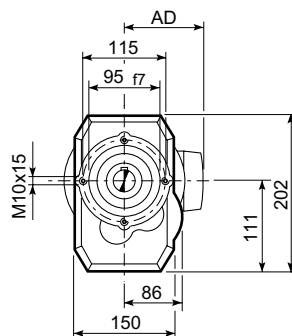
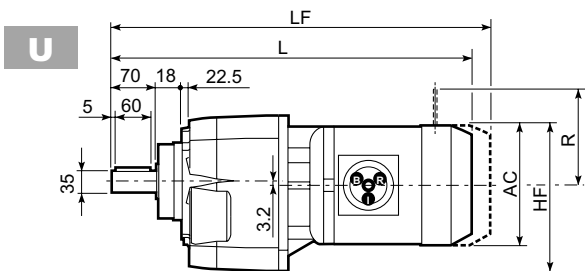
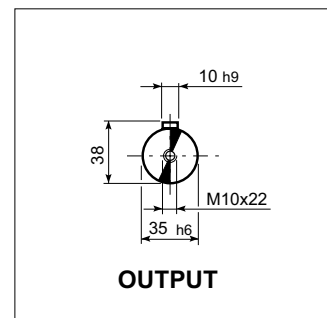
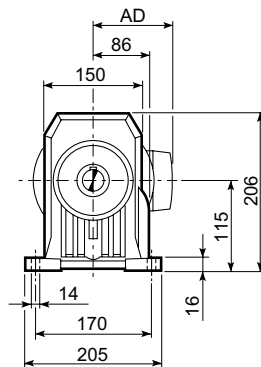
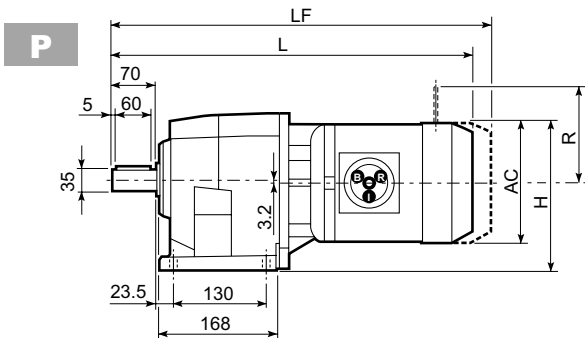

C 35 U						
	D1	D2	D3	G	T	S
FA	130	165	200	11	3.5	11
FB	180	215	250	14	4	14

C 35															
										M...FD M...FA		M...FD		M...FA	
			AC	H	HF	L	AD		LF		R	AD	R	AD	
C 35 2/3	S1	M1S	138	184	177	457	108	20	520	20	103	132	124	108	
C 35 2/3	S1	M1L	138	184	177	481	108	20	542	21	103	132	124	108	
C 35 2/3	S2	M2S	156	193	186	509	119	23	580	27	129	143	134	119	
C 35 2/3	S3	M3S	195	212.5	205.5	553	142	28	649	33	160	155	160	142	
C 35 2/3	S3	M3L	195	212.5	205.5	585	142	37	676	42	160	155	160	142	
C 35 4	S05	M05	121	175.5	168.5	509.5	95	19	575.5	20	96	119	116	95	
C 35 4	S1	M1S	138	184	177	514.5	108	21	577.5	21	103	132	124	108	
C 35 4	S1	M1L	138	184	177	538.5	108	21	599.5	22	103	132	124	108	
C 35 4	S2	M2S	156	193	186	566.5	119	24	637.5	28	129	143	134	119	
C 35 4	S3	M3S	195	212.5	205.5	610.5	142	29	706.5	34	160	155	160	142	
C 35 4	S3	M3L	195	212.5	205.5	642.5	142	38	733.5	43	160	155	160	142	

# C 35...P(IEC)

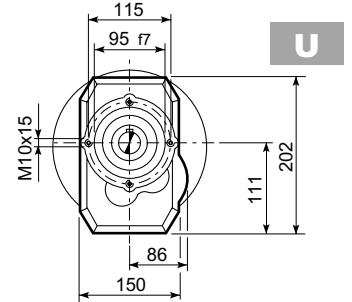
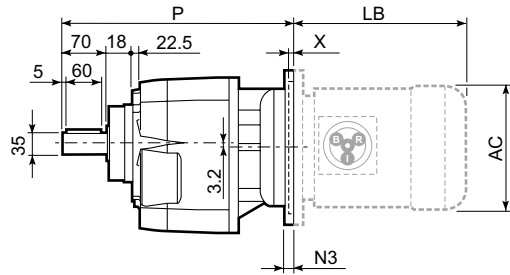
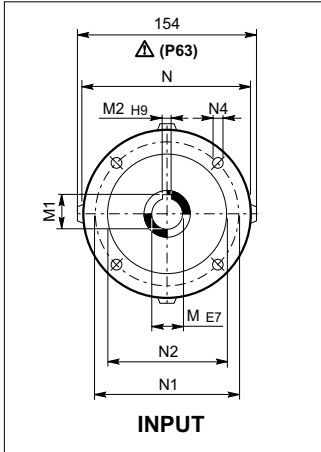
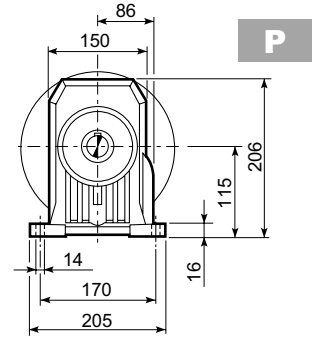
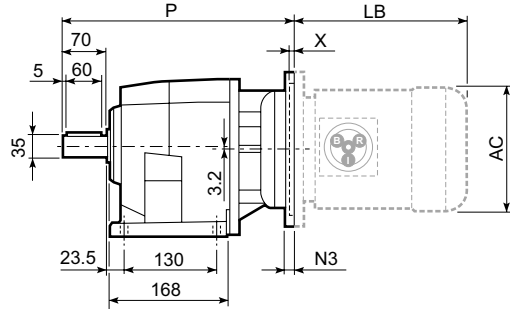
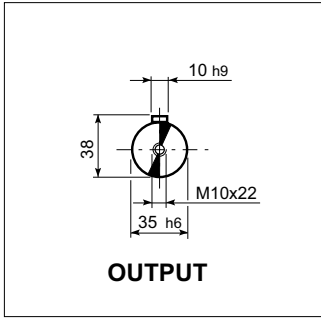
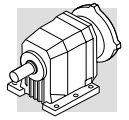

C 35 U						
	D1	D2	D3	G	T	S
FA	130	165	200	11	3.5	11
FB	180	215	250	14	4	14

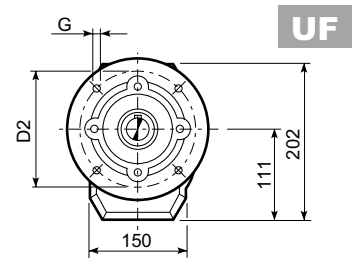
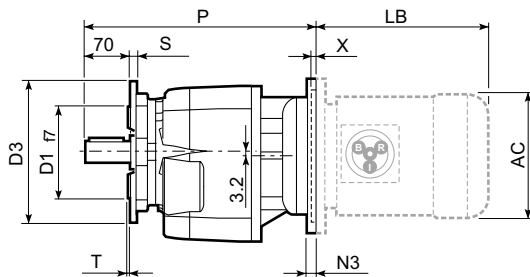

C 35													BN...		BN...FD BN...FA				
		M	M1	M2	N	N1	N2	N3	N4	X	P	Kg	IEC	LB	AC	LB	AC		
		C 35 2/3	P63	11	12.8	4	140	115	95	—	M8x19	4	326	17	BN 63	184	121	249	121
		C 35 2/3	P71	14	16.3	5	160	130	110	—	M8x16	4.5	326	17	BN 71	219	138	280	138
		C 35 2/3	P80	19	21.8	6	200	165	130	—	M10x12	4	345.5	18	BN 80	234	156	306	156
		C 35 2/3	P90	24	27.3	8	200	165	130	—	M10x12	4	345.5	18	BN 90	276	176	359	176
		C 35 2/3	P100	28	31.3	8	250	215	180	—	M12x16	4.5	355.5	22	BN 100	307	195	398	195
		C 35 2/3	P112	28	31.3	8	250	215	180	—	M12x16	4.5	355.5	22	BN 112	325	219	424	219
		C 35 4	P63	11	12.8	4	140	115	95	—	M8x19	4	383.5	20	BN 63	184	121	249	121
		C 35 4	P71	14	16.3	5	160	130	110	—	M8x16	4.5	383.5	20	BN 71	219	138	280	138
		C 35 4	P80	19	21.8	6	200	165	130	—	M10x12	4	403	21	BN 80	234	156	306	156
		C 35 4	P90	24	27.3	8	200	165	130	—	M10x12	4	403	21	BN 90	276	176	359	176
		C 35 4	P100	28	31.3	8	250	215	180	—	M12x16	4.5	413	25	BN 100	307	195	398	195
		C 35 4	P112	28	31.3	8	250	215	180	—	M12x16	4.5	413	25	BN 112	325	219	424	219

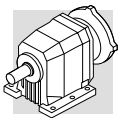

# C 35...HS

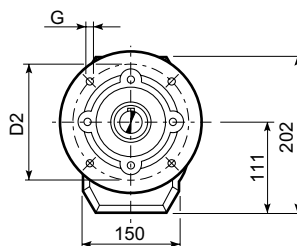
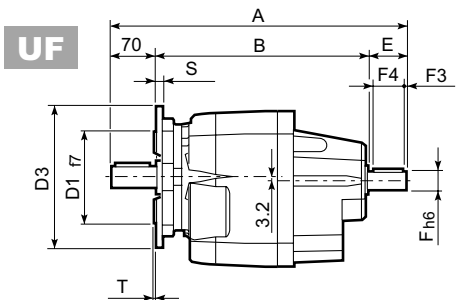
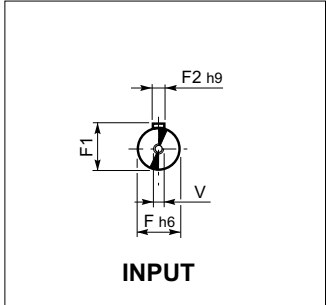
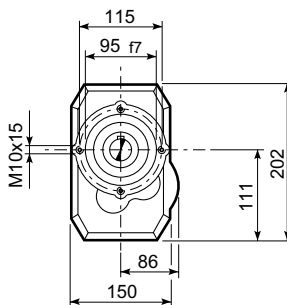
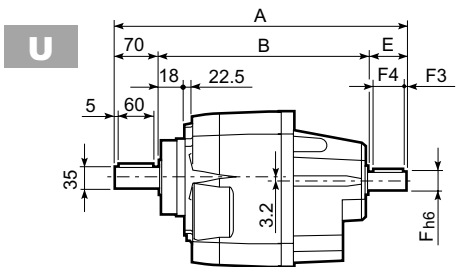
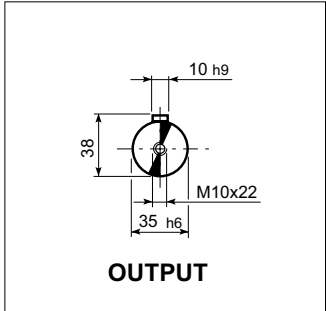
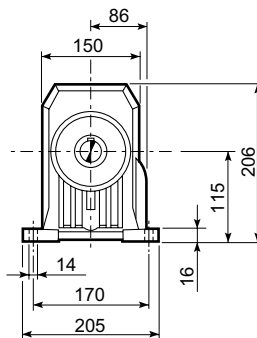
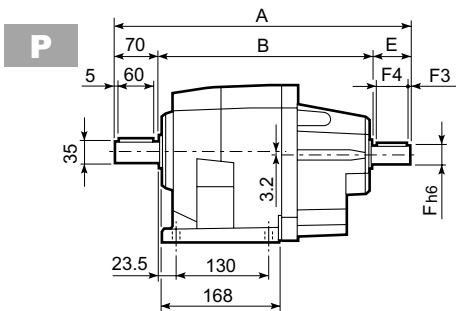

C 35_U						
	D1	D2	D3	G	T	S
FA	130	165	200	11	3.5	11
FB	180	215	250	14	4	14

C 35											
		A	B	E	F	F1	F2	F3	F4	V	kg
C 35 2	HS	415.5	295.5	50	24	27	8	2.5	45	M8x19	25.5
C 35 3		415.5	295.5	50	24	27	8	2.5	45	M8x19	25.5
C 35 4		390.5	280.5	40	16	18	5	2.5	36	M6x16	26.5

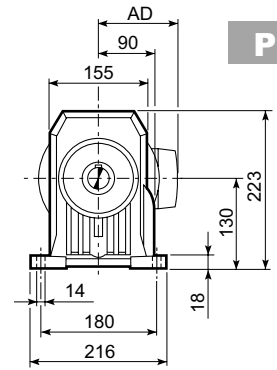
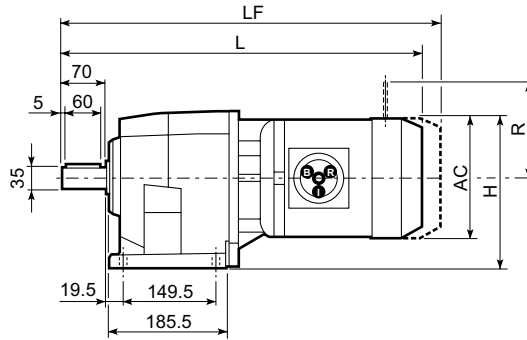
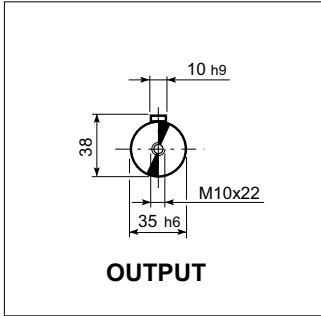
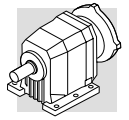

**P**

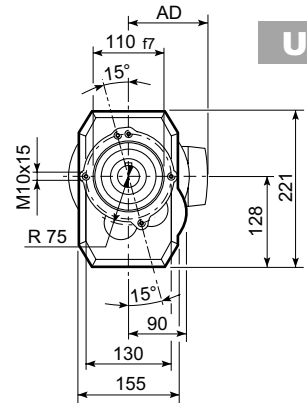
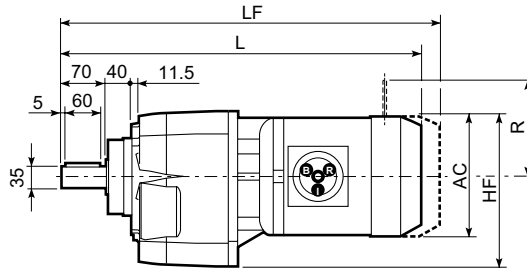

**U**

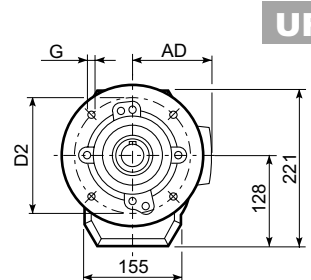
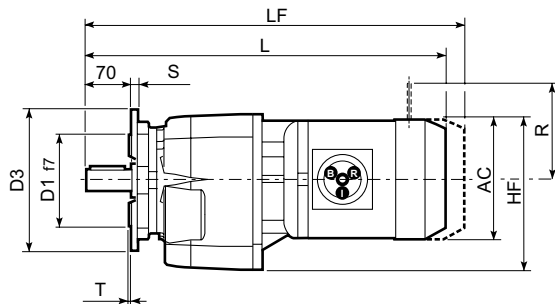

**UF**

C 41 U						
	D1	D2	D3	G	T	S
FA	130	165	200	11	3.5	11
FB	180	215	250	14	4	13

C 41																	
									M...FD M...FA		M...FD		M...FA				
			AC	H	HF	L	AD		LF		R	AD	R	AD			
			C 41 2/3	S1	M1S	138	199	197	467.5	108	25	530.5	27	103	132	124	108
			C 41 2/3	S1	M1L	138	199	197	491.5	108	25	552.5	28	103	132	124	108
			C 41 2/3	S2	M2S	156	208	206	519.5	119	31	590.5	34	129	143	134	119
			C 41 2/3	S3	M3S	195	227.5	225.5	563.5	142	36	659.5	41	160	155	160	142
			C 41 2/3	S3	M3L	195	227.5	225.5	595.5	142	45	686.5	50	160	155	160	142
			C 41 2/3	S4	M4	258	259	257	703.5	193	71	812.5	83	226	193	217	193
			C 41 4	S05	M05	231	245.5	243.5	524	95	27	590	28	96	119	116	95
			C 41 4	S1	M1S	138	199	197	529	108	28	592	30	103	132	124	108
			C 41 4	S1	M1L	138	199	197	553	108	28	614	31	103	132	124	108
			C 41 4	S2	M2S	156	208	206	581	119	34	652	37	129	143	134	119
			C 41 4	S3	M3S	195	227.5	225.5	625	142	39	721	44	160	155	160	142
			C 41 4	S3	M3L	195	227.5	225.5	657	142	48	748	53	160	155	160	142

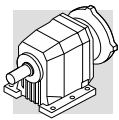

# C 41...P(IEC)

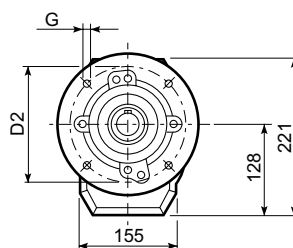
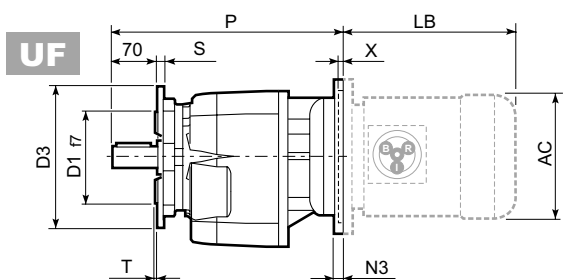
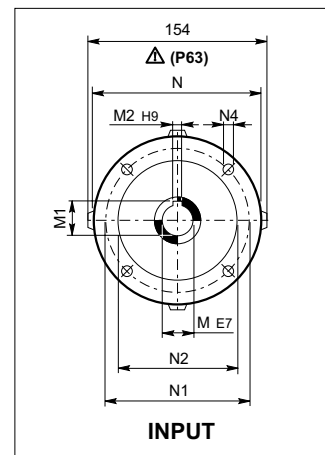
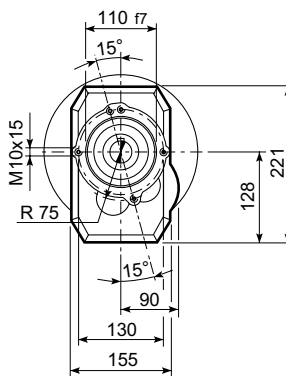
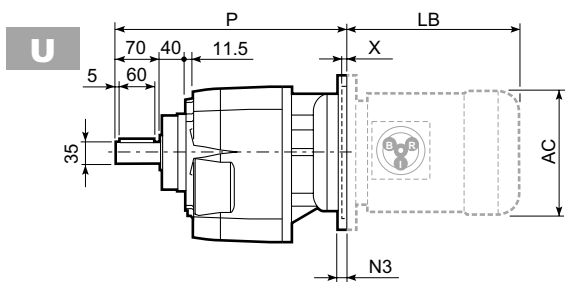
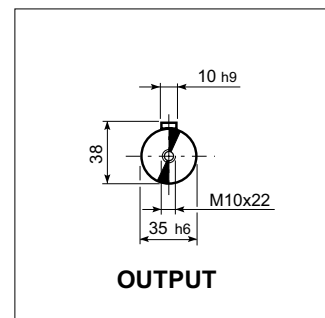
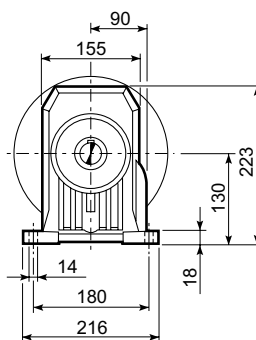
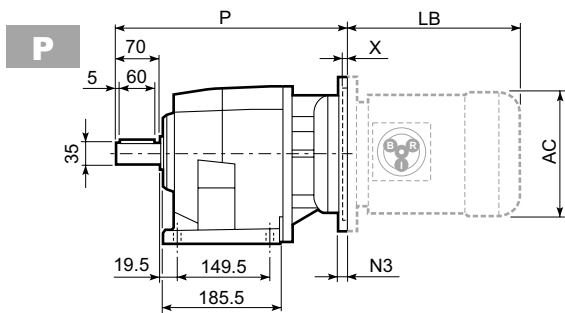

C 41 U						
	D1	D2	D3	G	T	S
FA	130	165	200	11	3.5	11
FB	180	215	250	14	4	13

C 41													BN...		BN...FD BN...FA		
		M	M1	M2	N	N1	N2	N3	N4	X	P		LB	AC	LB	AC	
C 41 2/3	P63	11	12.8	4	140	115	95	—	M8x19	4	336.5	27	BN 63	184	121	249	121
C 41 2/3	P71	14	16.3	5	160	130	110	—	M8x16	4.5	336.5	28	BN 71	219	138	280	138
C 41 2/3	P80	19	21.8	6	200	165	130	—	M10x12	4	356	29	BN 80	234	156	306	156
C 41 2/3	P90	24	27.3	8	200	165	130	—	M10x12	4	356	29	BN 90	276	176	359	176
C 41 2/3	P100	28	31.3	8	250	215	180	—	M12x16	4.5	366	33	BN 100	307	195	398	195
C 41 2/3	P112	28	31.3	8	250	215	180	—	M12x16	4.5	366	33	BN 112	325	219	424	219
C 41 2/3	P132	38	41.3	10	300	265	230	16	14	5	402.5	35	BN 132	413	258	523	258
C 41 4	P63	11	12.8	4	140	115	95	—	M8x19	4	395	30	BN 63	184	121	249	121
C 41 4	P71	14	16.3	5	160	130	110	—	M8x16	4.5	395	31	BN 71	219	138	280	138
C 41 4	P80	19	21.8	6	200	165	130	—	M10x12	4	414.5	32	BN 80	234	156	306	156
C 41 4	P90	24	27.3	8	200	165	130	—	M10x12	4	414.5	32	BN 90	276	176	359	176
C 41 4	P100	28	31.3	8	250	215	180	—	M12x16	4.5	424.5	36	BN 100	307	195	398	195
C 41 4	P112	28	31.3	8	250	215	180	—	M12x16	4.5	424.5	36	BN 112	325	219	424	219

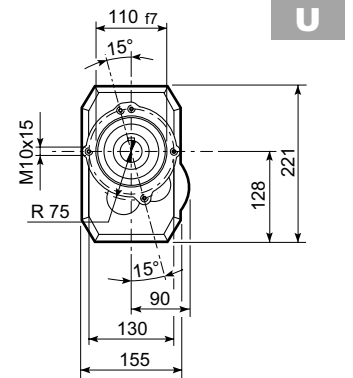
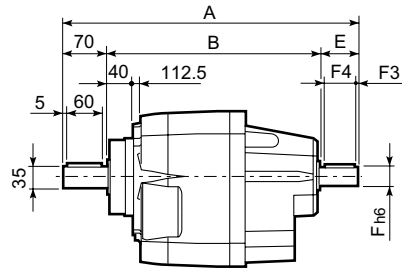
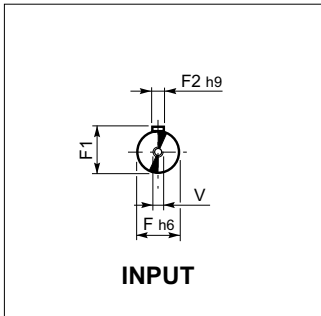
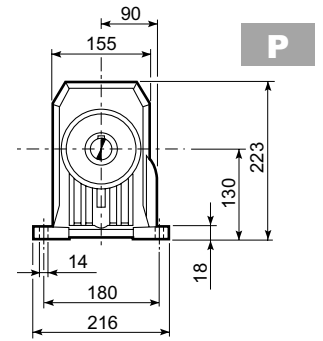
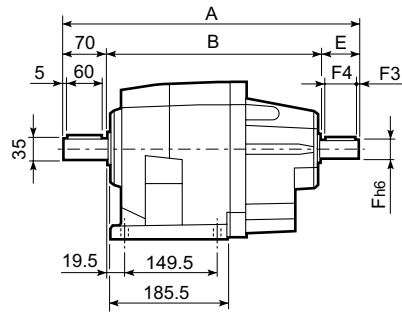
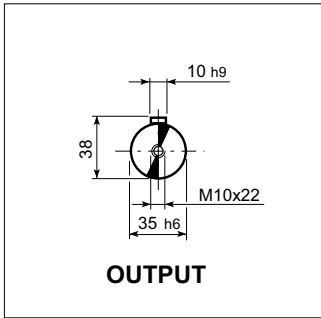
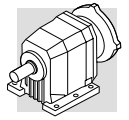

C 41_U						
	D1	D2	D3	G	T	S
FA	130	165	200	11	3.5	11
FB	180	215	250	14	4	13

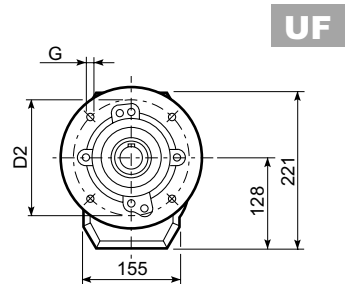
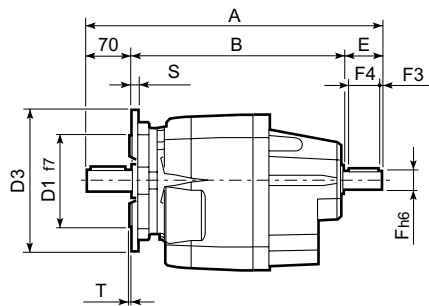

C 41												
		A	B	E	F	F1	F2	F3	F4	V	kg	
	HS	C 41 2	425.5	305.5	50	24	27	8	2.5	45	M8x19	30
		C 41 3	425.5	305.5	50	24	27	8	2.5	45	M8x19	30
		C 41 4	448	338	40	19	21.5	6	2.5	35	M6x16	33

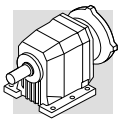

# C 51...M

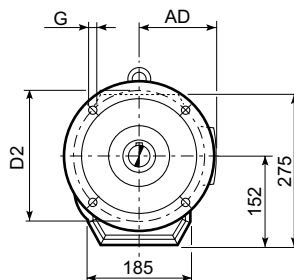
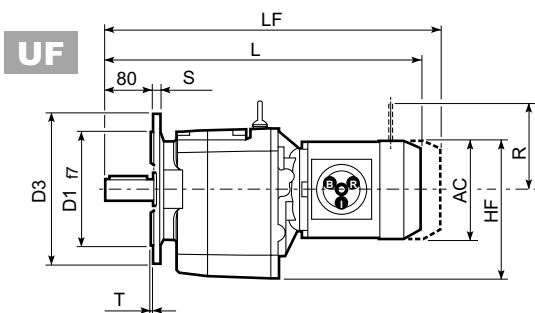
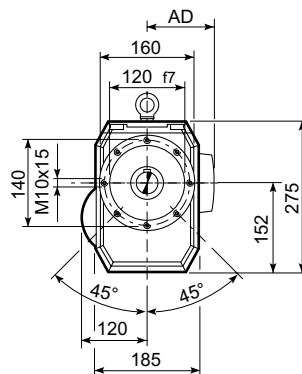
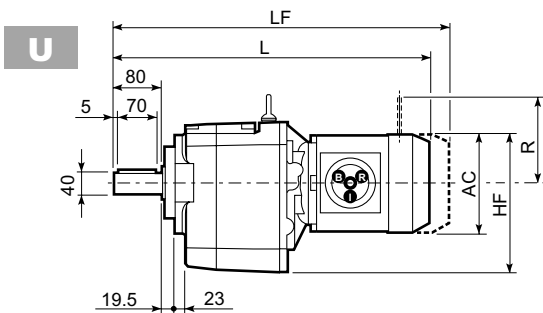
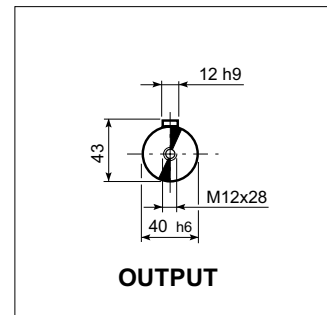
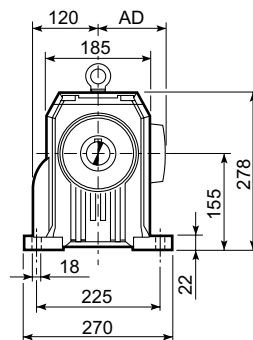
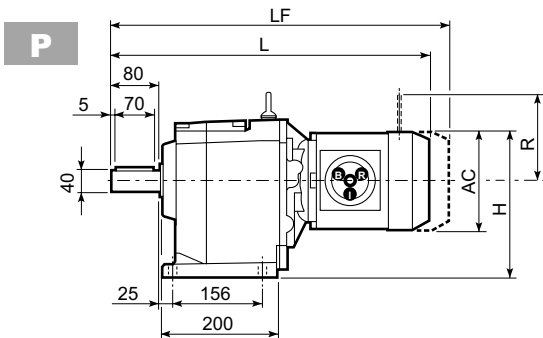

C 51 U						
	D1	D2	D3	G	T	S
FA	180	215	250	14	4	13
FB	230	265	300	14	4	16

C 51																	
										M...FD M...FA		M...FD		M...FA			
			AC	H	HF	L	AD	Kg	LF	Kg	R	AD	R	AD			
			C 51 2/3	S1	M1S	138	224	221	493.5	108	48	556.5	50	103	132	124	108
			C 51 2/3	S1	M1L	138	224	221	517.5	108	49	578.5	52	103	132	124	108
			C 51 2/3	S2	M2S	156	233	230	545.5	119	53	616.5	57	129	143	134	119
			C 51 2/3	S3	M3S	195	252.5	249.5	589.5	142	58	685.5	65	160	155	160	142
			C 51 2/3	S3	M3L	195	252.5	249.5	621.5	142	65	712.5	72	160	155	160	142
			C 51 2/3	S4	M4	258	284	281	729.5	193	99	838.5	117	226	193	217	193
			C 51 2/3	S4	M4LC	258	284	281	764.5	193	107	863.5	125	226	193	217	193
			C 51 4	S1	M1S	138	224	221	565	108	51	628	54	103	132	124	108
			C 51 4	S1	M1L	138	224	221	589	108	52	650	55	103	132	124	108
			C 51 4	S2	M2S	156	233	230	617	119	56	688	60	129	143	134	119
			C 51 4	S3	M3S	195	252.5	249.5	661	142	61	757	68	160	155	160	142
			C 51 4	S3	M3L	195	252.5	249.5	693	142	68	784	75	160	155	160	142

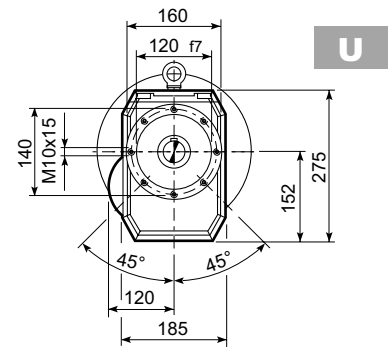
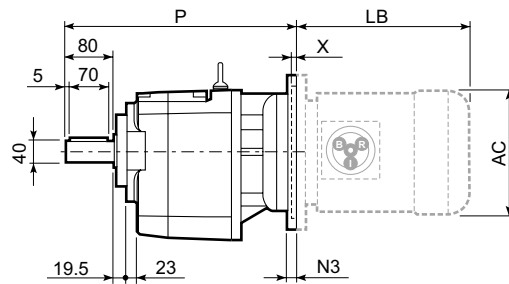
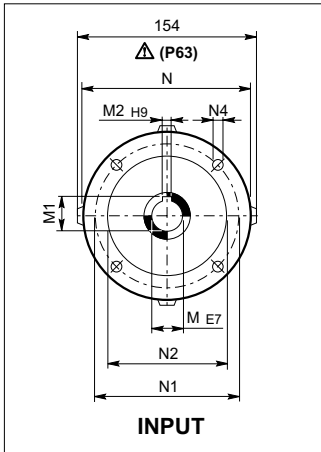
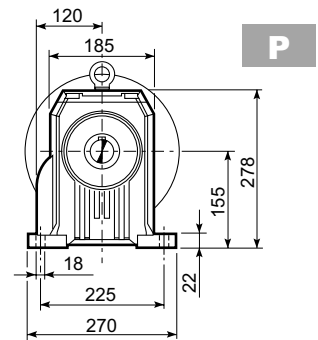
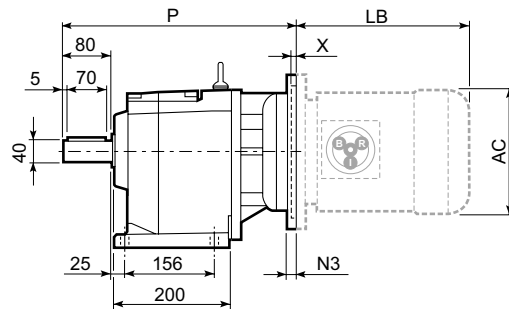
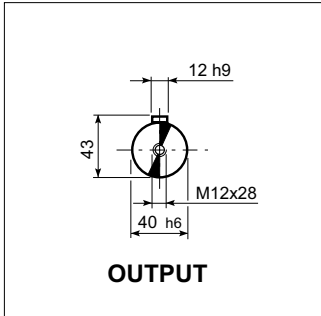
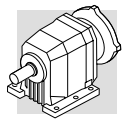

C 51 U						
	D1	D2	D3	G	T	S
FA	180	215	250	14	4	13
FB	230	265	300	14	4	16

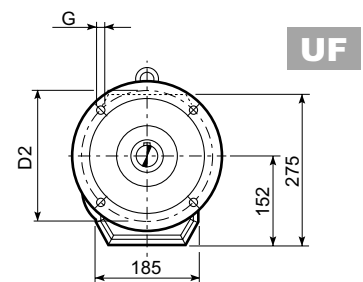
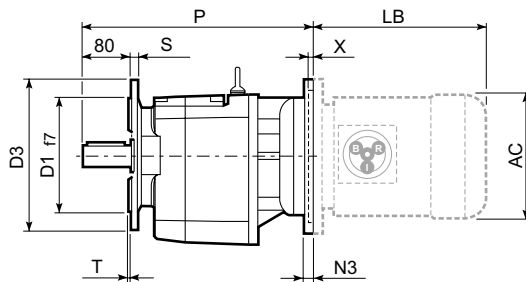

C 51													BN...		BN...FD BN...FA				
		M	M1	M2	N	N1	N2	N3	N4	X	P	Kg		LB	AC	LB	AC		
		C 51 2/3	P63	11	12.8	4	140	115	95	—	M8x19	4	362.5	45	BN 63	184	121	249	121
		C 51 2/3	P71	14	16.3	5	160	130	110	—	M8x16	4.5	362.5	45	BN 71	219	138	280	138
		C 51 2/3	P80	19	21.8	6	200	165	130	—	M10x12	4	382	47	BN 80	234	156	306	156
		C 51 2/3	P90	24	27.3	8	200	165	130	—	M10x12	4	382	47	BN 90	276	176	359	176
		C 51 2/3	P100	28	31.3	8	250	215	180	—	M12x16	4.5	392	51	BN 100	307	195	398	195
		C 51 2/3	P112	28	31.3	8	250	215	180	—	M12x16	4.5	392	51	BN 112	325	219	424	219
		C 51 2/3	P132	38	41.3	10	300	265	230	16	14	5	428.5	54	BN 132	413	258	523	258
		C 51 2/3	P160	42	45.3	12	350	300	250	23	18	5.5	479	58	BN 160MR	452	258	562	258
															BN 160M/L	486	310	626	310
		C 51 2/3	P180	48	51.8	14	350	300	250	23	18	5.5	479	58	BN 180M	530	310	670	310
															BN 180L	598	348	756	348
		C 51 4	P63	11	12.8	4	140	115	95	—	M8x19	4	434	47	BN 63	184	121	249	121
		C 51 4	P71	14	16.3	5	160	130	110	—	M8x16	4.5	434	47	BN 71	219	138	280	138
		C 51 4	P80	19	21.8	6	200	165	130	—	M10x12	4	453.5	49	BN 80	234	156	306	156
		C 51 4	P90	24	27.3	8	200	165	130	—	M10x12	4	463.5	49	BN 90	276	176	359	176
		C 51 4	P100	28	31.3	8	250	215	180	—	M12x16	4.5	463.5	53	BN 100	307	195	398	195
		C 51 4	P112	28	31.3	8	250	215	180	—	M12x16	4.5	463.5	53	BN 112	325	219	424	219



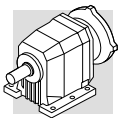

# C 51...HS

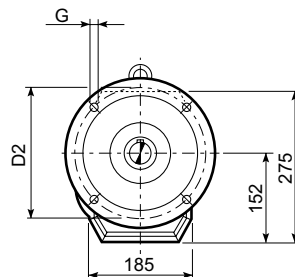
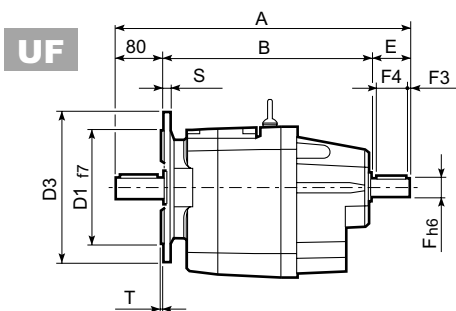
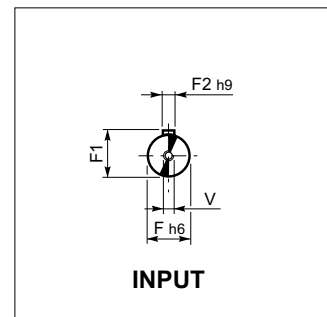
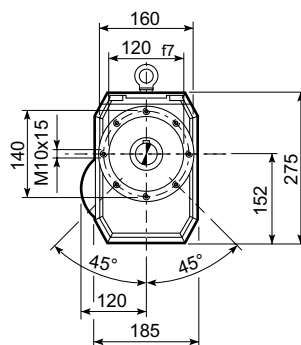
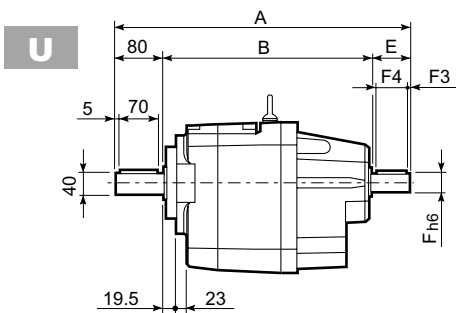
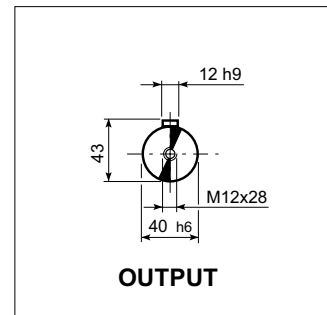
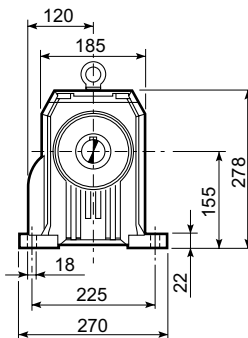
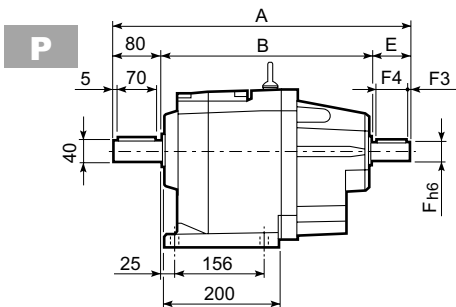

C 51 U						
	D1	D2	D3	G	T	S
FA	180	215	250	14	4	13
FB	230	265	300	14	4	16

C 51											
		A	B	E	F	F1	F2	F3	F4	V	kg
C 51 2	HS	451.5	322	50	24	24	8	2.5	45	M8x19	45
C 51 3		451.5	322	50	24	24	8	2.5	45	M8x19	45
C 51 4		484	364	40	19	21.5	6	2.5	35	M6x16	48

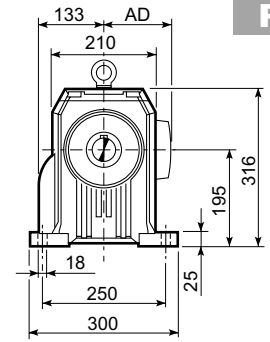
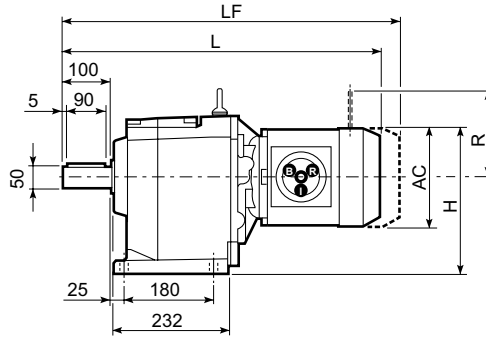
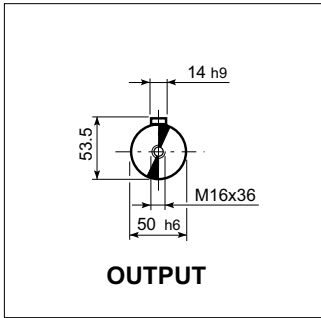
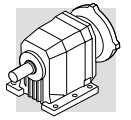

**P**

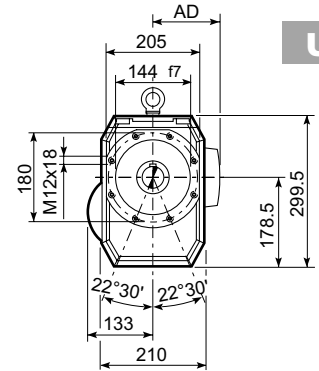
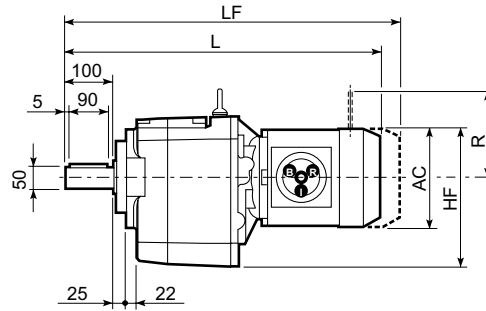

**U**

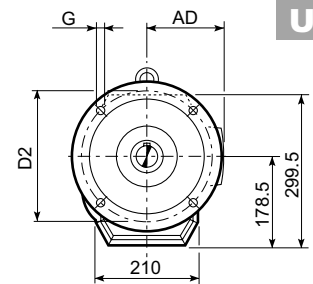
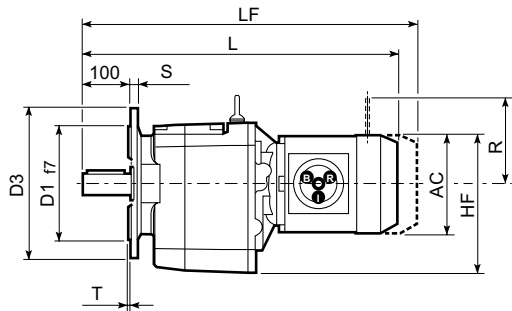

**UF**

C 61_U						
	D1	D2	D3	G	T	S
FA	230	265	300	14	4	16
FB	250	300	350	18	5	18

C 61																	
										M...FD M...FA		M...FD		M...FA			
			AC	H	HF	L	AD		LF		R	AD	R	AD			
			C 61 2/3	S2	M2S	156	273	256.5	598.5	119	61	669.5	65	129	143	134	119
			C 61 2/3	S3	M3S	195	292.5	276	642.5	142	66	738.5	74	160	155	160	142
			C 61 2/3	S3	M3L	195	292.5	276	674.5	142	74	765.5	81	160	155	160	142
			C 61 2/3	S4	M4	258	324	307.5	782.5	193	108	891.5	126	226	193	217	193
			C 61 2/3	S4	M4LC	258	324	307.5	817.5	193	116	916.5	134	226	193	217	193
			C 61 2/3	S5	M5S	310	350	333.5	869	245	136	1009	166	266	245	247	245
			C 61 2/3	S5	M5L	310	350	333.5	913	245	152	1053	182	266	245	247	245
			C 61 4	S1	M1S	138	264	247.5	617	108	69	680	72	103	132	124	108
			C 61 4	S1	M1L	138	264	247.5	641	108	71	702	74	103	132	124	108
			C 61 4	S2	M2S	156	273	256.5	669	119	75	740	78	129	143	134	119
			C 61 4	S3	M3S	195	292.5	276	713	142	79	809	87	160	155	160	142
			C 61 4	S3	M3L	195	292.5	276	745	142	87	836	94	160	155	160	142

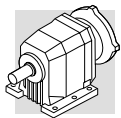

# C 61...P(IEC)

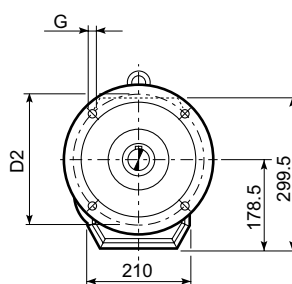
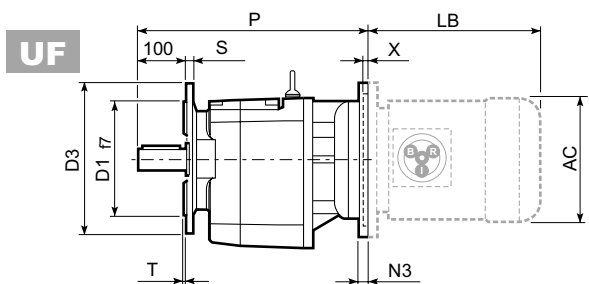
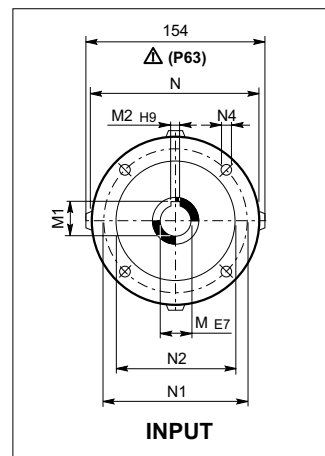
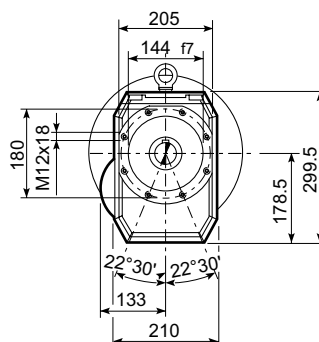
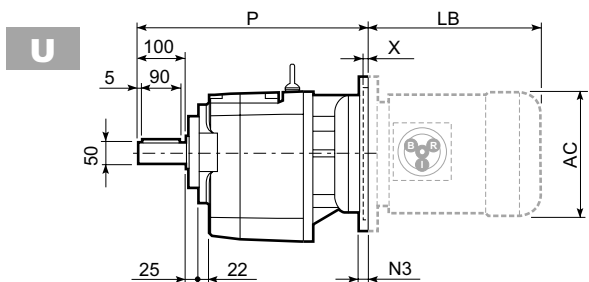
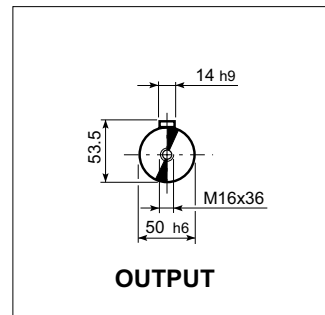
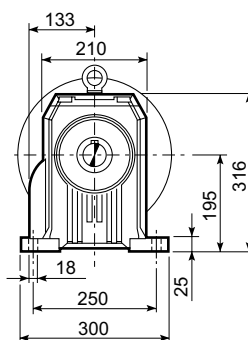
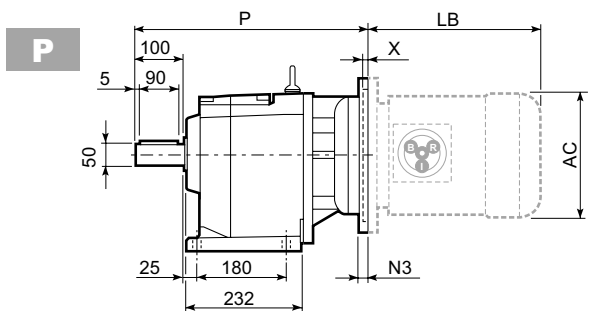

**C 61\_U**

	D1	D2	D3	G	T	S
FA	230	265	300	14	4	16
FB	250	300	350	18	5	18

C 61													BN...		BN...FD BN...FA			
		M	M1	M2	N	N1	N2	N3	N4	X	P			LB	AC	LB	AC	
C 61 2/3	P63	11	12.8	4	140	115	95	—	M8x19	4	415.5	55		BN 63	184	121	249	121
C 61 2/3	P71	14	16.3	5	160	130	110	—	M8x16	4.5	415.5	57		BN 71	219	138	280	138
C 61 2/3	P80	19	21.8	6	200	165	130	—	M10x12	4	435	61		BN 80	234	156	306	156
C 61 2/3	P90	24	27.3	8	200	165	130	—	M10x12	4	435	61		BN 90	276	176	359	176
C 61 2/3	P100	28	31.3	8	250	215	180	—	M12x16	4.5	444	65		BN 100	307	195	398	195
C 61 2/3	P112	28	31.3	8	250	215	180	—	M12x16	4.5	444	65		BN 112	325	219	424	219
C 61 2/3	P132	38	41.3	10	300	265	230	16	14	5	481.5	68		BN 132	413	258	523	258
C 61 2/3	P160	42	45.3	12	350	300	250	23	18	5.5	532	73		BN 160MR	452	258	562	258
														BN 160M/L	486	310	626	310
C 61 2/3	P180	48	51.8	14	350	300	250	23	18	5.5	532	73		BN 180M	530	310	670	310
														BN 180L	598	348	756	348
C 61 4	P63	11	12.8	4	140	115	95	—	M8x19	4	486	61		BN 63	184	121	249	121
C 61 4	P71	14	16.3	5	160	130	110	—	M8x16	4.5	489	63		BN 71	219	138	280	138
C 61 4	P80	19	21.8	6	200	165	130	—	M10x12	4	505.5	67		BN 80	234	156	306	156
C 61 4	P90	24	27.3	8	200	165	130	—	M10x12	4	505.5	67		BN 90	276	176	359	176
C 61 4	P100	28	31.3	8	250	215	180	—	M12x16	4.5	515.5	71		BN 100	307	195	398	195
C 61 4	P112	28	31.3	8	250	215	180	—	M12x16	4.5	515.5	71		BN 112	325	219	424	219

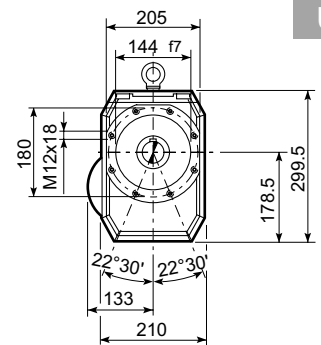
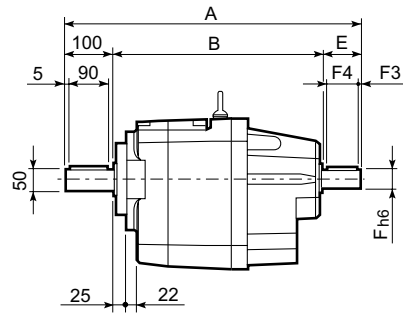
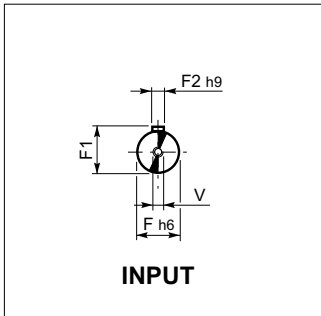
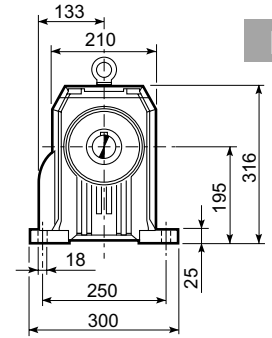
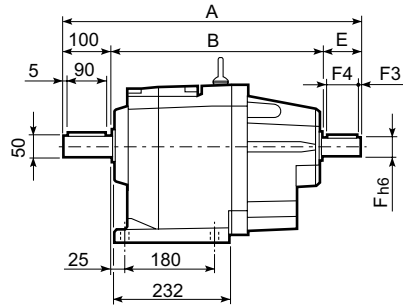
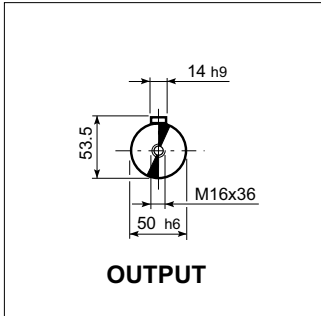
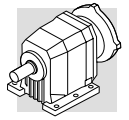

C 61 U						
	D1	D2	D3	G	T	S
FA	230	265	300	14	4	16
FB	250	300	350	18	5	18

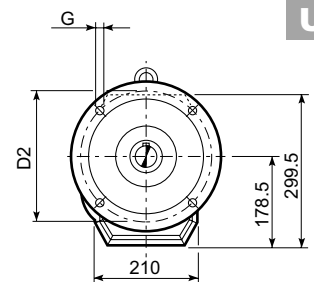
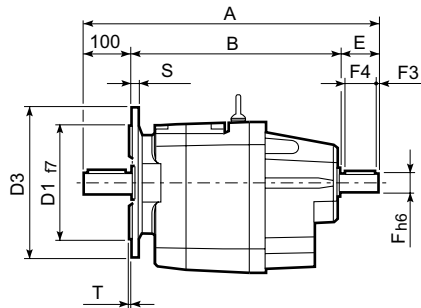

C 61											
		A	B	E	F	F1	F2	F3	F4	V	kg
C 61 2	HS	532	372	60	28	31	8	5	50	M10x22	66
C 61 3		532	372	60	28	31	8	5	50	M10x22	66
C 61 4		575	425	50	24	27	8	2.5	45	M8x19	72

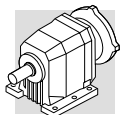

# C 70...M

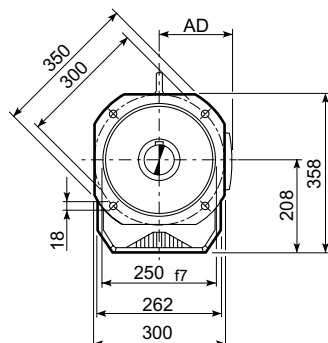
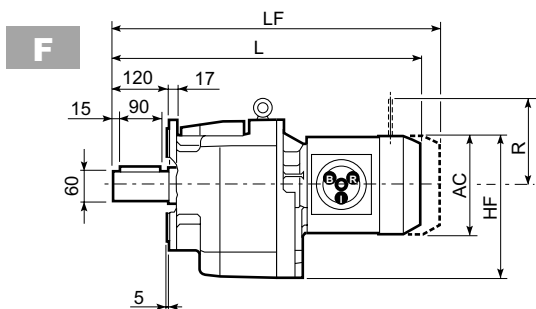
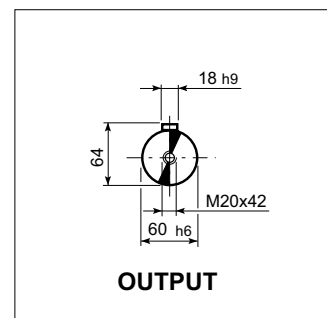
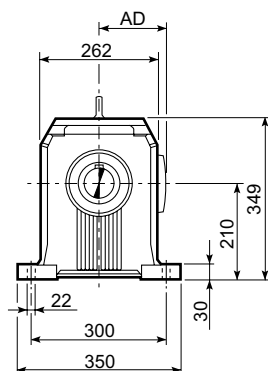
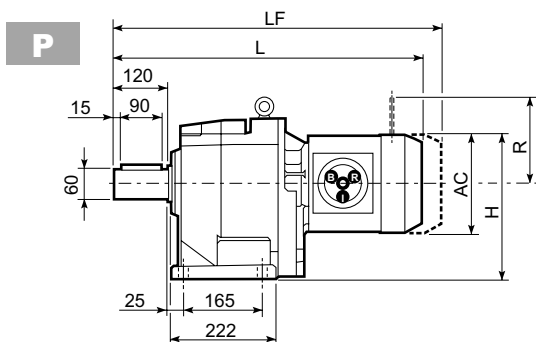

C 70																	
									M...FD M...FA		M...FD		M...FA				
			AC	H	HF	L	AD		LF		R	AD	R	AD			
			C 70 2/3	S2	M2S	156	288	286	636.5	119	88	707.5	92	129	143	134	119
			C 70 2/3	S3	M3S	195	307.5	305.5	680.5	142	93	776.5	101	160	155	160	142
			C 70 2/3	S3	M3L	195	307.5	305.5	712.5	142	101	803.5	108	160	155	160	142
			C 70 2/3	S4	M4	258	339	337	820.5	193	135	929.5	153	226	193	217	193
			C 70 2/3	S4	M4LC	258	339	337	855.5	193	143	954.5	161	226	193	217	193
			C 70 2/3	S5	M5S	310	365	363	907	245	163	1047	193	266	245	247	245
			C 70 2/3	S5	M5L	310	365	363	951	245	179	1091	209	266	245	247	245
			C 70 4	S1	M1S	138	279	277	635.5	108	87	698.5	90	103	132	124	108
			C 70 4	S1	M1L	138	279	277	659.5	108	88	720.5	91	103	132	124	108
			C 70 4	S2	M2S	156	288	286	687.5	119	92	758.5	96	129	143	134	119
			C 70 4	S3	M3S	195	307.5	305.5	731.5	142	97	827.5	104	160	155	160	142
			C 70 4	S3	M3L	195	307.5	305.5	763.5	142	104	854.5	111	160	155	160	142
			C 70 4	S4	M4	258	339	337	871.5	193	138	980.5	156	226	193	217	193

# C 70...P(IEC)

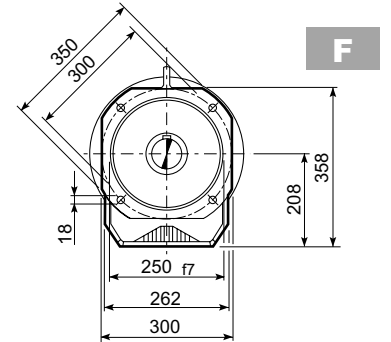
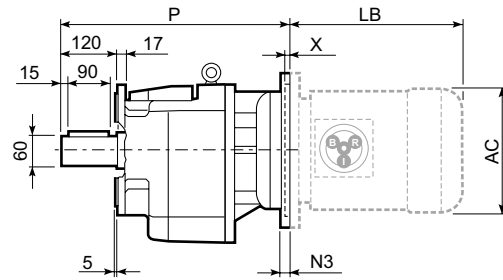
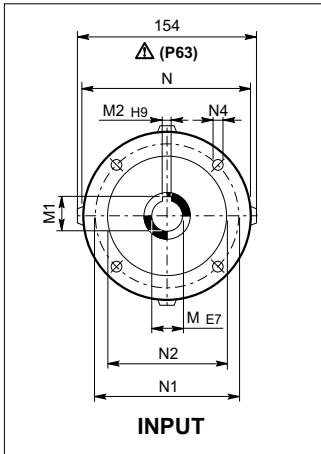
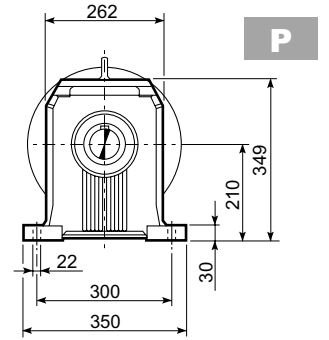
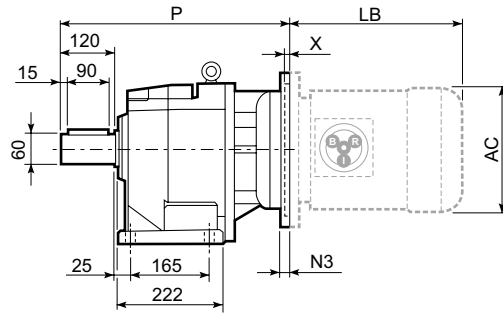
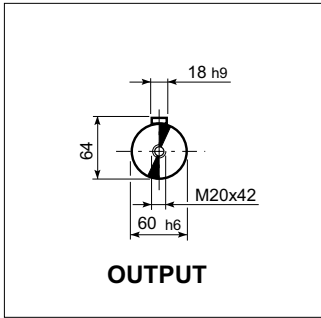
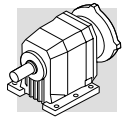

C 70													BN...		BN...FD BN...FA		
		M	M1	M2	N	N1	N2	N3	N4	X	P			LB	AC	LB	AC
C 70 2/3	P80	19	21.8	6	200	165	130	—	M10x12	4	473	88	BN 80	234	156	306	156
C 70 2/3	P90	24	27.3	8	200	165	130	—	M10x12	4	473	88	BN 90	276	176	359	176
C 70 2/3	P100	28	31.3	8	250	215	180	—	M12x16	4.5	483	92	BN 100	307	195	398	195
C 70 2/3	P112	28	31.3	8	250	215	180	—	M12x16	4.5	483	92	BN 112	325	219	424	219
C 70 2/3	P132	38	41.3	10	300	265	230	16	14	5	519.5	95	BN 132	413	258	523	258
C 70 2/3	P160	42	45.3	12	350	300	250	23	18	6	575	107	BN 160MR	452	258	562	258
													BN 160M/L	486	310	626	310
													BN 180M	530	310	670	310
C 70 2/3	P180	48	51.8	14	350	300	250	23	18	6	575	107	BN 180L	598	348	756	348
													BN 200L	612	348	768	348
C 70 2/3	P200	55	59.3	16	400	350	300	—	M16x25	7	600	129	BN 200L	612	348	768	348
C 70 4	P63	11	12.8	4	140	115	95	—	M8x19	4	504.5	91	BN 63	184	121	249	121
C 70 4	P71	14	16.3	5	160	130	110	—	M8x16	4.5	504.5	91	BN 71	219	138	280	138
C 70 4	P80	19	21.8	6	200	165	130	—	M10x12	4	524	92	BN 80	234	156	306	156
C 70 4	P90	24	27.3	8	200	165	130	—	M10x12	4	524	92	BN 90	276	176	359	176
C 70 4	P100	28	31.3	8	250	215	180	—	M12x16	4.5	534	96	BN 100	307	195	398	195
C 70 4	P112	28	31.3	8	250	215	180	—	M12x16	4.5	534	96	BN 112	325	219	424	219
C 70 4	P132	38	41.3	10	300	265	230	16	14	5	570.5	98	BN 132	413	258	523	258

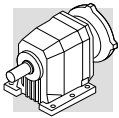

# C 70...HS

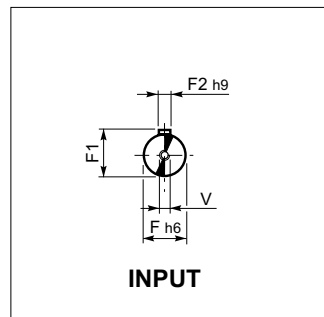
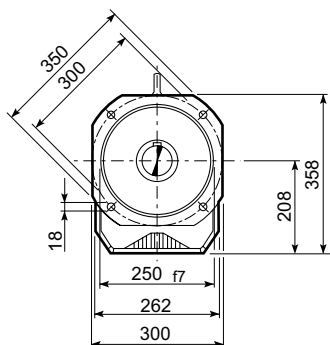
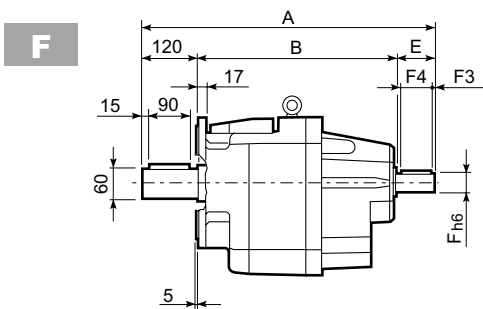
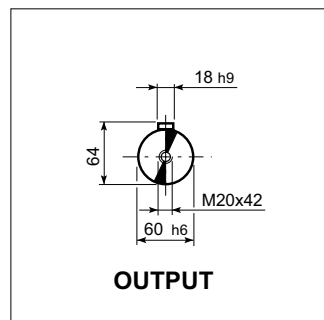
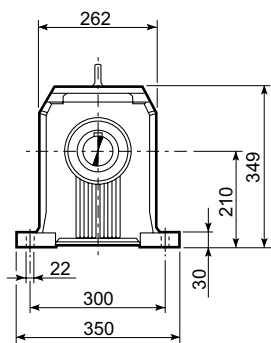
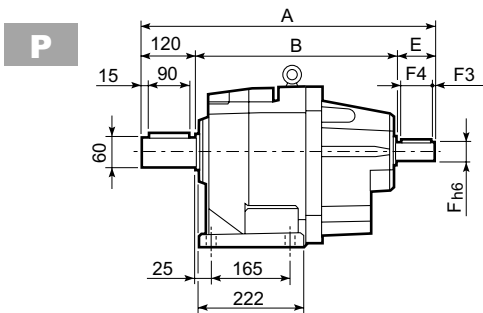

C 70											
		A	B	E	F	F1	F2	F3	F4	V	kg
	HS	657.5	427.5	110	42	45	12	10	90	M12x28	108
		657.5	427.5	110	42	45	12	10	90	M12x28	108
		593.5	423.5	50	24	27	8	2.5	45	M8x19	94

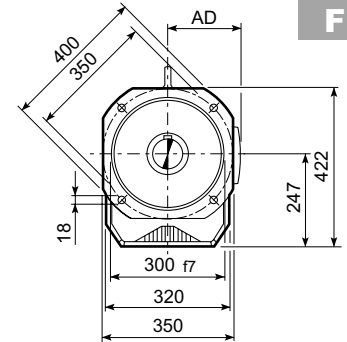
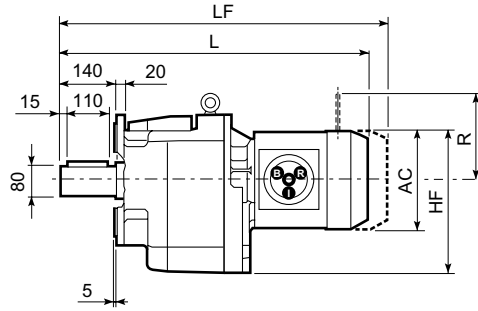
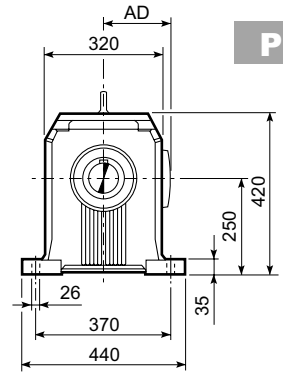
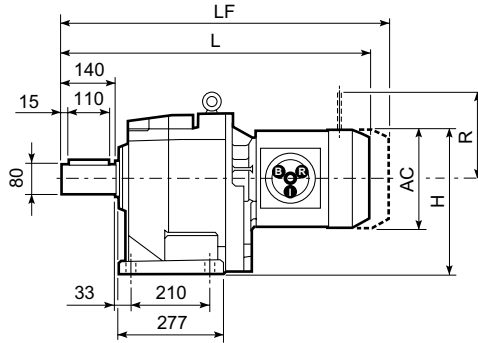
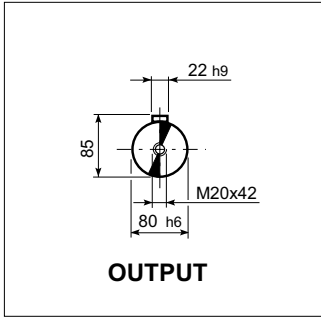
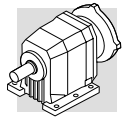

C 80																	
										M...FD M...FA		M...FD		M...FA			
			AC	H	HF	L	AD	Kg	LF	Kg	R	AD	R	AD			
			C 80 2/3	S3	M3S	195	347.5	344.5	742.5	142	139	838.5	146	160	155	160	142
			C 80 2/3	S3	M3L	195	347.5	344.5	774.5	142	146	865.5	153	160	155	160	142
			C 80 2/3	S4	M4	258	379	376	882.5	193	180	991.5	196	226	193	217	193
			C 80 2/3	S4	M4LC	258	379	376	917.5	193	188	1016.5	204	226	193	217	193
			C 80 2/3	S5	M5S	310	405	402	969	245	208	1109	238	266	245	247	245
			C 80 2/3	S5	M5L	310	405	402	1013	245	224	1153	254	266	245	247	245
			C 80 4	S1	M1S	138	319	316	709.5	108	132	772.5	135	103	132	124	108
			C 80 4	S1	M1L	138	319	316	733.5	108	133	794.5	136	103	132	124	108
			C 80 4	S2	M2S	156	328	325	761.5	119	137	832.5	141	129	143	134	119
			C 80 4	S3	M3S	195	347.5	344.5	805.5	142	142	901.5	149	160	155	160	142
			C 80 4	S3	M3L	195	347.5	344.5	837.5	142	149	928.5	156	160	155	160	142
			C 80 4	S4	M4	258	379	376	945.5	193	183	1054.5	201	226	193	217	193



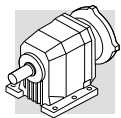

# C 80...P(IEC)

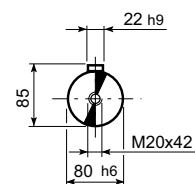
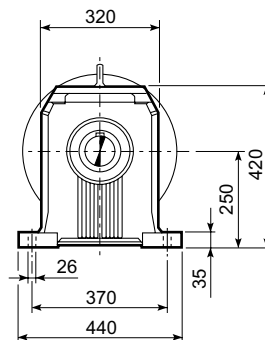
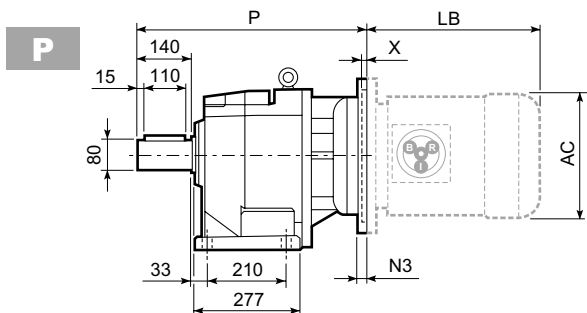

**OUTPUT**

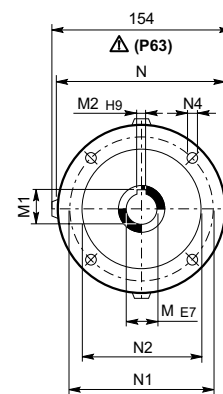
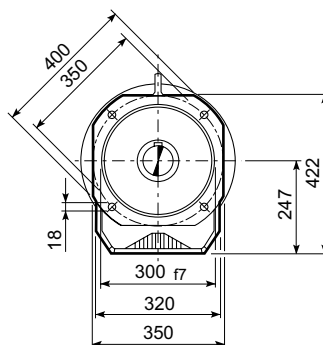
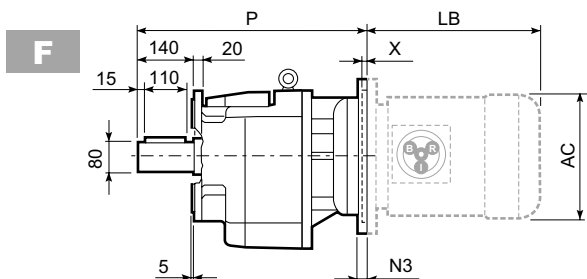

**INPUT  
P63...P200**

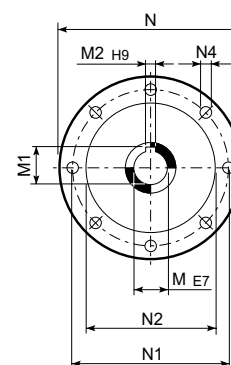

**INPUT  
P225**

C 80													IEC	BN...		BN...FD BN...FA	
		M	M1	M2	N	N1	N2	N3	N4	X	P	Kg		LB	AC	LB	AC
C 80 2/3	P80	19	21.8	6	200	165	130	—	M10x12	4	533	135	BN 80	234	156	306	156
C 80 2/3	P90	24	27.3	8	200	165	130	—	M10x12	4	533	135	BN 90	276	176	359	176
C 80 2/3	P100	28	31.3	8	250	215	180	—	M12x16	4.5	543	139	BN 100	307	195	398	195
C 80 2/3	P112	28	31.3	8	250	215	180	—	M12x16	4.5	543	139	BN 112	325	219	424	219
C 80 2/3	P132	38	41.3	10	300	265	230	16	14	5	579.5	141	BN 132	413	258	523	258
C 80 2/3	P160	42	45.3	12	350	300	250	23	18	6	635	154	BN 160MR	452	258	562	258
													BN 160M/L	486	310	626	310
C 80 2/3	P180	48	51.8	14	350	300	250	23	18	6	635	154	BN 180M	530	310	670	310
													BN 180L	598	348	756	348
C 80 2/3	P200	55	59.3	16	400	350	300	—	M16x25	7	660	176	BN 200L	612	348	768	348
C 80 2/3	P225	60	64.4	18	450	400	350	25	18	6	705.5	178	BN 225	—	—	—	—
C 80 4	P63	11	12.8	4	140	115	95	—	M8x19	4	576.5	138	BN 63	184	121	249	121
C 80 4	P71	14	16.3	5	160	130	110	—	M8x16	4.5	576.5	138	BN 71	219	138	280	138
C 80 4	P80	19	21.8	6	200	165	130	—	M10x12	4	596	140	BN 80	234	156	306	156
C 80 4	P90	24	27.3	8	200	165	130	—	M10x12	4	596	140	BN 90	276	176	359	176
C 80 4	P100	28	31.3	8	250	215	180	—	M12x16	4.5	606	144	BN 100	307	195	398	195
C 80 4	P112	28	31.3	8	250	215	180	—	M12x16	4.5	606	144	BN 112	325	219	424	219
C 80 4	P132	38	41.3	10	300	265	230	16	M12x16	5	642.5	146	BN 132	413	258	523	258

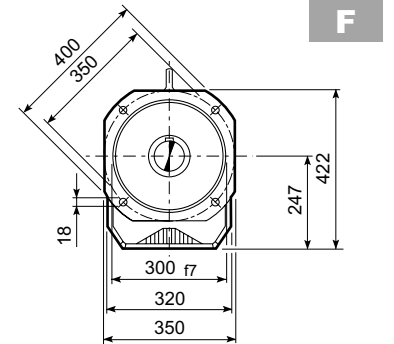
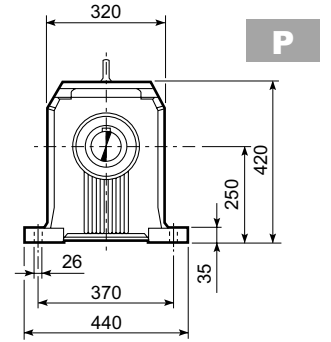
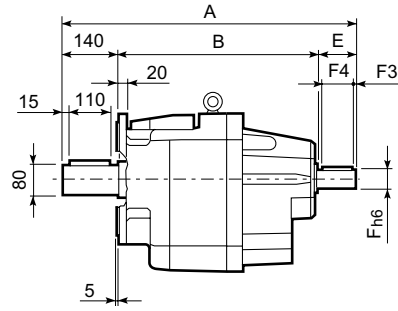
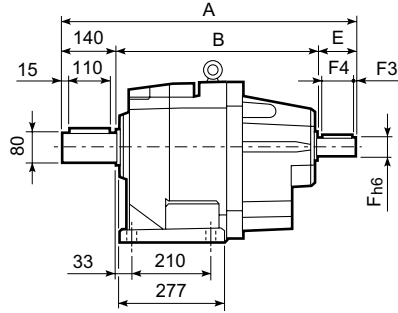
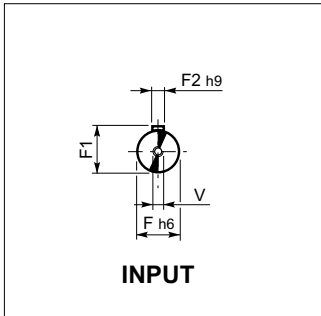
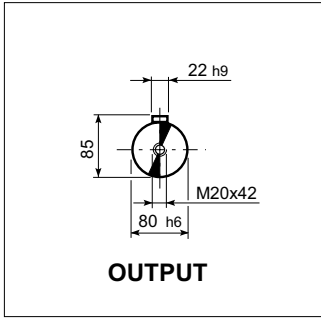
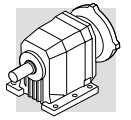

C 80											
		A	B	E	F	F1	F2	F3	F4	V	kg
	HS	718.5	468.5	110	42	45	12	10	90	M12x28	154
		718.5	468.5	110	42	45	12	10	90	M12x28	154
		666.5	476.5	50	24	27	8	2.5	45	M8x19	141

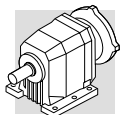

# C 90...M

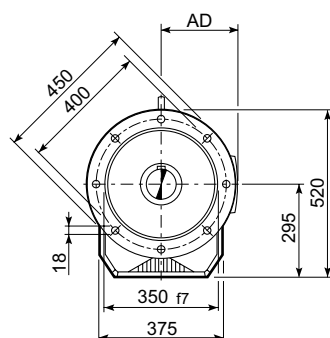
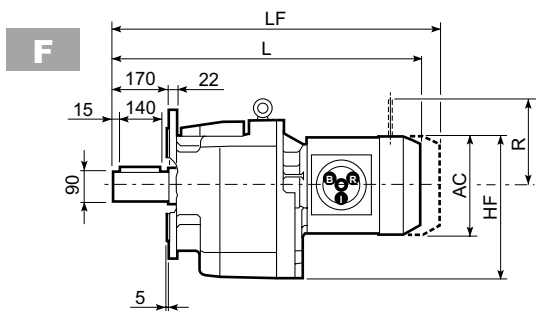
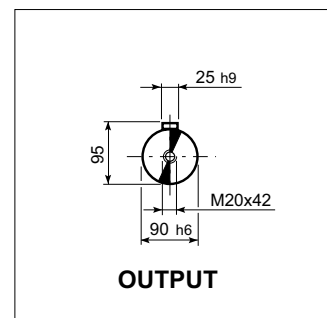
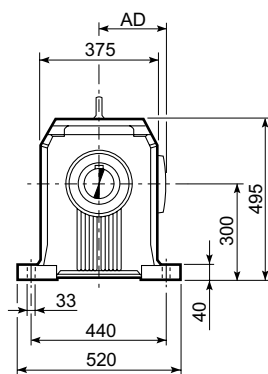
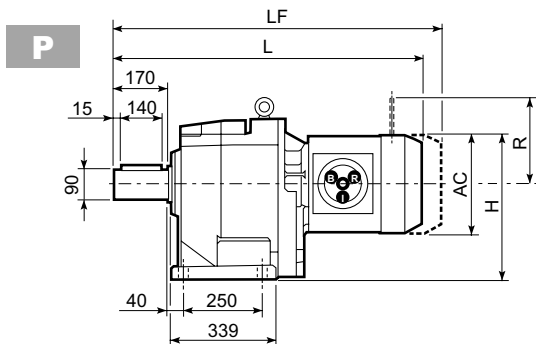

C 90															
										M...FD		M...FD		M...FA	
			AC	H	HF	L	AD		LF		R	AD	R	AD	
C 90 2/3	S3	M3S	195	397.5	392.5	852	142	228	948	236	160	155	160	142	
C 90 2/3	S3	M3L	195	397.5	392.5	884	142	236	975	243	160	155	160	142	
C 90 2/3	S4	M4	258	429	424	992	193	270	1101	288	226	193	217	193	
C 90 2/3	S4	M4LC	258	429	424	1027	193	278	1126	296	226	193	217	193	
C 90 2/3	S5	M5S	310	455	450	1078.5	245	298	1218.5	328	266	245	247	245	
C 90 2/3	S5	M5L	310	455	450	1122.5	245	314	1262.5	344	266	245	247	245	
C 90 4	S2	M2S	156	378	373	891	119	234	962	238	129	143	134	119	
C 90 4	S3	M3S	195	397.5	392.5	935	142	239	1031	246	160	155	160	142	
C 90 4	S3	M3L	195	397.5	392.5	967	142	246	1058	253	160	155	160	142	
C 90 4	S4	M4	258	429	424	1075	193	280	1184	298	226	193	217	193	

# C 90...P(IEC)

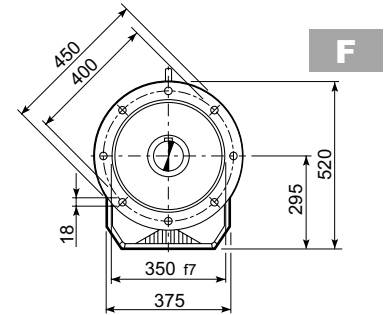
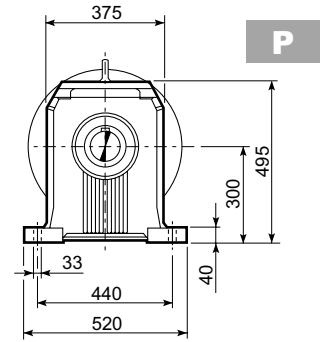
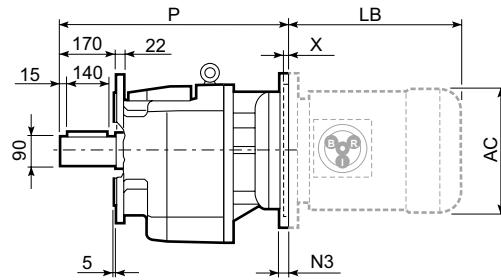
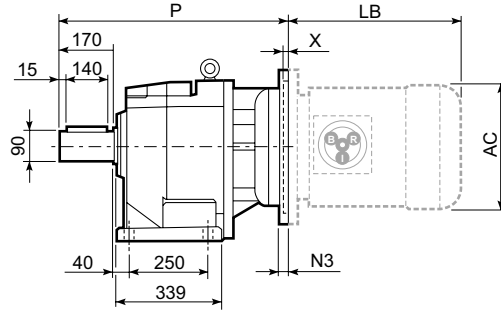
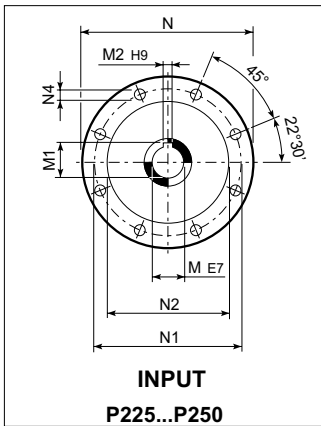
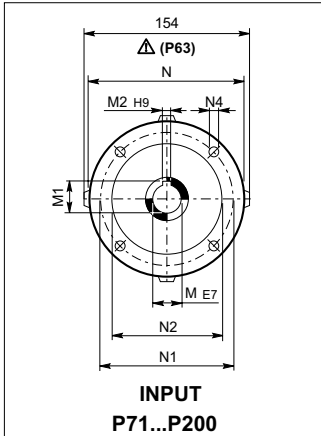
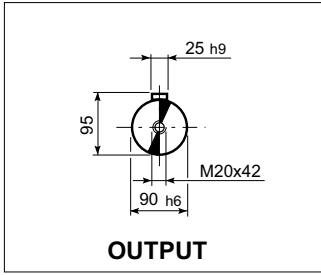
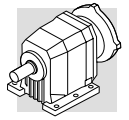

C 90													BN...		BN...FD BN...FA		
M	M1	M2	N	N1	N2	N3	N4	X	P	kg	IEC	LB	AC	LB	AC		
C 90 2/3	P80	19	21.8	6	200	165	130	—	M10x12	4	644.5	229	BN 80	234	156	306	156
C 90 2/3	P90	24	27.3	8	200	165	130	—	M10x12	4	644.5	229	BN 90	276	176	359	176
C 90 2/3	P100	28	31.3	8	250	215	180	—	M12x16	4.5	654.5	234	BN 100	307	195	398	195
C 90 2/3	P112	28	31.3	8	250	215	180	—	M12x16	4.5	654.5	234	BN 112	325	219	424	219
C 90 2/3	P132	38	41.3	10	300	265	230	16	14	5	691	236	BN 132	413	258	523	258
C 90 2/3	P160	42	45.3	12	350	300	250	23	18	6	746.5	251	BN 160MR	452	258	562	258
													BN 160M/L	486	310	626	310
													BN 180M	530	310	670	310
C 90 2/3	P180	48	51.8	14	350	300	250	23	18	6	746.5	251	BN 180L	598	348	756	348
													BN 200L	612	348	768	348
C 90 2/3	P200	55	59.3	16	400	350	300	—	M16x25	7	771.5	272	BN 200L	612	348	768	348
C 90 2/3	P225	60	64.4	18	450	400	350	30	18	6	817	273	BN 225	—	—	—	—
C 90 2/3	P250	65	69.4	18	550	500	450	30	18	6	847	295	BN 250	—	—	—	—
C 90 4	P71	14	16.3	5	160	130	110	—	M8x16	4.5	707.5	236	BN 71	219	138	280	138
C 90 4	P80	19	21.8	6	200	165	130	—	M10x12	4	727	238	BN 80	234	156	306	156
C 90 4	P90	24	27.3	8	200	165	130	—	M10x12	4	727	238	BN 90	276	176	359	176
C 90 4	P100	28	31.3	8	250	215	180	—	M12x16	4.5	737	242	BN 100	307	195	398	195
C 90 4	P112	28	31.3	8	250	215	180	—	M12x16	4.5	737	242	BN 112	325	219	424	219
C 90 4	P132	38	41.3	10	300	265	230	16	14	5	773.5	244	BN 132	413	258	523	258
C 90 4	P160	42	45.3	12	350	300	250	23	18	5.5	824	248	BN 160MR	452	258	562	258
													BN 160M/L	486	310	626	310
													BN 180M	530	310	670	310
C 90 4	P180	48	51.8	14	350	300	250	23	18	5.5	824	248	BN 180M	530	310	670	310
													BN 180L	598	348	756	348

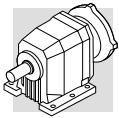

# C 90...HS

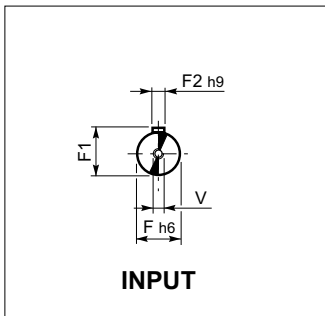
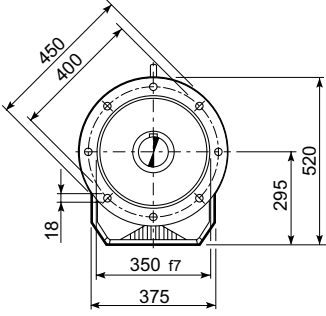
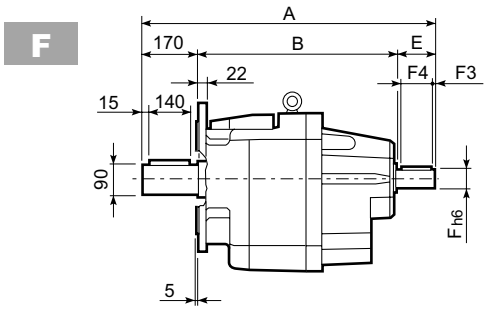
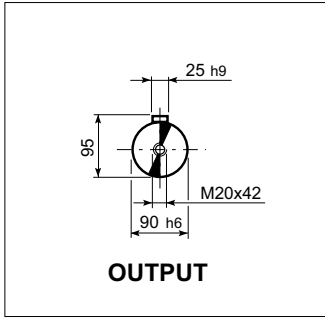
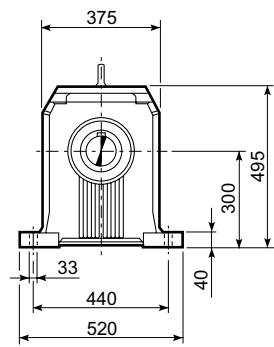
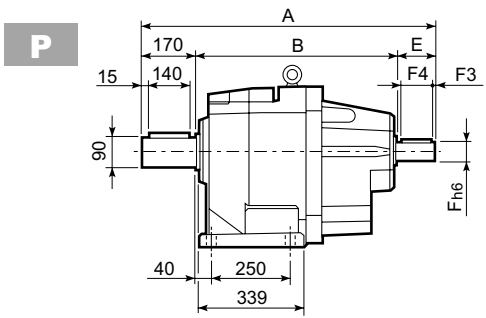

C 90											
		A	B	E	F	F1	F2	F3	F4	V	kg
	HS	930.5	620.5	140	60	64	18	10	120	M16x36	273
		930.5	620.5	140	60	64	18	10	120	M16x36	273
		797	577	50	24	27	8	2.5	45	M8x19	240

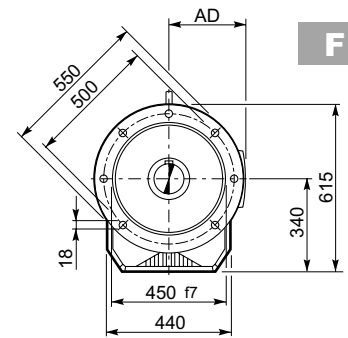
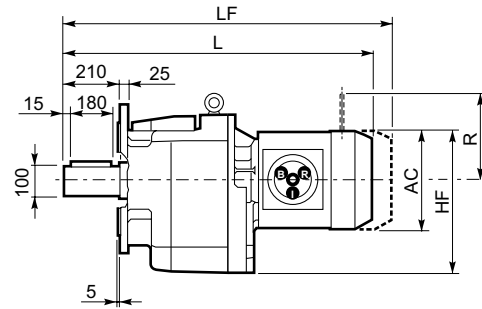
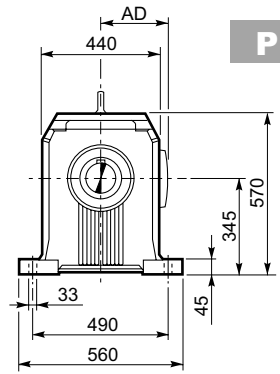
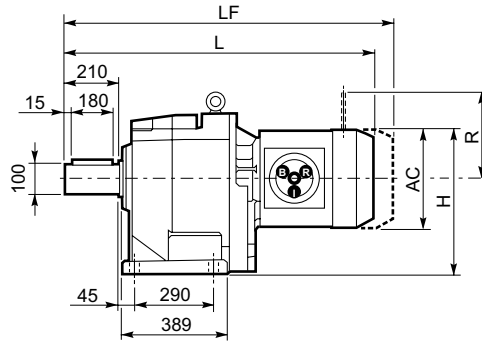
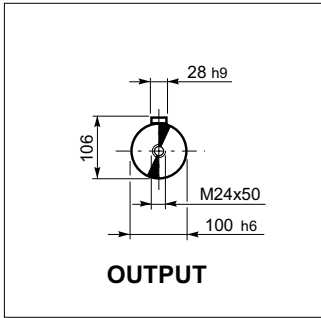
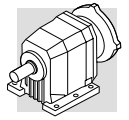

C 100															
										M...FD M...FA		M...FD		M...FA	
			AC	H	HF	L	AD		LF		R	AD	R	AD	
C 100 2/3	S4	M4	258	474	469	1087	193	392	1196	410	226	193	217	193	
C 100 2/3	S4	M4LC	258	474	469	1122	193	400	1221	418	226	193	217	193	
C 100 2/3	S5	M5S	310	500	495	1173.5	245	420	1313.5	450	266	245	247	245	
C 100 2/3	S5	M5L	310	500	495	1217.5	245	436	1357.5	466	266	245	247	245	
C 100 4	S2	M2S	156	423	418	985.5	119	354	1056.5	357	129	143	134	119	
C 100 4	S3	M3S	195	442.5	437.5	1029.5	142	358	1125.5	366	160	155	160	142	
C 100 4	S3	M3L	195	442.5	437.5	1061.5	142	366	1152.5	373	160	155	160	142	
C 100 4	S4	M4	258	474	469	1169.5	193	400	1278.5	418	226	193	217	193	
C 100 4	S4	M4LC	258	474	469	1204.5	245	408	1303.5	426	226	193	217	193	

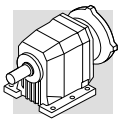

# C 100...P(IEC)

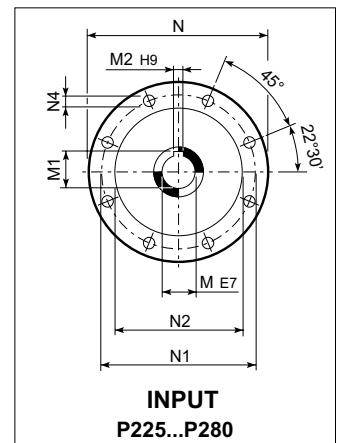
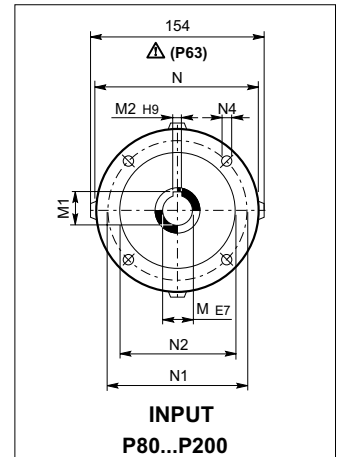
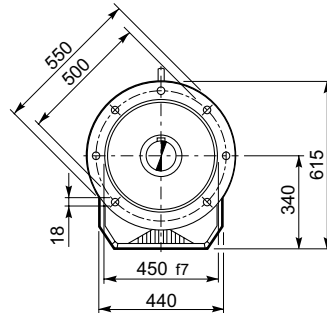
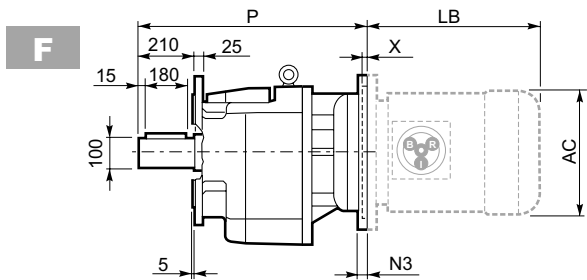
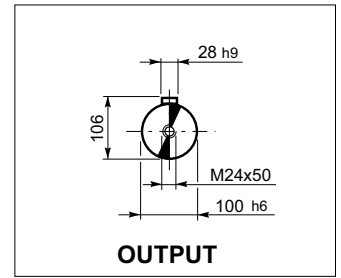
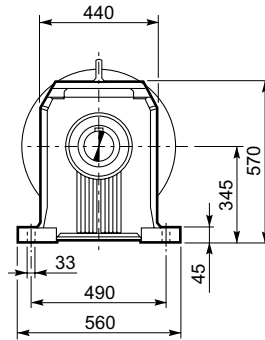
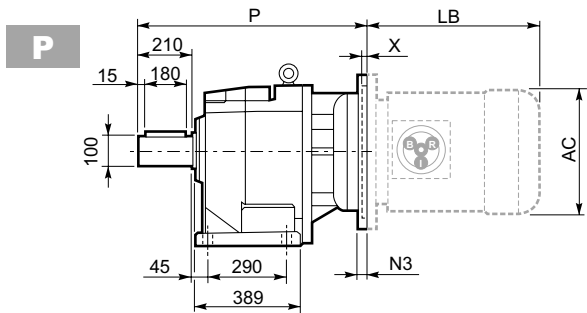

C 100													BN...		BN...FD BN...FA		
		M	M1	M2	N	N1	N2	N3	N4	X	P		LB	AC	LB	AC	
C 100 2/3	P100	28	31.3	8	250	215	180	—	M12x16	4.5	749.5	364	BN 100	307	195	398	195
C 100 2/3	P112	28	31.3	8	250	215	180	—	M12x16	4.5	749.5	364	BN 112	325	219	424	219
C 100 2/3	P132	38	41.3	10	300	265	230	16	14	5	786	367	BN 132	413	258	523	258
C 100 2/3	P160	42	45.3	12	350	300	250	23	18	6	841.5	382	BN 160MR	452	258	562	258
													BN 160M/L	486	310	626	310
													BN 180M	530	310	670	310
C 100 2/3	P180	48	51.8	14	350	300	250	23	18	6	841.5	382	BN 180L	598	348	756	348
													BN 200L	612	348	768	348
C 100 2/3	P200	55	59.3	16	400	350	300	—	M16x25	7	866.5	403	BN 225	—	—	—	—
C 100 2/3	P225	60	64.4	18	450	400	350	30	18	7	912	403	BN 250	—	—	—	—
C 100 2/3	P250	65	69.4	18	550	500	450	30	18	7	942	426	BN 280	—	—	—	—
C 100 2/3	P280	75	79.9	20	550	500	450	30	18	6	942	426	BN 80	234	156	306	156
C 100 4	P80	19	21.8	6	200	165	130	—	M10x12	4	822.5	371	BN 90	276	176	359	176
C 100 4	P90	24	27.3	8	200	165	130	—	M10x12	4	822.5	371	BN 100	307	195	398	195
C 100 4	P100	28	31.3	8	250	215	180	—	M12x16	4.5	832.5	375	BN 112	325	219	424	219
C 100 4	P112	28	31.3	8	250	215	180	—	M12x16	4.5	832.5	375	BN 132	413	258	523	258
C 100 4	P132	38	41.3	10	300	265	230	16	14	5	869	377	BN 160MR	452	258	562	258
C 100 4	P160	42	45.3	12	350	300	250	23	18	5.5	919.5	381	BN 160M/L	486	310	626	310
													BN 180M	530	310	670	310
C 100 4	P180	48	51.8	14	350	300	250	23	18	5.5	919.5	381	BN 180L	598	348	756	348

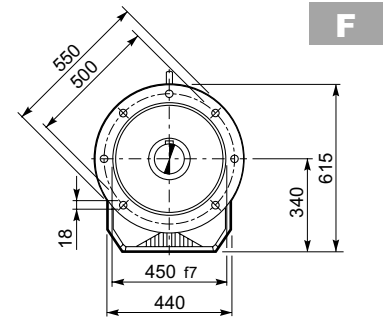
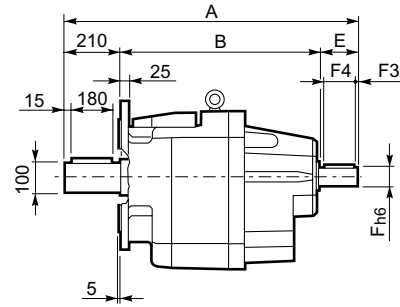
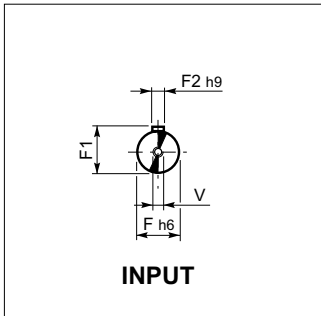
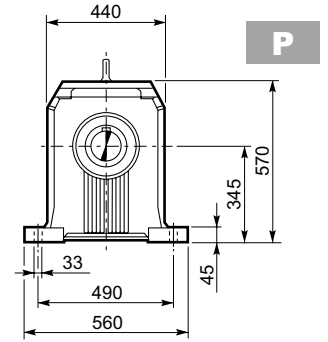
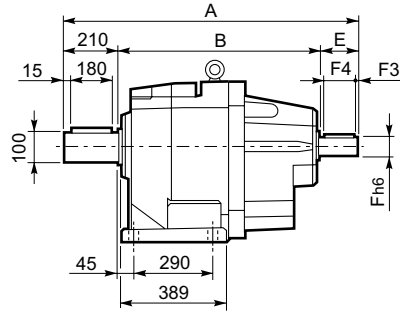
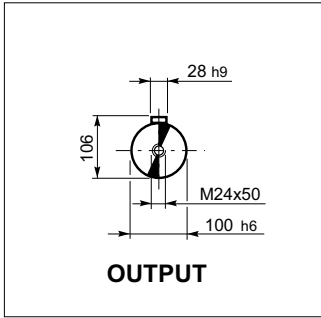
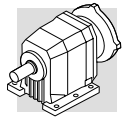

C 100											
		A	B	E	F	F1	F2	F3	F4	V	kg
		1025.5	676	140	60	64	18	10	120	M16x36	409
<b>C 100 2</b>	<b>HS</b>	1025.5	676	140	60	64	18	10	120	M16x36	409
<b>C 100 3</b>		892	632	50	24	27	8	2.5	45	M8x19	372
<b>C 100 4</b>											

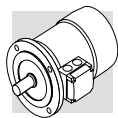

**MOTORI ELETTRICI**
**ELECTRIC MOTORS**
**ELEKTROMOTOREN**
**MOTEURS  
ELECTRIQUES**
**M1 - SIMBOLOGIA E  
UNITÀ DI MISURA**
**M1 - SYMBOLS AND UNITS  
OF MEASUREMENT**
**M1 - SYMBOLE UND  
MAßEINHEITEN**
**M1 - SYMBOLES ET UNITES  
DE MESURE**

Simb. Symb.	U.m. Einheit	Descrizione	Description	Beschreibung	Description
$\cos\varphi$	–	Fattore di potenza	Power factor	Leistungsfaktor	Facteur de puissance
$\eta$	–	Rendimento	Efficiency	Wirkungsgrad	Rendement
$f_m$	–	Fattore correttivo della potenza	Power adjusting factor	Leistungskorrekturfaktor	Facteur de correction de la puissance
$I$	–	Rapporto di intermittenza	Cyclic duration factor	Relative Einschaltdauer	Rapport d'intermittence
$I_N$	[A]	Corrente nominale	Rated current	Nennstrom	Courant nominal
$I_S$	[A]	Corrente di spunto	Locked rotor current	Kurzschlußstrom	Courant de démarrage
$J_C$	[Kgm <sup>2</sup> ]	Momento di inerzia del carico	Load moment of inertia	Massenträgheitsmoment der externen Massen	Moment d'inertie de la charge
$J_M$	[Kgm <sup>2</sup> ]	Momento di inerzia motore	Moment of inertia	Trägheitsmoment	Moment d'inertie du moteur
$K_C$	–	Fattore di coppia	Torque factor	Drehmomentfaktor	Facteur de couple
$K_d$	–	Fattore di carico	Load factor	Lastfaktor	Facteur de charge
$K_J$	–	Fattore di inerzia	Inertia factor	Trägheitsfaktor	Facteur d'inertie
$M_A$	[Nm]	Coppia accelerante media	Mean breakaway torque	Losbrechmoment	Couple d'accélération moyen
$M_B$	[Nm]	Coppia frenante	Brake torque	Bremsemoment	Couple du frein
$M_N$	[Nm]	Coppia nominale	Rated torque	Nennmoment	Couple nominal
$M_L$	[Nm]	Coppia resistente media	Counter-torque during acceleration	Lastmoment	Couple résistant moyen
$M_S$	[Nm]	Coppia di spunto	Starting torque	Startmoment	Couple de démarrage
$n$	[min <sup>-1</sup> ]	Velocità nominale	Rated speed	Nennzahl	Vitesse nominale
$P_B$	[W]	Potenza assorbita dal freno a 20°C	Power drawn by the brake at 20°C	Leistungsaufnahme der Bremse bei 20°C	Puissance absorbée par le frein à 20°C
$P_n$	[kW]	Potenza nominale	Motor rated power	Nennleistung	Puissance nominale
$P_r$	[kW]	Potenza richiesta	Required power	Benötigte Leistung	Puissance nécessaire
$t_1$	[ms]	Ritardo di sblocco del freno con alimentatore a semionda	Brake response time with one-way rectifier	Ansprechzeit Bremse mit Einweg-Gleichrichter	Temps de déblocage du frein avec alimentation à demi-onde
$t_{1s}$	[ms]	Tempo di sblocco del freno con alimentatore a controllo elettronico	Brake response time with electronic-controlled rectifier	Ansprechzeit Bremse mit elektronisch gesteuertem Gleichrichter	Temps de déblocage du frein avec alimentation à contrôle électronique
$t_2$	[ms]	Ritardo di frenatura con disgiunzione lato c.a.	Brake reaction time with a.c. disconnect	Einfallzeit Bremse bei Unterbrechung der Stromversorgung WS	Retard de freinage avec coupure coté c.a.
$t_{2c}$	[ms]	Ritardo di frenatura con disgiunzione circuito c.a. e c.c.	Brake reaction time with a.c. and d.c. disconnect	Einfallzeit Bremse bei Unterbrechung der Stromversorgung WS und GS	Retard de freinage avec coupure coté c.a. et c.c.
$t_a$	[°C]	Temperatura ambiente	Ambient temperature	Umgebungstemperatur	Température ambiante
$t_f$	[min]	Tempo di funzionamento a carico costante	Work time at constant load	Betriebsdauer unter Nennbelastung	Temps de fonctionnement à charge constante
$t_r$	[min]	Tempo di riposo	Rest time	Aussetzzeit	Temps de repos
$W$	[J]	Lavoro di frenatura accumulato tra due regolazioni del traferro	Braking work between service interval	Bremsenergie zwischen zwei Einstellungen	Energie de freinage accumulée entre deux réglages de l'entrefer
$W_{max}$	[J]	Energia massima per singola frenatura	Maximum brake work for each braking	Max. Bremsarbeit pro Bremsvorgang	Energie maxi par freinage
$Z$	[1/h]	N° di avviamenti ammissibili, a carico	Permissible starting frequency, loaded	Schalzhäufigkeit Nennbetrieb	Nombre de démarrages admissibles en charge
$Z_0$	[1/h]	N° di avviamenti ammissibili a vuoto (I = 50%)	Max. permissible unloaded starting frequency (I = 50%)	Max. Schalzhäufigkeit im Leerlauf (relative Einschalt-dauer I = 50%)	Nombre de démarrages admissible à vide (I = 50%)

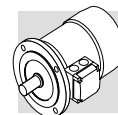

## M2 - CARATTERISTICHE GENERALI

### Programma di produzione

I motori elettrici asincroni trifase del programma di produzione della BONFIGLIOLI RIDUTTORI sono previsti nelle forme costruttive base IMB5, IMB14 e loro derivate con le seguenti polarità: 2, 4, 6, 2/4, 2/6, 2/8, 2/12. Nel presente catalogo sono evidenziate inoltre, le caratteristiche tecniche dei motori in versione integrata, tipo M.

### Normative

I motori descritti in questo catalogo sono costruiti in accordo alle Norme ed unificazioni applicabili evidenziate nella tabella seguente.

## M2 - GENERAL CHARACTERISTICS

### Production range

*The asynchronous three-phase electric motors of BONFIGLIOLI RIDUTTORI's production, are available in basic designs IMB5 and IMB14 and derived versions, with the following polarities: 2, 4, 6, 2/4, 2/6, 2/8, 2/12. The technical characteristics of compact motors, M type, are also supplied in this manual.*

### Standards

*The motors described in this catalogue are manufactured to the applicable standards shown in the following table.*

## M2 - ALLGEMEINE EIGENSCHAFTEN

### Produktprogramm

Die Dreiphasen-Asynchronmotoren aus dem Produktprogramm von BONFIGLIOLI RIDUTTORI gibt es in den Grundbauformen IMB5, IMB14 und deren Ableitungen mit folgenden Polzahlen: 2, 4, 6, 2/4, 2/6, 2/8 und 2/12. Im vorliegenden Katalog sind außerdem die technischen Eigenschaften der Motoren in Kompaktausführung hervorgehoben.

### Normen

Die in diesem Katalog beschriebenen Motoren sind in Übereinstimmung mit den in der folgenden Tabelle angegebenen einschlägigen Normen und Vereinheitlichungsrichtlinien konstruiert worden.

## M2 - CARACTERISTIQUES GENERALES

### Programme de production

*Les moteurs électriques asynchrones triphasés du programme de production de BONFIGLIOLI RIDUTTORI sont prévus dans les formes de construction de base IMB5, IMB14 et leur dérivés avec les polarités suivantes: 2, 4, 6, 2/4, 2/6, 2/8, 2/12. Dans le présent catalogue sont également mises en évidence les caractéristiques techniques des moteurs en version compacte, type M.*

### Réglementations

*Les moteurs décrits dans ce catalogue sont construits en accord avec les Normes et standardisations applicables mises en évidence dans le tableau ci-dessous.*

(A26)

Titolo / Title / Titel / Titre	CEI	IEC
Prescrizioni generali per macchine elettriche rotanti <i>General requirements for rotating electrical machines</i> Allgemeine Vorschriften für umlaufende elektrische Maschinen <i>Prescriptions générales pour machines électriques tournantes</i>	CEI EN 60034-1	IEC 60034-1
Marcatura dei terminali e senso di rotazione per macchine elettriche rotanti <i>Terminal markings and direction of rotation of rotating machines</i> Kennzeichnung der Anschlußklemmen und Drehrichtung von umlaufenden elektrischen Maschinen <i>Définitions des bornes et sens de rotation pour machines électriques tournantes</i>	CEI 2-8	IEC 60034-8
Metodi di raffreddamento delle macchine elettriche <i>Methods of cooling for electrical machines</i> Verfahren zur Kühlung von elektrischen Maschinen <i>Méthodes de refroidissement des machines électriques</i>	CEI EN 60034-6	IEC 60034-6
Dimensioni e potenze nominali per macchine elettriche rotanti <i>Dimensions and output ratings for rotating electrical machines</i> Auslegung der Nennleistung von umlaufenden elektrischen Maschinen <i>Dimensions, puissances nominales pour machines électriques tournantes</i>	EN 50347	IEC 60072
Classificazione dei gradi di protezione delle macchine elettriche rotanti <i>Classification of degree of protection by enclosures for rotating machines</i> Klassifizierung der Schutzart von umlaufenden elektrischen Maschinen <i>Classification des degrés de protection des machines électriques tournantes</i>	CEI EN 60034-5	IEC 60034-5
Limiti di rumorosità <i>Noise limits</i> Geräuschgrenzwerte <i>Limites de bruit</i>	CEI EN 60034-9	IEC 60034-9
Sigle di designazione delle forme costruttive e dei tipi di installazione <i>Classification of type of construction and mounting arrangements</i> Abkürzungen zur Kennzeichnung der Bauform und der Einbaulagen <i>Sigles de dénomination des formes de construction et des types d'installation</i>	CEI EN 60034-7	IEC 60034-7
Tensione nominale per i sistemi di distribuzione pubblica dell'energia elettrica a bassa tensione <i>Rated voltage for low voltage mains power</i> Nennspannung für öffentliche NS-Stromverteilungssysteme <i>Tension nominale pour les systèmes de distribution publique de l'énergie électrique en basse tension</i>	CEI 8-6	IEC 60038
Grado di vibrazione delle macchine elettriche <i>Vibration level of electric machines</i> Schwingstärke bei elektrischen Maschinen <i>Degré de vibration des machines électriques</i>	CEI EN 60034-14	IEC 60034-14

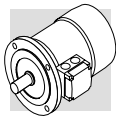

I motori corrispondono inoltre alle Norme straniere adeguate alle IEC 60034-1 e qui riportate.

The motors also comply with foreign standards adapted to IEC 60034-1 as shown here below.

Die Motoren entsprechen außerdem den an die IEC-Norm 60034-1 angepaßten ausländischen Normen, die in der folgenden Tabelle genannt werden.

En outre, les moteurs correspondent aux Normes étrangères adaptées aux IEC 60034-1 indiquées dans le tableau ci-dessous.

(A27)

DIN VDE 0530	Germania	Germany	Deutschland	Allemagne
BS5000 / BS4999	Gran Bretagna	Great Britain	Großbritannien	Grande Bretagne
AS 1359	Australia	Australia	Australien	Australie
NBNC 51 - 101	Belgio	Belgium	Belgien	Belgique
NEK - IEC 34	Norvegia	Norway	Norwegen	Norvège
NF C 51	Francia	France	Frankreich	France
OEVE M 10	Austria	Austria	Österreich	Autriche
SEV 3009	Svizzera	Switzerland	Schweiz	Suisse
NEN 3173	Paesi Bassi	Netherlands	Niederlande	Pays Bas
SS 426 01 01	Svezia	Sweden	Schweden	Suède

## CUS

### MOTORI PER USA E CANADA

### MOTORS FOR USA AND CANADA

### MOTOREN FÜR DIE USA UND KANADA

### MOTEURS POUR ETATS-UNIS ET CANADA

I motori BN ed M sono disponibili in esecuzione NEMA Design C (per le caratteristiche elettriche), certificata in conformità alle norme CSA (Canadian Standard) C22.2 N° 100 e UL (Underwriters Laboratory) UL 1004 con targhetta riportante il marchio cCSAus (tensione ≤ 600V), specificare in questo caso l'opzione CUS.

Le tensioni delle reti di distribuzione americane e le corrispondenti tensioni nominali da specificare per il motore sono indicate nella tabella seguente:

BN and M motors are available in NEMA Design C configuration (concerning electrical characteristics), certified to CSA (Canadian standard) C22.2 No. 100 and UL (Underwriters Laboratory) UL 1004. Name plate includes the cCSAus mark (voltage ≤ 600V), in this case, please specify CUS option.

US power mains voltages and the corresponding rated voltages to be specified for the motor are indicated in the following table:

Die BN/M-Motoren sind in der Ausführung NEMA, Design C (aufgrund der elektrischen Eigenschaften), den Normen CSA (Canadian Standard) C22.2 Nr 100 und UL (Underwriters Laboratory) UL 1004 gemäß zertifiziert, mit einem Typenschild mit cCSAus Zeichen (Spannung ≤ 600V), in diesem Fall muss die Option CUS angegeben werden. Die Spannungen der amerikanischen Verteilernetze und die entsprechenden tens-Nennspannungen, die bei den Motoren angegeben werden müssen, können der folgenden Tabelle entnommen werden:

Les moteurs BN et M sont disponibles en exécution NEMA Design C (pour les caractéristiques électriques), certifiée conforme aux normes CSA (Canadian Standard) C22.2 N°100 et UL (Underwriters Laboratory) UL 1004 avec plaque signalétique indiquant la marque cCSAus (tension ≤ 600V), dans ce cas, spécifier l'option CUS.

Les tensions des réseaux de distribution américains ainsi que les tensions nominales à spécifier pour le moteur sont indiquées dans le tableau suivant :

(A28)

Frequenza / Frequency Frequenz / Fréquence	Tensione di rete / Mains voltage Netzspannung / Tension de réseau	V <sub>mot</sub>
60 Hz	208 V	200 V
	240 V	230 V
	480 V	460 V
	600 V	575 V

I motori dotati di collegamento YYY (es. 230/460-60; 220/440-60) presentano di serie una morsettiera a 9 terminali.

Per le stesse esecuzioni, e inoltre per l'alimentazione 575V-60Hz, la potenza di targa corrisponde a quella normalizzata a 50Hz.

Per i motori autofrenanti con freno in c.c. tipo BN\_FD l'alimentazione del raddrizzatore è da morsettiera motore con tensione 230V a.c. monofase.

Per i motori autofrenanti l'alimentazione del freno è così predisposta:

Motors with YY/Y connection (e.g. 230/460-60; 220/440-60) feature, as standard, a 9-stud terminal board. For same executions, as well as for 575V-60Hz supply, the nominal rating is coincident with the correspondent 50Hz rating.

For DC brake motors type BN\_FD, the rectifier is connected to a single-phase 230 VAC supply voltage in the motor terminal box.

Brake power supply for brake motors is as follows:

Motoren mit YY/Y-Anschluss (z.B. 230/460-60; 220/440-60) sind standardmäßig mit 9 Pins auf dem Klemmbrett ausgeführt. Für gleiche Ausführungen, ebenso wie für 575V-60Hz, die Nennleistung ist gleich mit der entsprechenden 50 Hz-Leistung. Für Bremsmotoren mit Gleichstrombremse vom Typ BN\_FD erfolgt die Versorgung des Gleichrichters über den Motorklemmenkasten mit einer Spannung von 230V (einphasiger Wechselstrom). Bei Bremsmotoren stellt sich die Versorgung der Bremse wie folgt dar:

Les moteurs avec connexion YYY (ex. 230/460-60; 220/440-60) présentent, en standard, une plaque à borne avec 9 bornes. Pour les memes executions, et aussi pour l'alimentation 575V-60Hz, la puissance de plaque correspond à celle normalisée à 50Hz.

Pour les moteurs frein avec frein en c.c. type BN\_FD, l'alimentation du redresseur provient de la boîte à bornes moteur avec une tension 230V c.a. monophasée. Pour les moteurs frein l'alimentation du frein est la suivante :

BN_FD M_FD	BN_FA ; BN_BA M_FA	Specificare / Specify Bitte angeben / Spécifier
Da morsettiera motore 1~230V c.a. Wired to terminal box 1~230V a.c. Vom Motorklemmenkasten 1~230V W.S. Depuis boîte à bornes moteur 1~230V c.a.	Alimentazione separata / Separate power supply Fremdversorgung / Alimentation séparée 230V Δ - 60Hz	230SA
	Alimentazione separata / Separate power supply Fremdversorgung / Alimentation séparée 460V Y - 60Hz	460SA

L'opzione CUS non è applicabile ai motori dotati di servoventilazione.

The option CUS does not apply to servo-ventilated motors.

Die CUS-Option ist für die Fremdlüftermotoren nicht anwendbar.

L'option CUS n'est pas applicable aux moteurs doués de ventilation forcée.

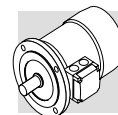

### Direttive CEE 73/23 (LVD) e CEE 89/336 (EMC)

I motori delle serie BN ed M sono conformi ai requisiti delle Direttive CEE 73/23 (Direttiva Bassa Tensione) e CEE 89/336 (Direttiva Compatibilità Elettromagnetica), e riportano in targa la marcatura CE.

Per quanto riguarda la Direttiva EMC, la costruzione è in accordo alle Norme CEI EN 60034-1 sez. 12, EN 50081, EN 50082.

I motori con freno in c.c. tipo FD, se corredati dell'opportuno filtro capacitivo in ingresso al raddrizzatore (opzione CF), rientrano nei limiti di emissione previsti dalla Norma EN 50081-1 "Compatibilità elettromagnetica - Norma Generica sull'emissione - Parte 1: Ambienti residenziali, commerciali e dell'industria leggera". I motori soddisfano inoltre le prescrizioni della Norma CEI EN 60204-1 "Equipaggiamento elettrico delle macchine".

È responsabilità del costruttore o dell'assemblatore dell'apparecchiatura che incorpora i motori come componenti garantire la sicurezza e la conformità alle direttive del prodotto finale.

### Directives 73/23/EEC (LVD) and 89/336/EEC (EMC)

*BN motors meet the requirements of Directives 73/23/EEC (Low Voltage Directive) and 89/336/EEC (Electromagnetic Compatibility Directive) and their name plates bear the CE mark.*

*As for the EMC Directive, construction is in accordance with standards CEI EN 60034-1 Sect. 12, EN 50081, EN 50082.*

*Motors with FD brakes, when fitted with the suitable capacitive filter at rectifier input (option CF), meet the emission limits required by Standard EN 50081-1 "Electromagnetic compatibility - Generic Emission Standard - Part 1: Residential, commercial and light industrial environment". Motors also meet the requirements of standard CEI EN 60204-1 "Electrical equipment of machines".*

*The responsibility for final product safety and compliance with applicable directives rests with the manufacturer or the assembler who incorporate the motors as component parts.*

### Richtlinien EWG 73/23 (LVD) und EWG 89/336 (EMC)

Die Motoren der Serie BN entsprechen den Anforderungen der Richtlinien EWG 73/23 (Richtlinie - Niederspannung) und CEE 89/336 (Richtlinie - elektromagnetische Kompatibilität) und sind mit dem CE-Zeichen ausgestattet.

Im Hinblick auf die Richtlinie EMC entspricht die Konstruktion den Normen CEI EN 60034-1, Abschn. 12, EN 50081, EN 50082.

Die Motoren mit dem Bremstyp FD fallen, falls mit dem entsprechenden kapazitiven Filter am Eingang des Gleichrichters ausgestattet (Option CF), unter die Emissionsgrenzwerte, die von der Norm EN 50081-1 "Elektromagnetische Kompatibilität - Allgemeine Norm für Emissionen - Teil 1: Wohngebiete, Handels- und Leichtindustriestrukturen" vorgesehen werden. Die Motoren entsprechen darüber hinaus den von der Norm CEI EN 60204-1 "Elektrische Maschinenausrüstung" gegebenen Vorschriften.

Es liegt in der Verantwortung des Herstellers oder es Monteurs der Ausrüstung, in der die Motoren als Komponenten montiert werden, die Sicherheit und die Übereinstimmung mit den Richtlinien des Endprodukts zu gewährleisten.

### Directives CEE 73/23 (LVD) et CEE 89/336 (EMC)

*Les moteurs de la série BN sont conformes aux conditions requises par les Directives CEE 73/23 (Directive Basse Tension) et CEE 89/336 (Directive Compatibilité Electromagnétique), et le marquage CE est indiqué sur la plaque signalétique.*

*En ce qui concerne la Directive EMC, la fabrication répond aux Normes CEI EN 60034-1 Sect. 12, EN 50081, EN 50082.*

*Les moteurs avec frein FD, s'ils sont équipés du frein capacitif approprié en entrée du redresseur (option CF), rentrent dans les limites d'émission prévues par la Norme EN 50081-1 "Compatibilité électromagnétique - Norme Générique sur l'émission - Partie 1 : Milieux résidentiels, commerciaux et de l'industrie légère". Les moteurs répondent aussi aux prescriptions de la Norme CEI EN 60204-1 "Équipement électrique des machines".*

*Le fabricant ou le monteur de la machine qui comprend les moteurs comme composant est responsable et doit se charger de garantir la sécurité et la conformité aux directives du produit final.*

### Rendimento - Accordo CEMEP

Con l'obiettivo di ridurre significativamente il consumo europeo di energia elettrica mediante la sensibilizzazione degli utenti all'uso di motori maggiormente efficienti, la Commissione Europea per l'Energia e il CEMEP hanno concordato le condizioni ricorrenti per la classificazione dei motori elettrici in classi di rendimento denominate, in senso decrescente, **eff1**, **eff2** ed **eff3**.

Oggetto di questo accordo sono solamente i motori trifase standard in c.a. a 2 e 4 poli, costruzione chiusa con rotore a gabbia di scoiattolo, ventilazione esterna e potenza all'albero compresa fra 1,1 e 90 kW, alimentazione a 400V - 50 Hz in servizio continuo S1.

È facoltà dei costruttori di motori elettrici decidere di classificare volontariamente i propri prodotti in una delle tre classi di rendimento sopra citate. In questo caso essi devono apporre sulla targa il marchio relativo alla classe di rendimento applicabile ed inserire, fra i dati tecnici, i valori di rendimento a pieno carico ed a ¾ del carico nominale.

I motori Bonfiglioli ricompresi nell'oggetto di questo accordo sono conformi alla classe di rendimento **eff2** e sono pertanto chiaramente identificati in targa tramite il logo sotto riportato:

### Efficiency - the CEMEP agreement

*CEMEP, the European Committee of Manufacturers of Electrical Machines and Power Electronics hopes to reduce electrical energy consumption in Europe by informing users of the efficiency of electrical motors. As a contribution in this direction, CEMEP has recently published an agreement stating the specifications for electric motor energy efficiency classes **eff1**, **eff2** and **eff3** (listed in order of decreasing efficiency).*

*The CEMEP agreement covers only standard, 2 and 4 pole, three phase, AC motors, of closed rotor and squirrel cage construction, with external ventilation and rated power at the output shaft of 1.1 to 90 kW, for use with a 400V - 50 Hz power supply under S1 continuous duty conditions.*

*It is left up to individual electric motor manufacturers to classify their products in one of the three above classes. If they decide to do so, they must apply the relevant efficiency mark to the motor and include, together with all the other relevant technical specifications, the measured efficiency figures for full rated load and ¾ rated load.*

*Under the terms of this agreement, Bonfiglioli's electric motors conform to efficiency class **eff2** and are clearly identified as such by the following mark on the data plate:*

### Wirkungsgrad - die CEMEP Vereinbarung

CEMEP, der europäische Herstellerverband von elektrischen Maschinen und Leistungs-Elektronik hofft, den elektrischen Energieverbrauch in Europa, durch Informationen über die Wirkungsgrade von elektrischen Motoren an die Benutzer, zu reduzieren. Als Beitrag in dieser Richtung, hat die CEMEP vor kurzem eine Vereinbarung veröffentlicht, die die Energie-Effizienz-Klassen **eff1**, **eff2** und **eff3** für Elektromotoren spezifiziert. (Aufgelistet nach abnehmendem Wirkungsgrad).

Die CEMEP Vereinbarung beinhaltet nur 2 und 4 polige Drehstrommotoren mit geschlossenem Rotor als Kurzschlussläufer, integriertem Lüfter, Nennleistungen an der Abtriebswelle von 1.1 - 90 kW, mit einer Energieversorgung von 400V - 50Hz und der Betriebsart S1 (Dauerbetrieb).

Es bleibt den einzelnen Elektromotoren Herstellern überlassen, ihre Produkte nach einer der drei oben benannten Effizienz-Klassen zu klassifizieren. Wenn sie sich dazu entscheiden, müssen sie die relevante Markierung auf dem Motor anbringen und zusammen mit allen anderen relevanten technischen Einzelheiten, die gemessenen Wirkungsgradangaben bei Voll- und Dreiviertellast ausweisen. Unter den Bedingungen dieser Vereinbarung entsprechen die elektrischen Motoren von Bonfiglioli der Effizienz-Klasse **eff2** und werden als solche durch die folgende Markierung auf dem Typenschild deutlich gekennzeichnet:

### Rendement - L'accord CEMEP

*La Commission Européenne sur l'Energie et le CEMEP (European Committee of Manufacturers of Electrical Machines and Power Electronics), espère réduire de façon sensible la consommation européenne d'énergie électrique à travers l'information sur l'efficacité des moteurs électriques. Pour ce faire, ils ont fixé une classification des moteurs électriques en « classes de rendement » appelée, en sens décroissant d'efficacité : **eff1**, **eff2** et **eff3**.*

*Font partie de cet accord seulement les moteurs triphasés standard en c.a. à 2 et 4 pôles, de type fermé et rotor à cage, ventilation extérieure et puissance à l'arbre comprise entre 1,1 et 90 KW, alimentation à 400V- 50 Hz en service continu S1.*

*C'est au choix de chaque constructeur de moteurs électriques de décider de classer ces produits dans une des trois classes de rendement ci-dessus. Dans ce cas, le constructeur doit faire apparaître le logo de la classe de rendement sur la plaque marque et introduire, dans les caractéristiques techniques, les valeurs de rendement à pleine charge et à ¾ de la charge nominale.*

*Le moteurs Bonfiglioli concernées dans cet accord, sont conformes à la classe de rendement **eff2** et de conséquence ils présentent, sur la plaque marque, le logo suivant :*



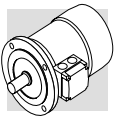

### Tolleranze

Secondo le Norme sono ammesse le tolleranze indicate nella tabella seguente sulle grandezze garantite.

### Tolerances

As per the Norms applicable the tolerances here below apply to the following quantities.

### Toleranzen

Die Normen lassen die in folgenden Tabelle genannten Toleranzen bei den garantierten Größen zu.

### Tolérances

Selon les Normes, les tolérances indiquées dans le tableau ci-dessous sont admises sur les tailles garanties.

(A29)

-0.15 (1 - $\eta$ ) P $\leq$ 50kW	Rendimento	Efficiency	Wirkungsgrad	Rendement
$-(1 - \cos\phi)/6$ min 0.02 max 0.07	Fattore di potenza	Power factor	Leistungsfaktor	Facteur de puissance
$\pm 20\%$ *	Scorrimento	Slip	Schlupf	Glissement
+20%	Corrente a rotore bloccato	Locked rotor current	Strom bei blockiertem Läufer	Courant à rotor bloqué
-15% +25%	Coppia a rotore bloccato	Locked rotor torque	Drehmoment bei blockiertem Läufer	Couple à rotor bloqué
-10%	Coppia max	Max. torque	Max. Drehmoment	Couple max

\*  $\pm 30\%$  per motori con Pn < 1 kW

\*  $\pm 30\%$  for motors with Pn < 1 kW

\*  $\pm 30\%$  für Motoren mit Pn < 1 kW

\*  $\pm 30\%$  pour moteurs avec Pn < 1 kW

### M3 - CARATTERISTICHE MECCANICHE

#### Forme costruttive

I motori serie BN sono previsti nelle forme costruttive indicate in tabella (A30) secondo le Norme CEI EN 60034-14.

Le forme costruttive sono le seguenti:

**IM B5** (base)  
IM V1, IM V3 (derivate)

**IM B14** (base)  
IM V18, IM V19 (derivate)

I motori in forma costruttiva IM B5 possono essere installati nelle posizioni IM V1 e IM V3; i motori in forma costruttiva IM B14 possono essere installati nelle posizioni IM V18 e IM V19. In questi casi, sulla targa del motore sarà indicata la forma costruttiva base IM B5 o IM B14. Nelle forme costruttive dove il motore assume una posizione verticale con albero in basso, si consiglia di richiedere l'esecuzione con tettuccio parapioggia (da prevedere sempre nel caso di motori autofrenanti). Tale esecuzione, presente nelle opzioni, va richiesta espressamente in fase di ordine in quanto non è prevista nella versione base.

### M3 - MECHANICAL FEATURES

#### Versions

IEC-normalised BN motors are available in the design versions indicated in table (A30) as per Standards CEI EN 60034-14.

Mounting versions are:

**IM B5** (basic)  
IM V1, IM V3 (derived)

**IM B14** (basic)  
IM V18, IM V19 (derived)

IM B5 design motors can be installed in positions IM V1 and IM V3; IM B14 design motors can be installed in positions IM V18 and IM V19. In such cases, the basic design IM B5 or IM B14 is indicated on the motor name plate. In design versions with a vertically located motor and shaft downwards, it is recommended to request the drip cover (always necessary for brake motors). This facility, included in the option list should be specified when ordering as it does not come as a standard device.

### M3 - MECHANISCHE EIGENSCHAFTEN

#### Bauformen

Die Motoren der Serie BN weisen die in der Abbildung (A30) angegebene Bauform gemäß den Normen CEI EN 60034-14 auf.

Die Bauformen sind:

**IM B5** (Grundmodell)  
IM V1, IM V3 (Ableitungen)

**IM B14** (Grundmodell)  
IM V18, IM V19 (Ableitungen)

Die Motoren mit der Bauform IM B5 können mit den Einbaulagen IM V1 und IM V3 eingebaut werden; die Motoren mit der Bauform IM B14 können mit den Einbaulagen IM V18 und IM V19 eingebaut werden. In diesen Fällen ist auf dem Leistungsschild des Motors die Bauform IM B5 oder IM B14 angegeben. Bei Bauformen mit vertikaler Lage des Motors und nach unten gerichteter Welle wird die Ausführung mit Regenschutzabdeckung empfohlen (bei Bremsmotoren stets vorzusehen). Dieses wahlweise Zubehör muß ausdrücklich zum Zeitpunkt der Bestellung verlangt werden, da es bei der Grundausführung nicht vorgesehen ist.

### M3 - CARACTERISTIQUES MECANQUES

#### Formes de construction

Les moteurs série BN sont prévus dans les formes de construction indiquées sur le tableau (A30) selon les normes CEI EN 60034-14.

Les formes de construction sont les suivantes:

**IM B5** (base)  
IM V1, IM V3 (dérivées)

**IM B14** (base)  
IM V18, IM V19 (dérivées)

Les moteurs en forme de construction IM B5 peuvent être installés dans les positions IM V1 et IM V3; les moteurs en forme de construction IM B14 peuvent être installés dans les positions IM V18 et IM V19. Dans ces cas, la forme de construction base IM B5 ou IM B14 sera indiquée sur la plaque du moteur. Dans les formes de construction où le moteur présente une position verticale avec arbre vers le bas, nous conseillons de demander l'exécution avec capot de protection contre la pluie (à prévoir toujours dans le cas de moteurs freins). Cette exécution, prévue dans les options, doit être expressément demandée en phase de commande étant donné qu'elle n'est pas prévue dans la version de base.

(A30)

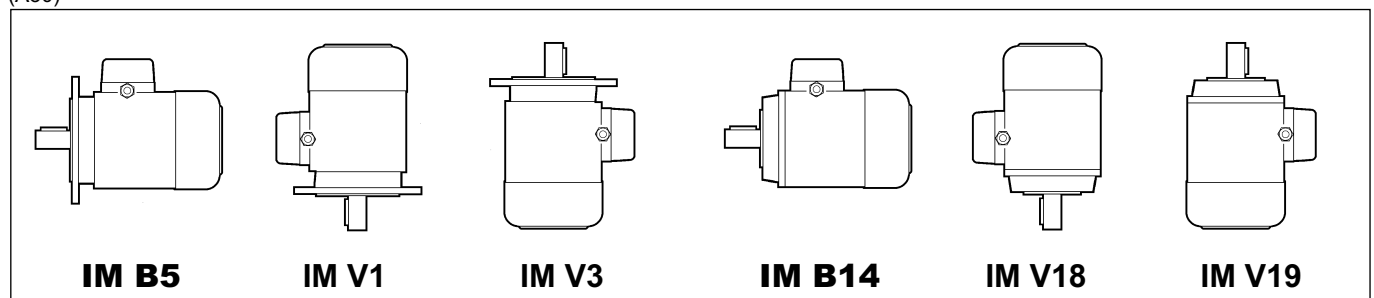

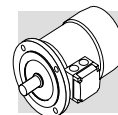

I motori in forma flangiata possono essere forniti con dimensioni di accoppiamento ridotte, come riportato in tabella (A31) - esecuzioni **B5R**, **B14R**.

*Flanged motors can be supplied with a reduced mounting interface, as shown in chart (A31) below.*

Die Motoren in der Auslegung mit Flansch können mit reduzierten Passmassen gemäß Tabelle (A31) - Versionen **B5R**, **B14R** geliefert werden.

*Les moteurs avec forme à bride peuvent être fournis avec des tailles d'accouplement réduites, comme indiqué dans le tableau (A31) - exécutions **B5R**, **B14R**.*

(A31)

	<b>BN 71</b>	<b>BN 80</b>	<b>BN 90</b>	<b>BN 100</b>	<b>BN 112</b>	<b>BN 132</b>
	DxE - Ø					
<b>B5R</b> <sup>(1)</sup>	11x23 - 140	14x30 - 160	19x40 - 200	24x50 - 200	24x50 - 200	28x60 - 250
<b>B14R</b> <sup>(2)</sup>	11x23 - 90	14x30 - 105	19x40 - 120	24x50 - 140	—	—

<sup>(1)</sup> flangia con fori passanti

<sup>(1)</sup> flange with through holes

<sup>(1)</sup> Flansch mit durchgehenden Bohrungen

<sup>(1)</sup> bride avec orifices passants

<sup>(2)</sup> flangia con fori filettati

<sup>(2)</sup> flange with threaded holes

<sup>(2)</sup> Flansch mit Gewindebohrungen

<sup>(2)</sup> bride avec orifices filetés

## IP..

### Grado di protezione

### Degree of protection

### Schutzart

### Degré de protection

La tabella sottostante riassume la disponibilità dei vari gradi di protezione.

Indipendentemente dal grado di protezione specificato, per installazione all'aperto i motori devono essere protetti dall'irraggiamento diretto e, nel caso d'installazione con albero rivolto verso il basso, è necessario specificare ulteriormente il tettuccio di protezione contro l'ingresso di acqua e corpi solidi (opzione **RC**).

*The following chart provides an overview of the degrees of protection available.*

*In addition to the degree of protection specified when ordering, motors to be installed outdoors require protection against direct sunlight and also – when they are to be installed vertically down – a drip cover to prevent the ingress of water and solid particles (option **RC**).*

In der nachstehenden Tabelle werden die jeweils zur Verfügung stehenden Schutzarten zusammengefasst.

Unabhängig von der spezifischen Schutzart müssen die im Freien installierten Motoren vor direkten Strahlungen geschützt werden. Im Fall einer senkrechten Montage, in der die Welle nach unten gerichtet ist, sollte darüber hinaus das Schutzdach bestellt werden, das vor dem Eindringen von Wasser und festen Fremdkörpern schützt (Option **RC**).

*Le tableau ci-dessous résume la disponibilité des différents degrés de protection.*

*Indépendamment du degré de protection spécifié, en cas d'installation en plein air, les moteurs doivent être protégés des rayons directs du soleil et, en cas d'installation avec l'arbre dirigé vers le bas, il est nécessaire de spécifier ultérieurement le capot de protection contre la pénétration de l'eau et des corps solides (option **RC**).*

(A32)

		<b>IP 54</b>	<b>IP 55</b>	<b>IP 56</b>
<b>BN</b>	<b>M</b>	⊘	standard	
<b>BN_FD</b> <b>BN_FA</b>	<b>M_FD</b> <b>M_FA</b>	standard		⊘
<b>BN_BA</b>	—	⊘	standard	⊘

### Ventilazione

### Cooling

### Lüftung

### Ventilation

I motori sono raffreddati mediante ventilazione esterna (IC 411 secondo CEI EN 60034-6) e sono provvisti di ventola radiale

*The motors are externally ventilated (IC 411 to CEI EN 60034-6) and are equipped with a plastic fan working in both directions.*

Die Motoren sind eigenbelüftet (IC 411 gemäß CEI EN 60034-6) und verfügen über ein Radiallüfterrad aus Kunststoff, das in beiden

*Les moteurs sont refroidis à l'aide d'une ventilation extérieure (IC 411 selon CEI EN 60034-6) et sont dotés d'un ven-*

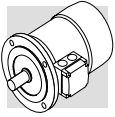

in plastica che funziona in entrambi i sensi di rotazione. L'installazione deve assicurare una distanza minima dalla calotta copriventola alla parete in modo da non avere impedimenti all'ingresso aria e permettere la possibilità di eseguire l'opportuna manutenzione del motore e, se previsto, del freno. Su richiesta è possibile prevedere una ventilazione forzata indipendente (opzione U1). Questa soluzione consente di aumentare il fattore di utilizzo del motore nel caso di alimentazione da inverter e funzionamento a giri ridotti.

*The motors must be installed allowing sufficient space between fan cowl and the nearest wall to ensure free air intake and allow access for maintenance purposes on motor and brake, if supplied.*  
*Independent, forced air ventilation (IC 416) can be supplied on request (option U1).*  
*This solution enables to increase the motor duty factor when driven by an inverter and operating at reduced speed.*

Drehrichtungen arbeiten kann. Bei der Installation muß sichergestellt werden, daß die Lüfterradabdeckung soweit von der Wand entfernt ist, daß der Motor und (falls vorhanden) die Bremse problemlos gewartet werden können. Auf Wunsch können die Motoren mit Fremdbelüftung geliefert werden (Option U1). Diese Lösung ermöglicht das Motorbetriebsfaktor zu erhöhen, wenn vom Frequenzumrichter gesteuert und zu niedrigen Geschwindigkeit betrieben.

*tilateur à ailettes en plastique qui fonctionne dans les deux sens de rotation.*  
*L'installation doit assurer une distance minimum entre le capot de protection du ventilateur et la paroi afin de permettre une bonne circulation de l'air et rendre plus aisé l'entretien du moteur et si prévu, du frein.*  
*Sur demande, il est possible de prévoir une ventilation forcée indépendante (option U1).*  
*Cette solution permet d'augmenter le facteur d'utilisation du moteur en cas d'alimentation, via un variateur de fréquence, et pour un fonctionnement à faible vitesse.*

**Senso di rotazione**

È possibile il funzionamento in entrambi i sensi di rotazione. Con collegamento dei morsetti U1,V1,W1 alle fasi di linea L1,L2,L3 si ha rotazione oraria vista dal lato accoppiamento, mentre la marcia antioraria si ottiene scambiando fra loro due fasi.

**Direction of rotation**

*Rotation is possible in both directions. If terminals U1, V1, and W1 are connected to line phases L1,L2 and L3, clockwise rotation (looking from drive end) is obtained. For counterclockwise rotation, switch two phases.*

**Drehrichtung**

Der Betrieb in beiden Drehrichtungen ist möglich. Schließt man die Klemmen U1, V1, W1 an die Phasen L1, L2, L3 an, dreht sich der Motor im Uhrzeigersinn (von der Verbindungsseite her betrachtet); die Drehung im Gegenuhrzeigersinn erhält man, indem man zwei Phasen vertauscht.

**Sens de rotation**

*Un fonctionnement dans les deux sens de rotation est possible. Avec raccordement des bornes U1, V1,W1 aux phases de ligne L1, L2,L3, on a la rotation dans le sens des aiguilles d'une montre vue du côté liaison alors que le sens inverse s'obtient en intervertissant les deux phases entre elles.*

**Rumorosità**

I valori di rumorosità, rilevati secondo il metodo previsto dalle Norme ISO 1680, sono contenuti entro i livelli massimi previsti dalle Norme CEI EN 60034-9.

**Noise**

*Noise levels, measured using the method prescribed by ISO 1680 Standards, are within the maximum levels specified by Standards CEI EN 60034-9.*

**Geräuschpegel**

Die mit der von der ISO-Norm 1680 vorgesehenen Methoden gemessenen Lärmstärkewerte liegen innerhalb der gemäß den Normen CEI EN 60034-9 zulässigen Höchstgrenzen.

**Niveau de bruit**

*Les valeurs relevées selon la méthode prévue par les normes ISO 1680 sont situées sous les niveaux maximums prévus par les normes CEI EN 60034-9.*

**Vibrazioni ed equilibratura**

Tutti i rotori sono equilibrati con mezza linguetta e rientrano nei limiti di intensità di vibrazione previsti dalle Norme CEI EN 60034-14. Per particolari esigenze di silenziosità potrà essere previsto, a richiesta, un'esecuzione antivibrante in grado ridotto R. La tabella seguente riporta i valori della velocità efficace di vibrazione per equilibratura standard (N) e incrementata (R).

**Vibrations and balancing**

*Rotor shafts are balanced with half key fitted and fall within the vibration class N, as per Standard CEI EN 60034-14. If a further reduced noise level is required improved balancing can be optionally requested (class R). Table below shows the value for the vibration velocity for standard (N) and improved (R) balancing.*

**Schwingungen und Ausgleich**

Alle Rotoren werden durch einen halben Federkeil ausgeglichen und fallen somit unter die, von den Normen CEI EN 60034-14 vorgesehenen Schwingungsradargrenzen. Bei besonderen Anforderungen an die Laufruhe kann auf Anfrage eine schwingungsdämpfende Ausführung in der reduzierten Klasse (R) geliefert werden. Die folgende Tabelle führt die Werte der Ist-Schwingungsgeschwindigkeit für einen normalen (N) und verbesserten (R) Ausgleich auf.

**Vibrations et équilibrage**

*Tous les rotors sont équilibrés avec une demi languette et rentret dans les limites d'intensité de vibration prévues par les Normes CEI EN 60034-14. En cas d'exigences particulière concernant le niveau de bruit, sur demande, il est possible de réaliser une exécution anti-vibrante, de degré réduit (R). Le tableau ci-dessous indique les valeurs de la vitesse efficace de vibration pour un équilibrage standard (N) et améliorée (R).*

(A33)

Grado di vibrazione Vibration class Schwingungsklasse Degré de vibration	Velocità di rotazione Angular velocity Drehungsgeschwindigkeit Vitesse de rotation	Limiti della velocità di vibrazione Limits of the vibration velocity Grenzen der Schwingungsgeschwindigkeit Limites de la vitesse de vibration	
		[mm/s]	
	n [min <sup>-1</sup> ]	BN 56...BN 132 M05...M4	BN 160MR...BN 200 M5
<b>N</b>	600 ≤ n ≤ 3600	1.8	2.8
<b>R</b>	600 ≤ n ≤ 1800	0.71	1.12
	1800 < n ≤ 3600	1.12	1.8

I valori si riferiscono a misure con motore liberamente sospeso e funzionamento a vuoto.

*Values refer to measures with freely suspended motor in unloaded conditions.*

Die Werte beziehen sich auf die Abmessungen mit stehendem Motor, ohne Getriebe und Leerlauf.

*Les valeurs se réfèrent à des mesures avec moteur librement suspendu et fonctionnement à vide.*

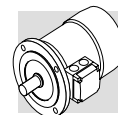

### Morsettiera motore

La morsettiera principale è a sei morsetti per collegamento con capicorda. All'interno della scatola è previsto un morsetto per il conduttore di terra.

Le dimensioni dei perni di attacco sono riportate nella tabella seguente.

Nel caso di motori autofrenanti, il raddrizzatore per l'alimentazione del freno è fissato all'interno della scatola e provvisto di adeguati morsetti di collegamento.

Eseguire i collegamenti secondo gli schemi riportati all'interno della scatola coprimorsetti o nei manuali d'uso.

### Terminal box

Terminal board features 6 studs for eyelet terminal connection. A ground terminal is also supplied for earthing of the equipment.

Terminals number and type are shown in the following table.

Brakemotors house the a.c./d.c. rectifier (factory pre-wired) inside the terminal box.

Wiring instructions are provided either in the box or in the user manual.

### Motorklemmenkasten

Die Hauptklemmleiste hat 6 Klemmen für den Anschluß mit Kabelschuhen. Im Innern des Klemmenkastens befindet sich eine Klemme für den Erdleiter.

Die Abmessungen der Ausschüsse sind in der folgenden Tabelle angegeben.

Bei den Bremsmotoren befindet sich auch der mit den erforderlichen Anschlußklemmen ausgestattete Gleichrichter für die Stromversorgung der Bremse im Klemmenkasten.

Die Anschlüsse müssen gemäß den Diagrammen im Klemmkasten oder in den Betriebsanweisungen durchgeführt werden.

### Bornier moteur



Le bornier principal prévoit six bornes pour raccordement avec cosses. Dans le boîtier se trouve une borne pour le conducteur de terre.

Les dimensions des axes de fixation sont reportées dans le tableau ci-dessous.

Dans le cas de moteurs freins, le redresseur pour l'alimentation du frein est fixé à l'intérieur du boîtier et est doté de bornes de raccordement.

Effectuer les connexions selon les schémas indiqués à l'intérieur du bornier, ou dans les manuels d'utilisation.

(A34)

		N° terminali No. of terminals Klemmen N° bornes	Filettatura terminali Terminal threads Gewinde Filetage bornes	Sezione max del conduttore Wire max cross section area Max. leiterquerschnitt Section max du conducteur mm <sup>2</sup>
BN 56...BN 71	M05, M1	6	M4	2.5
BN 80, BN 90	M2	6	M4	2.5
BN 100...BN 112	M3	6	M5	6
BN 132...BN 160MR	M4	6	M5	6
BN 160M...BN 180M	M5	6	M6	16
BN 180L...BN 200L	-	6	M8	25

### Ingresso cavi

Nel rispetto della Norma EN 50262, i fori di ingresso cavi nelle scatole morsettiera presentano filettature metriche della misura indicata nella tabella seguente.

### Cable entry

The holes used to bring cables to terminal boxes use metric threads in accordance with standard EN 50262 as indicated in the table here after.



### Kabeleingang

Unter Berücksichtigung der Norm EN 50262 verfügen die Kabeleingänge in die Klemmenkästen über metrische Gewinde, deren Maße, der nachstehenden Tabelle entnommen werden können.

### Entrée câbles

Dans le respect de la Norme EN 50262, les orifices d'entrée câbles dans les boîtes à bornes présentent des filetages métriques de la taille indiquée dans le tableau ci-dessous.

(A35)

		Ingresso cavi / Cable entry kabeldurchführung / Entrée câbles	Diametro max. cavo allacciabile / Max. cable diameter allowed Max. zulässiger Kabeldurchmesser / Diam. maxi câble [mm]
BN 63	M05	2 x M20 x 1.5	13
BN 71	M1	2 x M25 x 1.5	17
BN 80 - BN 90	M2	2 x M25 x 1.5	17
BN 100	M3	2 x M32 x 1.5	21
		2 x M25 x 1.5	17
BN 112	—	2 x M32 x 1.5 4 x M25 x 1.5	17
BN 132...BN 160MR	M4	4 x M32 x 1.5	21
BN 160M...BN 200L	M5	2 x M40 x 1.5	29



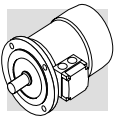

### Cuscinetti

I cuscinetti previsti sono del tipo radiale a sfere con lubrificazione permanente precaricati assialmente.

I tipi utilizzati sono indicati nelle tabelle seguenti. La durata nominale a fatica  $L_{10h}$  dei cuscinetti, in assenza di carichi esterni applicati è superiore a 40.000 ore, calcolata secondo ISO 281.

**DE** = lato comando

**NDE** = lato opposto comando

### Bearings

*Life lubricated preloaded radial ball bearings are used, types are shown in the chart here under. Calculated endurance lifetime  $L_{10}$ , as per ISO 281, in unloaded condition, exceeds 40000 hrs.*

**DE** = drive end

**NDE** = non drive end

### Lager

Bei den Lagern handelt es sich um Radialkugellager mit Dauerschmierung.

Die verwendeten Typen sind in den folgenden Tabellen angegeben.

Die Lebensdauer der Lager bei einer Beanspruchung  $L_{10h}$  ist, sofern keine externen Kräfte wirken, über 40.000 Stunden (Berechnung gemäß ISO 281).

**DE** = Wellenseite

**NDE** = Lüfterseite

### Roulements

*Les roulements prévus sont du type radial à billes avec lubrification permanente.*

*Les types utilisés sont indiqués dans les tableaux ci-dessous.*

*La résistance à la déformation  $L_{10h}$  des roulements en absence de charges extérieures appliquées est supérieure à 40.000 heures calculée selon ISO 281.*

**DE** = sortie arbre

**NDE** = côté ventilateur

(A36)

	<b>DE</b>	<b>NDE</b>	
	<b>M, M_FD, M_FA</b>	<b>M</b>	<b>M_FD; M_FA</b>
<b>M05</b>	6004 2Z C3	6201 2Z C3	6201 2RS C3
<b>M1</b>	6004 2Z C3	6202 2Z C3	6202 2RS C3
<b>M2</b>	6007 2Z C3	6204 2Z C3	6204 2RS C3
<b>M3</b>	6207 2Z C3	6206 2Z C3	6206 2RS C3
<b>M4</b>	6309 2Z C3	6308 2Z C3	6308 2RS C3
<b>M5</b>	6309 2Z C3	6309 2Z C3	6309 2RS C3

(A37)

	<b>DE</b>	<b>NDE</b>	
	<b>BN, BN_FD, BN_FA, BN_BA</b>	<b>BN, BN_BA</b>	<b>BN_FD; BN_FA</b>
<b>BN 56</b>	6201 2Z C3	6201 2Z C3	–
<b>BN 63</b>	6201 2Z C3	6201 2Z C3	6201 2RS C3
<b>BN 71</b>	6202 2Z C3	6202 2Z C3	6202 2RS C3
<b>BN 80</b>	6204 2Z C3	6204 2Z C3	6204 2RS C3
<b>BN 90</b>	6205 2Z C3	6205 2Z C3	6305 2RS C3
<b>BN 100</b>	6206 2Z C3	6206 2Z C3	6206 2RS C3
<b>BN 112</b>	6306 2Z C3	6306 2Z C3	6306 2RS C3
<b>BN 132</b>	6308 2Z C3	6308 2Z C3	6308 2RS C3
<b>BN 160MR</b>	6309 2Z C3	6308 2Z C3	6308 2RS C3
<b>BN 160M/L</b>	6309 2Z C3	6309 2Z C3	6309 2RS C3
<b>BN 180M</b>	6310 2Z C3	6309 2Z C3	6309 2RS C3
<b>BN 180L</b>	6310 2Z C3	6310 2Z C3	6310 2RS C3
<b>BN 200L</b>	6312 2Z C3	6310 2Z C3	6310 2RS C3

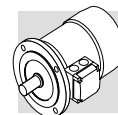

#### M4 - CARATTERISTICHE ELETTRICHE

#### M4 - ELECTRICAL CHARACTERISTICS

#### M4 - ELEKTRISCHE EIGENSCHAFTEN

#### M4 - CARACTERISTIQUES ELECTRIQUES

##### Tensione

I motori a una velocità sono previsti nell'esecuzione normale per tensione nominale 230V Δ / 400V Y, 50 Hz con tolleranza di tensione ± 10% (escluso i tipi M3LC4 e M3LC6).

In targa sono indicati oltre alla tensione nominale i campi di funzionamento consentiti, p.e.:

220 - 240V Δ

380 - 415V Y / 50 Hz.

In accordo alle Norme CEI EN 60034-1 i motori possono funzionare alle tensioni sopra indicate con tolleranza del ± 5%.

Per funzionamento ai limiti di tolleranza la temperatura può superare di 10 K il limite previsto dalla classe di isolamento adottata.

Ad eccezione dei motori autofrenanti tipo BN\_FD in targa vengono indicati anche i valori corrispondenti al funzionamento a 60 Hz (p.e. 460Y, 60 Hz) ed il relativo campo di tensione:

440 - 480VY, 60 Hz.

Per i motori autofrenanti con freno tipo FD le tensioni standard sono:

220V - 240V Δ - 50 Hz

380V - 415V Y - 50 Hz

con tensione di alimentazione freno 230V ± 10%.

La tabella seguente riporta le tensioni previste per i motori.

##### Voltage

Single speed motors are rated for 230/400 V - 50 Hz.

A tolerance of ±10% applies to nominal voltage, with the exception of motors type M3LC4 and M3LC6.

In addition to nominal voltage-frequency values the name plate also shows voltage ranges the motor can operate under, e.g.:

220-240V Δ - 50 Hz

380-415V Y - 50 Hz

As per Norms CEI EN 60034-1 on above voltage values the ±5% tolerance applies.

When operating close to the tolerance limit values the winding temperature can exceed by 10 K the rated temperature for the given insulation class.

With the exception of BN\_FD brakemotors, the rated voltage values for operation under 60 Hz mains are also shown on the nameplate, e.g. 460Y-60 Hz along with related tolerance field, e.g. 440-480V Y-60 Hz.

For brakemotors, FD type, rated voltage is:

220-240V Δ - 50 Hz

380-415V Y - 50 Hz

Brake supply is a.c. 230V ±10% single phase.

Chart below shows standard and optional wiring of motors.

##### Spannung

Die eintourigen Motoren müssen in der Standardausführung mit einer Spannung von 230 V Δ / 400 V Y, 50 Hz mit einer Toleranz von ± 10% gespeist werden (Type M3LC4 und M3LC6 ausgenommen).

Auf dem Schild werden die Nennspannung hinaus, auch die zulässigen Ansprechbereiche angegeben, z.B.:

220-240V Δ

380-415V Y/50 Hz.

Gemäß den Normen CEI EN 60034-1 können die Motoren auf die oben genannten Spannungen mit Toleranzen von ± 5% arbeiten. Bei Betrieb an den Spannungsgrenzen, kann die Temperatur bis zum 10K die für die verwendeten Isolierstoffklasse angegebenen Grenze überschreiten.

Darüber hinaus wird auf den Typenschild die dem 60 Hz-Betrieb entsprechenden Werte angegeben (d.h. 460 Y, 60 Hz) und das entsprechende Spannungsfeld, 440-480VY, 60 Hz.

Für die selbstbremsenden Motoren mit dem Bremstyp FD sind die Standardspannungen folgende:

220V - 240V Δ - 50 Hz

380V - 415V Y - 50 Hz

mit Bremsspannungsversorgung von 230V ± 10%.

Die folgende Tabelle für die Motoren vorgesehenen Spannungen auf.

##### Tension

Les moteurs à polarité unique sont prévus dans l'exécution normale pour tension 230V Δ / 400V Y, 50 Hz avec tolérance de tension ± 10% (sauf les types M3LC4 et M3LC6).

Outre la tension nominale, les plages de fonctionnement permises sont indiquées sur la plaquette signalétique, à savoir:

220-240V Δ

380-415V Y/50 Hz.

Selon les normes CEI EN 60034-1 les moteurs peuvent fonctionner aux tension indiquées ci-dessus avec une tolérance de ± 5%.

Pour un fonctionnement à la limite de tolérance, la température peut dépasser les 10K, la limite prévue de la classe d'isolation choisie.

Sur la plaque marque sont de plus indiqués les valeurs correspondantes au fonctionnement en 60 Hz (ex.460Y, 60 Hz) et la relative plage de tension: 440 - 480VY, 60 Hz.

En ce qui concerne les moteurs autofrenants avec frein de type FD, les tensions standard sont les suivantes :

220V - 240V Δ - 50 Hz

380V - 415V Y - 50 Hz

avec tension d'alimentation du frein 230V ± 10%.

La tableau ci-dessous indique les tensions prévues pour les moteurs.

(A38)

		BN M	BN_FD M_FD			BN_FA / BN_BA M_FA		Esecuzione Configuration Version Execution
			$V_{mot} \pm 10\%$ 3~	$V_{mot} \pm 10\%$ 3~	$V_B \pm 10\%$ 1~	$V_{mot} \pm 10\%$ 3~	$V_B \pm 10\%$ 3~	
BN 56 - BN 132	M05...M4	230/400 - 50Hz 460 - 60Hz	230/400V Δ/Y - 50 Hz	230V	230/400V Δ/Y - 50 Hz 460V Y - 60Hz	230/400V Δ/Y - 50 Hz 460V Y - 60Hz	Standard	
BN 100 - BN 132	M3 - M4	400/690 - 50Hz 460 - 60Hz	400/690V Δ/Y - 50 Hz	400V	400/690V Δ/Y - 50 Hz 460V Y - 60Hz	400/690V Δ/Y - 50 Hz 460V Y - 60Hz	A richiesta, senza sovrapprezzo On request at no extra charge Auf Anfrage, ohne Aufpreis Sur demande, sans majoration de prix	

I motori a due velocità 400V/50Hz, sono previsti per tensione nominale standard 400V; tolleranze applicabili secondo CEI EN 60034-1.

Nella tabella seguente sono indicati i vari tipi di collegamenti previsti per i motori in funzione della polarità.

The only rated voltage for motors type 400V/50Hz and all double speed motors is 400V. Applicable tolerances as per CEI EN 60034-1.

The table below shows the wiring options available.

Alle polumschaltbaren Motoren, die Typen 400V/50Hz, sind nicht umschaltbar, standard-mäßig nur für ein Spannung 400V vorgesehen; geltenden Toleranzen gemäß CEI EN 60034-1.

Auf die folgende Tabelle werden die verschiedenen für die Motoren vorgesehenen Anschlußtypen angegeben.

Tous les moteur à deux vitesses, les types 400V/50Hz, sont prévus pour une tension nominale standard de 400V; tolérances applicables selon CEI EN 60034-1.

Dans le tableau ci-dessous sont indiqués les différents types de connexion prévus pour les moteurs.

(A39)

		Poli / Pole / Polig / Pôles	Collegamento avvolgimento / Wiring options Wicklungsanschluß / Connexion du bobinage
		BN 56...BN 200	M05...M5

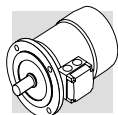

## Frequenza

I motori ad una velocità nell'esecuzione standard riportano in targa oltre alle tensioni del funzionamento a 50 Hz il campo di tensione 440 - 480V 60 Hz (escluso motori autofrenanti con freno FD) con potenza aumentata di circa il 20%

La potenza di targa dei motori a 60Hz corrisponde a quanto riportato nella tabella (A40) seguente:

## Frequency

*With the exception of brakemotors, name plate of standard single speed motors shows, besides the 50 Hz voltage ratings, also the rated power output for 60 Hz operation in the 440-480 V range.*

*Power output is increased by approx 20%.*

*Rated output power for 60 Hz operation is shown in the following diagram.*

## Frequenz



Bei eintourigen Motoren in der Standardausführung wird außer den 50 Hz-Betriebsspannungen auch den Spannungsfeld 440 - 480V 60 Hz angegeben (mit Ausnahme von Bremsmotoren mit Bremsentyp FD) mit einer erhöhten Leistung von ungefähr 20%. Die Leistung auf das Namensschild von 60 Hz-Motoren entspricht den Daten aus der folgenden Tabelle (A40):

## Fréquence

*Les moteurs à une vitesse en exécution standard reportent sur la plaque marquée en plus des tensions du fonctionnement à 50 Hz la plage de tension 440 - 480V 60 Hz (moteurs freins avec frein FD exclus) avec puissance augmentée de 20% env.*

*La puissance sur la plaque marquée des moteurs à 60 Hz correspond à celle indiquée au tableau (A40) suivant:*

(A40)

		2P	4P	6P
		P <sub>n</sub> [kW]		
BN 56A	-	-	0.06	-
BN 56B	M0B	-	0.10	-
BN 63A	M05A	0.21	0.14	0.10
BN 63B	M05B	0.30	0.21	0.14
BN 71A	M05C	0.45	0.30	0.21
BN 71B	M1SD	0.65	0.45	0.30
BN 80A	M1LA	0.90	0.65	0.45
BN 80B	M2SA	1.30	0.90	0.65
BN 90S	M2SB	-	1.30	0.90
BN 90SA	M2SB	1.8	-	-
BN 90L	M3SA	2.5	-	1.3
BN 90LA	M3SA	-	1.8	-
BN 100L	M3LA	3.5	-	-
BN 100LA	M3LA	-	2.5	1.8
BN 100LB	M3LB	4.7	3.5	2.2
BN 112M	M3LB	4.7	4.7	2.5
	M3LC	-	4.7	2.5
BN 132S	M4SA	-	6.5	3.5
BN 132SA	M4SA	6.3	-	-
BN 132SB	M4SB	8.7	-	-
BN 132M	M4LA	11	-	-
BN 132MA	M4LA	-	8.7	4.6
BN 132MB	M4LB	-	11	6.5
BN 160MR	M4LC	12.5	12.5	-
BN 160MB	M5SB	17.5	-	-
BN 160M	M5SA	-	-	8.6
BN 160L	M5S	21.5	17.5	12.6
BN 180M	M5LA	24.5	21.5	-
BN 180L	-	-	25.3	17.5
BN 200L	-	34	34	22

Motori a doppia polarità alimentati a 60 Hz avranno un aumento della potenza nominale, riferita a 50 Hz, pari al 15%.

Qualora sulla targhetta di un motore destinato ad essere alimentato a 60 Hz sia richiesto un valore di potenza nominale pari a quello normalizzato a 50 Hz specificare in designazione l'opzione PN.

*For two-speed motors operated under 60 Hz supply the rated power output is increased by 15% as compared to same motor with 50 Hz supply.*

*If same IEC-normalised 50 Hz power rating value is desired on name plate of a 60 Hz operated motor specify option PN in the ordering code.*

*Standard motors wound for 50*

Für polumschaltbare Motoren mit 60 Hz Spannungsversorgung ist die vorgesehene Leistungserhöhung gemäß den Datenblätter von 15%.

Wenn die angefragte 60 Hz-Leistung der normierten 50 Hz-Leistung entspricht, geben bei der Bezeichnung das Option PN an. Die Motoren mit einer Wicklung für eine Frequenz von 50 Hz

*Pour les moteurs à deux vitesses avec alimentation 60 Hz l'augmentation de puissance prévue par rapport aux valeurs indiquées dans les tableaux techniques, sera de 15%.*

*Si la puissance requise à 60 Hz correspond à la puissance normalisée à 50 Hz on devra indiquer l'option PN.*

*Les moteurs bobinés pour fré-*

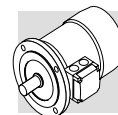

I motori normalmente avvolti per frequenza 50 Hz possono essere usati in reti a 60 Hz con i loro dati che saranno corretti come da tabella seguente.  
I freni, se presenti, dovranno sempre essere alimentati alla tensione  $V_b$ , riportata in targa.

*Hz supply can be operated under 60 Hz with main data corrected as per chart below:  
Brakes, if fitted, must be supplied with the voltage value  $V_b$  that is stated on the nameplate.*

können entsprechend den Angaben von Tabelle (A40) an Netze mit 60 Hz angeschlossen werden.  
Die Bremse muss, falls angebaut, mit der auf dem Typenschild angegebenen Spannung  $V_b$  betrieben werden.

*quence 50 Hz peuvent être utilisés sur réseau à 60 Hz selon les indications du tableau (A40).  
Les freins, si présents, devront toujours être alimentés avec la tension  $V_b$  rapportée sur la plaque.*

(A41)

50 Hz	60 Hz			
V - 50 Hz	V - 60 Hz	P <sub>n</sub> - 60 Hz	M <sub>n</sub> , M <sub>a</sub> /M <sub>n</sub> - 60 Hz	n [min <sup>-1</sup> ] - 60 Hz
230/400 Δ/Y	220 - 240 Δ 380 - 415 Y	1	0.83	1.2
400/690 Δ/Y	380 - 415 Δ			
230/400 Δ/Y	265 - 280 Δ 440 - 480 Y	1.15	1	1.2
400/690 Δ/Y	440 - 480 Δ			

#### Potenza nominale

Le tabelle dei dati tecnici del catalogo riportano le caratteristiche funzionali a 50 Hz in condizioni ambientali standard secondo le Norme CEI EN 60034-1 (temperatura 40 °C e altitudine <1000 m s.l.m.).  
I motori possono essere impiegati a temperature comprese tra 40 °C e 60 °C applicando i declassamenti di potenza indicati nelle tabelle seguenti.

#### Rated power

*Catalogue rating values are calculated for 50 Hz operation and for standard ambient conditions (temperature 40 °C; elevation <1000 m a.s.l.) as per the CEI EN 60034-1 Standards.  
The motors can be used within the 40 - 60 °C temperature range with rated power output adjusted by factors given in the following charts.*

#### Nennleistung

Die Betriebsdatentabellen des Katalogs enthalten die technischen Daten bei einer Frequenz von 50 Hz bei normalen Umgebungsbedingungen gemäß den Normen CEI EN 60034-1 (Temperatur 40°C und Höhe <1000 m ü.d.M.). Die Motoren können in größeren Temperaturen zwischen 40°C und 60°C betrieben werden, wenn man die in den Tabellen (A41) angegebenen Rückstufungen anwendet.

#### Puissance nominale

*Les tableaux fonctionnels du catalogue présentent les caractéristiques techniques à 50 Hz dans des conditions ambiantes standard selon les normes CEI EN 60034-1 (température 40°C et altitude <1000 m).  
Les moteurs peuvent être employés à des températures comprises entre 40°C et 60°C en appliquant les déclassements de puissance indiqués dans les tableaux suivantes.*

(A42)

Temperatura ambiente / Ambient temperature / Umgebungstemperatur / Température ambiante(°C)	40°	45°	50°	55°	60°
Potenza ammissibile in % della potenza nominale / Permitted power as a % of rated power Zulässige Leistung in % der Nennleistung / Puissance admissible en % de la puissance nominale	100%	95%	90%	85%	80%

Quando è richiesto un declassamento del motore superiore al 15%, contattare il ns. Servizio Tecnico.

*Should a derating factor higher than 15% apply please consult factory.*

Wenn eine Motordeklassierung höher als 15% gefragt ist, wir bitten um Rückfrage.

*Si un déclassement du moteur supérieur à 15% est requis, on devra contacter notre Service Technique.*

#### Classe d'isolamento

#### Insulation class

#### Isolationsklasse

#### Classes d'isolation

### CL F

I motori di produzione Bonfiglioli impiegano, di serie, materiali isolanti (filo smaltato, isolanti, resine d'impregnazione) in classe F.

*Bonfiglioli motors use class F insulating materials (enamelled wire, insulators, impregnation resins) as compare to the standard motor.*

Die Motoren von Bonfiglioli sind serienmäßig mit Isolierstoffen (Emaildraht, Isolierstoffen, Imprägnierharzen) der Klasse F ausgestattet.

*De série, les moteurs fabriqués par Bonfiglioli utilisent des matériaux isolants (fil émaillé, isolants, résines d'impregnation) en classe F.*

### CL H

Su richiesta può venire specificata la classe di isolamento H.  
In genere, per i motori in esecuzione standard la sovratemperatura dell'avvolgimento statore è contenuta entro il limite di 80 K, corrispondente alla sovratemperatura di classe B.

*Motors manufactured in insulation class H are available at request.  
In standard motors, stator windings over temperature normally stays below the 80 K limit corresponding to class B over temperature.*

Auf Anfrage können sie auch in der Klasse H geliefert werden.  
Allgemein hält sich die Übertemperatur der Motoren in der Standardausführung innerhalb des Grenzwerts von 80 K, der einer Übertemperatur der Klasse B entspricht.

*Sur demande, la classe d'isolation H peut être spécifiée.  
En général, pour les moteurs en exécution standard, l'échauffement de l'enroulement du stator se situe dans la limite de 80 K, correspondant à un échauffement de classe B.*

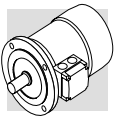

L'accurata scelta dei componenti del sistema isolante consente l'impiego dei motori anche in climi tropicali ed in presenza di vibrazioni normali.

Per applicazioni in presenza di sostanze chimiche aggressive, o di elevata umidità, è consigliabile contattare il Servizio Tecnico Bonfiglioli per la selezione del prodotto più idoneo.

*A careful selection of insulating components makes the motors compatible with tropical climates and normal vibration.*

*For applications involving the presence of aggressive chemicals or high humidity, contact Bonfiglioli Engineering for assistance with product selection.*

Die sorgfältig Wahl der Komponenten des Isoliersystem gestatten den Einsatz dieser Motoren auch unter tropischen Klimabedingungen und bei Vorliegen normaler Schwingungen.

Für den Einsatz in in der Nähe aggressiv wirkenden chemischen Substanzen oder bei hoher Luftfeuchtigkeit, wird empfohlen sich zur Wahl eines passenden Produktes mit unserem Technischen Kundendienst in Verbindung zu setzen.

*Le choix soigné des composants du système d'isolation permet d'utiliser également les moteurs dans des climats tropicaux et en présence de vibrations normales.*

*Pour des applications en présence de substances chimiques agressives, ou d'humidité élevée, il est conseillé de contacter le Service Technique Bonfiglioli pour sélectionner le produit le plus adapté.*

(A43)

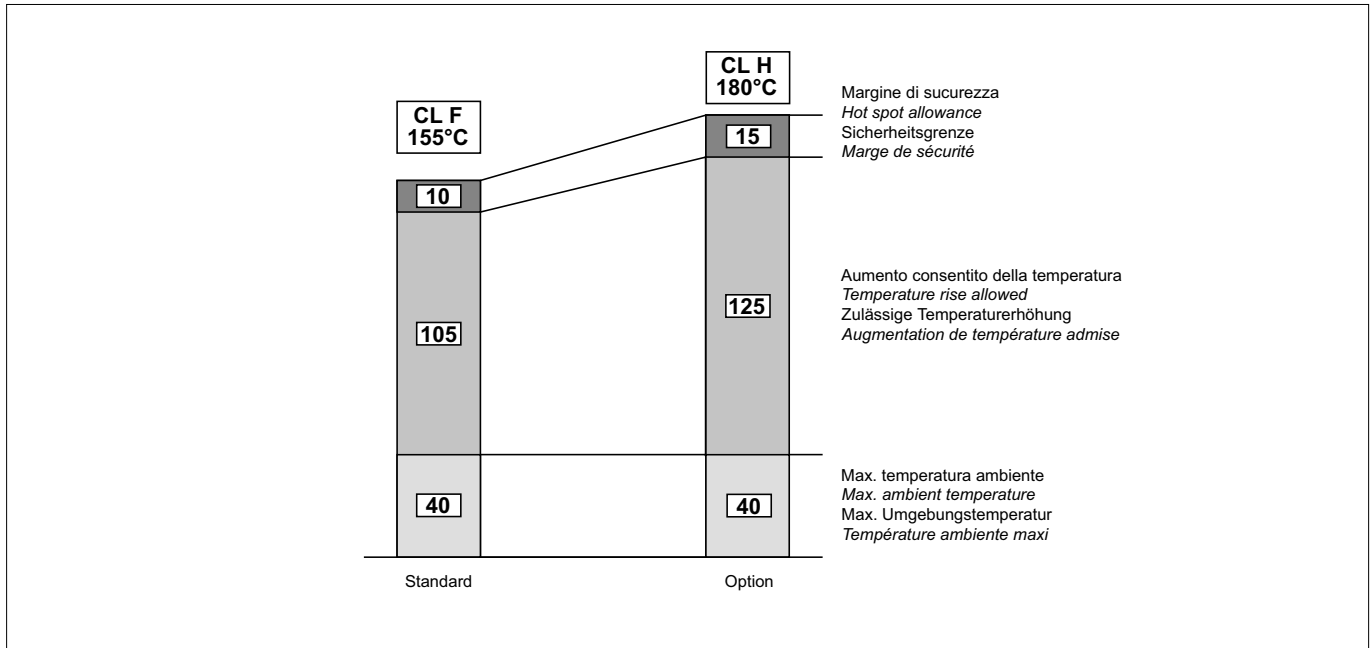

**Tipo di servizio**

Se non indicato diversamente la potenza dei motori riportata a catalogo si riferisce al servizio continuo S1.

Per i motori utilizzati in condizioni diverse da S1 sarà necessario identificare il tipo di servizio previsto con riferimento alle Norme CEI EN 60034-1.

In particolare, per i servizi S2 ed S3, è possibile ottenere una maggiorazione della potenza termica rispetto a quella prevista per il servizio continuo secondo quanto indicato nella tabella (A44) valida per motori ad una velocità. Per motori a doppia polarità interpellare il nostro Servizio Tecnico.

**Type of duty**

*Unless otherwise indicated, the power of motors specified in the catalogue refers to continuous duty S1.*

*For motors used under conditions other than S1, the type of duty required must be adjusted with reference to CEI EN 60034-1 Standards.*

*In particular, for duties S2 and S3, power can be adjusted with respect to continuous duty according to data in table (A44) applicable to single speed motors. For double speed motors, contact our Technical Service.*

**Betriebsart**

Sofern nicht anders angegeben, bezieht sich die im Katalog angegebene Motorleistung auf den Dauerbetrieb S1.

Bei den Motoren, die für eine andere Betriebsart als S1 vorgesehen sind, muß man die Betriebsart unter Bezugnahme auf die Normen CEI EN 60034-1 identifizieren.

Insbesondere kann man für die Betriebsarten S2 und S3 nach der für Motoren mit einer Drehzahl. Gültigen Tabelle (A44) eine Überdimensionierung der Leistung für den Dauerbetrieb im Vergleich zur vorgesehenen Betriebsart erreichen. Für polumschaltbaren Motoren, bitte Rückfrage.

**Type de service**

*sauf indication contraire, la puissance des moteurs reportée dans le catalogue se réfère au service continu S1.*

*Pour les moteurs utilisés dans des conditions différentes de S1, il sera nécessaire d'identifier le type de service prévu en se référant aux normes CEI EN 60034-1.*

*En particulier, pour les services S2 et S3, il est possible d'obtenir une majoration de la puissance par rapport à celle prévue pour le service continu selon ce qui est indiqué dans le tableau (A44) valable pour les moteurs à une vitesse. Pour les moteurs à double polarité, contacter notre Service Technique.*

(A44)

	Servizio / Duty / Betriebsart / Service						
	S2			S3 *			S4 - S9
	Durata del ciclo (min) / Cycle duration (min) / Zyklusdauer (min) / Durée du cycle (min)			Rapporto di intermittenza (I) / Cyclic duration factor (I) / Relative Einschaltdauer (I) / Rapport d'intermittence (I)			Interpellarci / Consult factory / Rückfrage / Nous contacter
	10	30	60	25%	40%	60%	
f <sub>m</sub>	1.35	1.15	1.05	1.25	1.15	1.1	

\* La durata del ciclo dovrà comunque essere uguale o inferiore a 10 minuti; se superiore interpellare il nostro Servizio Tecnico.

*\* Cycle duration must, in any event, be equal to or less than 10 minutes; if this time is exceeded, please contact our Technical Service.*

\* Die Zyklusdauer muß in jedem Fall kleiner oder gleich 10 Minuten sein. Wenn sie darüber liegt, unseren Technischen Kundendienst zu Rate ziehen.

*\* La durée du cycle devra être inférieure ou égale à 10 minutes. Si supérieure, contacter notre Service Technique.*

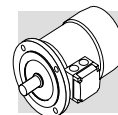

Rapporto di intermittenza:

Cyclic duration factor:

Relative Einschaltdauer:

Rapport d'intermittence:

$$I = \frac{t_f}{t_f + t_r} \cdot 100$$

(23)

$t_f$  = tempo di funzionamento a carico costante  
 $t_r$  = tempo di riposo

$t_f$  = work time under constant load  
 $t_r$  = rest time

$t_f$  = Betriebszeit mit konstanter Last  
 $t_r$  = Aussetzzeit

$t_f$  = temps de fonctionnement à charge constante  
 $t_r$  = temps de repos

### Servizio di durata limitata S2

### Limited duration duty S2

### Kurzzeitbetrieb S2

### Service de durée limitée S2

Caratterizzato da un funzionamento a carico costante per un periodo di tempo limitato, inferiore a quello richiesto per raggiungere l'equilibrio termico, seguito da un periodo di riposo di durata sufficiente a ristabilire, nel motore, la temperatura ambiente.

*This type of duty is characterized by operation at constant load for a limited time, which is shorter than the time required to reach thermal equilibrium, followed by a rest period of sufficient duration to restore ambient temperature in the motor.*

Betrieb mit konstanter Last für eine begrenzte Zeit, die unter der Zeit liegt, die zum Erreichen des thermischen Gleichgewichts benötigt wird, gefolgt von einer Aussetzzeit, die so lang ist, daß der Motor wieder auf die Umgebungstemperatur abkühlen kann.

*Caractérisé par un fonctionnement à charge constante pour une période de temps limitée, inférieure à celle nécessaire pour atteindre l'équilibre thermique, suivie par une période de repos de durée suffisante pour rétablir, dans le moteur, la température ambiante.*

### Servizio intermittente periodico S3:

### Periodical intermittent duty S3:

### Periodische Einschaltdauer S3:

### Service intermittent périodique S3

Caratterizzato da una sequenza di cicli di funzionamento identici, ciascuno comprendente un periodo di funzionamento a carico costante ed un periodo di riposo. In questo servizio, la corrente di avviamento non influenza la sovratemperatura in modo significativo.

*This type of duty is characterized by a sequence of identical operation cycles, each including a constant load operation period and a rest period. For this type of duty, the starting current does not significantly influence overtemperature.*

Betrieb mit aufeinanderfolgenden identischen Betriebszyklen, die alle einen kurzzeitigen Betrieb mit konstanter Belastung und eine Aussetzzeit einschließen. Bei dieser Betriebsart beeinflusst der Anlaufstrom die Überetemperatur nicht in signifikanter Weise.

*Caractérisé par une séquence de cycles de fonctionnement identiques, comprenant chacun une période de fonctionnement à charge constante et une période de repos. Dans ce service, le courant de démarrage n'influence pas l'excès de température de façon significative.*

### Funzionamento con alimentazione da inverter

### Inverter-controlled motors

### Betrieb mit Versorgung über Inverter

### Fonctionnement avec alimentation par variateur de vitesse

I motori elettrici della serie BN ed M possono essere utilizzati con alimentazione da inverter PWM, e tensione nominale all'ingresso del convertitore fino a 500 V.

*The electric motors of series BN and M may be used in combination with PWM inverters with rated voltage at transformer input up to 500 V. Standard motors use a phase insulating system with separators, class 2 enamelled wire and class H impregnation resins (1600V peak-to-peak voltage pulse capacity and rise edge  $t_s > 0.1\mu s$  at motor terminals). Table (A54) shows the typical torque/speed curves referred to S1 duty for motors with base frequency  $f_b = 50$  Hz.*

Die Elektromotoren der Serie BN und M können über einen Inverter PWM und mit einer Nennspannung am Wandlereingang bis zu 500 V versorgt werden. Das an den Serienmotoren angewendete System sieht eine Phasenisolierung mittels Trennvorrichtungen vor, ebenso wie einen Emailldraht mit Grad 2 und Imprägnierungsharze in der Klasse H vor (Abdichtungsgrenze bei Spannungsimpuls 1600V Spitze-Spitze und Anstiegsfront  $t_s > 0.1\mu s$  an den Motorklemmen). Die typischen Merkmale von Drehmoment/Geschwindigkeit im Betrieb S1 für Motoren mit einer Grundfrequenz  $f_b = 50$  Hz werden in der Tab. (A54) angegeben. Bei Betriebsfrequenzen unter ungefähr 30 Hz müssen die selbstlüftenden Standardmotoren (IC411) aufgrund der in diesem Fall abnehmenden Belüftung entsprechend paarweise deklassiert, oder in Alternative, mit unabhängigen Servoventilatoren ausgestattet werden. Bei über der Grundfrequenz liegenden Frequenzen arbeitet der Motor,

*Les moteurs électriques de la série BN et M peuvent être utilisés avec alimentation par variateur PWM, et tension nominale en entrée du convertisseur jusqu'à 500V. Le système adopté sur les moteurs de série prévoit l'isolation de phase avec des séparateurs, l'utilisation de fil émaillé niveau 2 et résines d'imprégnation de classe H (limite de maintien à l'impulsion de tension 1600V pic-pic et front de montée  $t_s > 0.1\mu s$  aux bornes moteur). Les caractéristiques typiques couple/vitesse en service S1 pour moteur avec fréquence de base  $f_b = 50$  Hz sont indiquées dans le tab. (A54).*

Il sistema isolante sui motori di serie prevede l'isolamento di fase con separatori, l'utilizzo di filo smaltato in grado 2 e resine d'imprégnazione in classe H (limite di tenuta all'impulso di tensione 1600V picco-picco e fronte di salita  $t_s > 0.1\mu s$  ai morsetti motore).

*Because ventilation is somewhat impaired in operation at lower frequencies (about 30 Hz), standard motors with incorporated fan (IC411) require adequate torque derating or - alternately - the addition of a separate supply fan cooling. Above base frequency, upon reaching the maximum output voltage of the inverter, the motor enters a steady-power field of operation, and shaft torque drops with ratio  $(f/f_b)$ .*

*Pour des fréquences de fonctionnement inférieures à environ 30 Hz, à cause de la diminution de la ventilation, les moteurs standards autoventilés (IC411) doivent être opportunément déclassés au niveau du couple ou, en alternative, doivent être équipés de servoventilateur indépendant. Pour des fréquences supérieures à la fréquence de base, une fois*

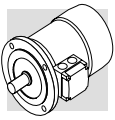

campo di funzionamento a potenza costante, con coppia all'albero che si riduce ca. con il rapporto  $(f/f_b)$ . Poiché la coppia massima del motore decresce ca. con  $(f/f_b)^2$ , il margine di sovraccarico ammesso dovrà essere progressivamente ridotto.

*As motor maximum torque decreases with  $(f/f_b)^2$ , the allowed overloading must be reduced progressively.*

nach Erreichen des max. Spannungswerts am Inverterausgang in einem Betriebsbereich unter konstanter Leistung mit einem Drehmoment an der Welle, der sich ungefähr im Verhältnis  $(f/f_b)$  reduziert. Da das max. Drehmoment des Motors mit ungefähr  $(f/f_b)^2$  abnimmt, muss auch der zulässige Überbelastungsgrenzwert progressiv reduziert werden.

*la valeur maximale de tension de sortie du variateur atteinte, le moteur fonctionne dans une plage de fonctionnement à puissance constante, avec couple à l'arbre qui se réduit avec le rapport  $(f/f_b)$ . Dans la mesure où le couple maximal du moteur diminue avec  $(f/f_b)^2$ , la marge de surcharge admise doit être progressivement réduite.*

(A45)

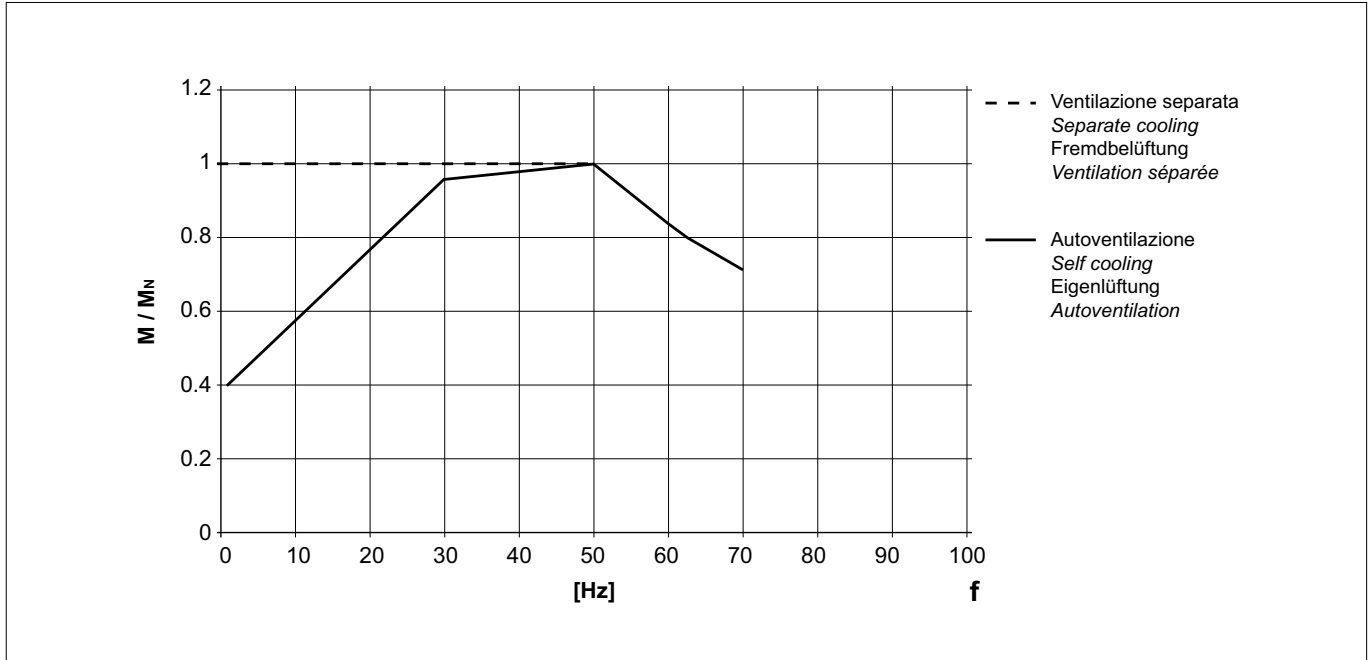



Per funzionamento oltre la frequenza nominale, la velocità limite meccanica dei motori è riportata in tabella (A45):

*Table (A45) reports the mechanical limit speed for motor operation above rated frequency:*

Für einen Betrieb, der über die Nennfrequenz hinausgeht, wird die Geschwindigkeitsbegrenzung der Motoren in der Tabelle (A45) angegeben:

*En cas de fonctionnement au-delà de la fréquence nominale, la vitesse limite mécanique des moteurs est indiquée dans le tableau (A45):*

(A46)

		n [min <sup>-1</sup> ]		
		2p	4p	6p
≤ BN 112	M05...M3	5200	4000	3000
BN 132...BN 200L	M4, M5	4500	4000	3000

A velocità superiori alla nominale i motori presentano maggiori vibrazioni meccaniche e rumorosità di ventilazione; è consigliabile, per queste applicazioni, un bilanciamento del rotore in grado R e l'eventuale montaggio del servoventilatore indipendente.

*Above rated speed, motors generate increased mechanical vibration and fan noise. Class R rotor balancing is highly recommended in these applications. Installing a separate supply fan cooling may also be advisable.*

Bei Geschwindigkeiten über die Nennwerte hinaus, weisen die Motoren höhere mechanische Schwingungen und mehr Funktionsgeräusche bei der Belüftung auf. Bei diesen Applikationen wird ein Auswuchten des Rotors im Grad R und eine eventuelle Montage des unabhängig funktionierenden Servoventilators empfohlen.

*A des vitesses supérieures à la vitesse nominale, les moteurs présentent plus de vibrations mécaniques et de bruit de ventilation ; pour ces applications, il est conseillé d'effectuer un équilibrage du rotor en niveau R et de monter éventuellement un servoventilateur indépendant.*

Il servoventilatore e, se presente, il freno elettromagnetico devono sempre essere alimentati direttamente da rete.

*Remote-controlled fan and brake (if fitted) must always be connected direct to mains power supply.*

Der Servoventilator und, falls vorhanden, die elektromagnetische Bremse müssen immer direkt über das Netz gespeist werden.

*Le servoventilateur et, si présent, le frein électromagnétique doivent toujours être alimentés directement par le réseau.*

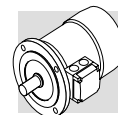

### Frequenza massima di avviamento Z

Nelle tabelle dei dati tecnici motori è indicata la max frequenza di inserzione a vuoto  $Z_0$  con  $I = 50\%$  riferita alla versione autofrenante. Questo valore definisce il numero max di avviamenti orari a vuoto che il motore può sopportare senza superare la max temperatura ammessa dalla classe di isolamento F.

Nel caso pratico di motore accoppiato ad un carico esterno con potenza assorbita  $P_r$ , massa inerziale  $J_c$  e coppia resistente media durante l'avviamento  $M_L$ , il numero di avviamenti ammissibile si può calcolare in modo approssimato con la seguente formula:

### Permissible starts per hour, Z

The rating charts of brakemotors lend the permitted number of starts  $Z_0$ , based on 50% intermittence and for unloaded operation.

The catalogue value represents the maximum number of starts per hour for the motor without exceeding the rated temperature for the insulation class F.

To give a practical example for an application characterized by inertia  $J_c$ , drawing power  $P_r$  and requiring mean torque at start-up  $M_L$  the actual number of starts per hour for the motor can be calculated approximately through the following equation:

### Maximale Schaltungshäufigkeit Z

In den Tabellen mit den Technischen Daten der Motoren ist die maximale Schaltungshäufigkeit im Leerlauf  $Z_0$  bei relativer Einschaltdauer  $I = 50\%$  bezüglich auf die Bremsausführung. Dieser Wert definiert die maximale Anzahl von Anfahrten im Leerlauf pro Stunde, die der Motor ertragen kann, ohne die durch die Isolierstoffklasse F festgelegte maximal zulässige Temperatur zu überschreiten.

Im praktischen Fall eines mit einer externen Last verbundenen Motors mit einer Leistungsaufnahme von  $P_r$ , Trägheitsmasse  $J_c$  und mittlerem Gegenmoment während des Anfahrens von  $M_L$  kann die zulässige Anzahl Anfahrten mit folgender Formel approximativ berechnet werden:

### Fréquence maximum de démarrage Z

Dans les tableaux des caractéristiques techniques des moteurs se trouve la fréquence maximum d'insertion à vide  $Z_0$  avec intermittence  $I = 50\%$  référée à la version frein. Cette valeur définit un nombre maximum de démarrages horaires à vide que le moteur peut supporter sans dépasser la température maximum admise par la classe d'isolation F.

Dans le cas pratique de moteur accouplé à une charge extérieure avec puissance absorbée  $P_r$ , masse inertielle  $J_c$  et couple résistant moyen pendant le démarrage  $M_L$ , le nombre de démarrages admissible peut se calculer de façon approximative avec la formule suivante:

$$Z = \frac{Z_0 \cdot K_c \cdot K_d}{K_J}$$

dove:

$$K_J = \frac{J_m + J_c}{J_m} = \text{fattore di inerzia}$$

$$K_c = \frac{M_a - M_L}{M_a} = \text{fattore di coppia}$$

$K_d$  = fattore di carico  
vedi tabella (A46)

where:

$$K_J = \frac{J_m + J_c}{J_m} = \text{inertia factor}$$

$$K_c = \frac{M_a - M_L}{M_a} = \text{torque factor}$$

$K_d$  = load factor  
see table (A46)

wobei gilt:

$$K_J = \frac{J_m + J_c}{J_m} = \text{Trägheitsfaktor}$$

$$K_c = \frac{M_a - M_L}{M_a} = \text{Drehmomentsfaktor}$$

$K_d$  = Lastfaktor  
siehe Tabelle (A46)

où:

$$K_J = \frac{J_m + J_c}{J_m} = \text{facteur d'inertie}$$

$$K_c = \frac{M_a - M_L}{M_a} = \text{facteur de couple}$$

$K_d$  = facteur de charge  
voir tableau (A46)

(A47)

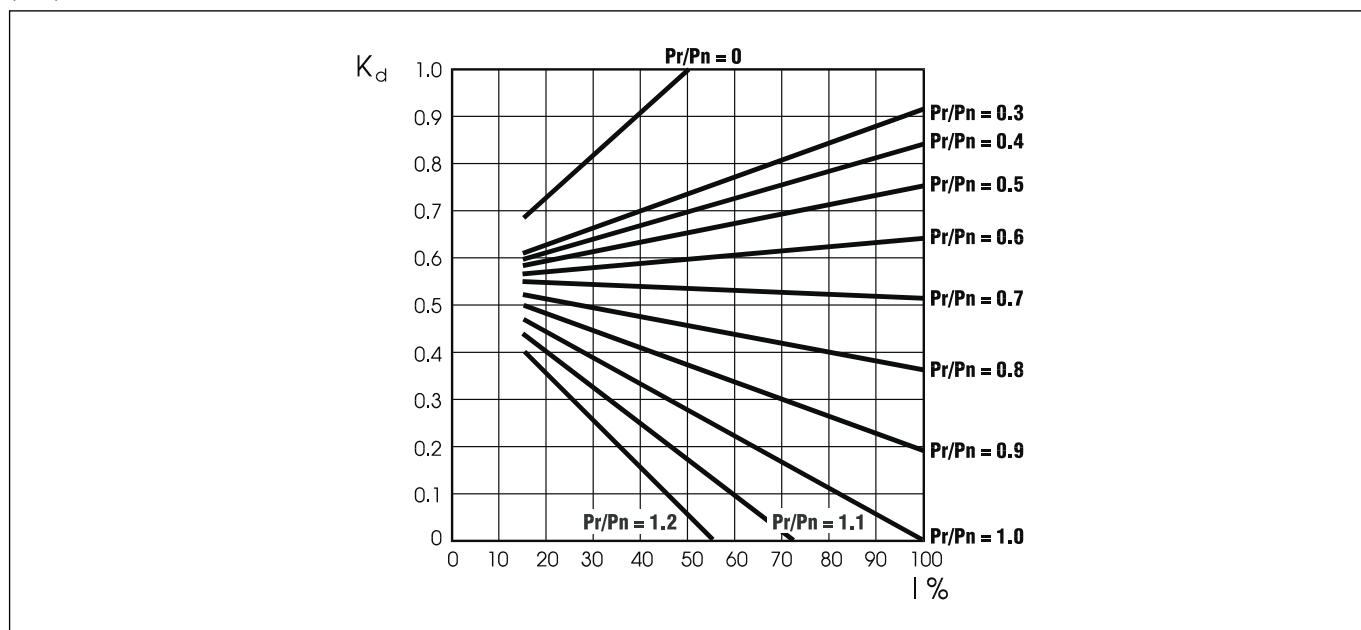

Con il numero di avviamenti così ottenuto si dovrà in seguito verificare che il massimo lavoro di frenatura sia compatibile con la capacità termica del freno  $W_{max}$  indicata nella tabella (A54).

If actual starts per hour is within permitted value (Z) it may be worth checking that braking work is compatible with brake (thermal) capacity  $W_{max}$  also given in table (A54) and dependent on the number of switches (c/h).

Auf Grundlage der so berechneten Anzahl Schaltungen muß man dann prüfen, ob die maximale Bremsarbeit mit der Wärmegrenzleistung der Bremse  $W_{max}$  kompatibel ist, die in die Tabelle (A54) angegeben ist.

Avec le nombre de démarrages ainsi obtenu, il faudra ensuite vérifier que le travail maximum de freinage soit compatible avec la capacité thermique du frein  $W_{max}$  indiquée dans le table (A54).



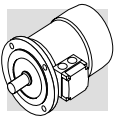

## M5 - MOTORI ASINCRONI AUTOFRENANTI

## M5 - ASYNCHRONOUS BRAKE MOTORS

## M5 - DREHSTROMBREMS- MOTOREN

## M5 - MOTEURS FREIN ASYNCHRONES

### Funzionamento

L'esecuzione autofrenante prevede l'impiego di freni a pressione di molle alimentati in c.c. (tipo FD) o in c.a. (tipo FA, BA). Tutti i freni funzionano secondo il principio di sicurezza, ossia intervengono in seguito alla pressione esercitata dalle molle, in mancanza di alimentazione.

### Operation

Versions with incorporated brake use spring-applied DC (FD option) or AC (FA, BA options) brakes. All brakes are designed to provide fail-safe operation, meaning that they are applied by spring-action in the event of power failure.

### Betriebsweise

Die selbstbremsende Ausführung der Motoren sieht den Einsatz von Federdruckbremsen vor, die mit Gleichstrom (Typ FD) oder mit Wechselstrom (Typ FA, BA) gespeist werden. Alle Bremsen arbeiten gemäß dem Sicherheitsprinzip, d.h. sie greifen, im Fall eines Stromausfalls in Folge eines auf die Feder ausgeübten Drucks ein.

### Fonctionnement

L'exécution avec frein prévoit l'utilisation de freins à pression de ressorts alimentés en c.c. (type FD) ou en c.a. (type FA, BA). Tous les freins fonctionnent selon le principe de sécurité, c'est-à-dire qu'ils interviennent suite à la pression exercée par les ressorts, en cas de coupure d'alimentation.

(A48)

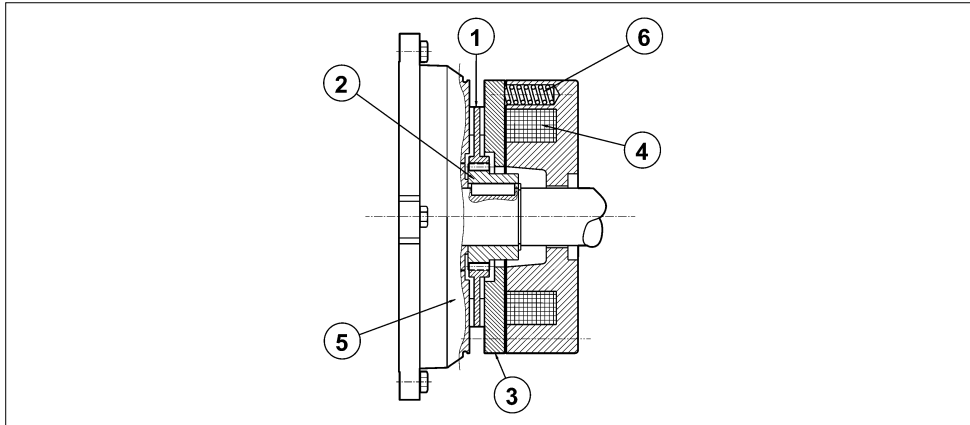

### Legenda:

- ① disco
- ② mozzo
- ③ áncora mobile
- ④ bobina
- ⑤ scudo post.motore
- ⑥ molle

### Key:

- ① brake disc
- ② disc carrier
- ③ pressure plate
- ④ brake coil
- ⑤ motor rear shield
- ⑥ brake springs

### Zeichenerklärung:

- ① Brems scheinbe
- ② Nabe
- ③ Beweglicher Anker
- ④ Ringspule
- ⑤ Motorschild
- ⑥ Schußfedern

### Légende:

- ① disque
- ② moyeu d'entraînement
- ③ disque de freinage
- ④ bobine de frein
- ⑤ flasque-frein
- ⑥ ressort de frein

In mancanza di tensione, l'ancora mobile spinta dalle molle di pressione blocca il disco freno tra la superficie dell'ancora stessa e lo scudo motore impedendo la rotazione dell'albero. Quando la bobina viene eccitata, l'attrazione magnetica esercitata sull'ancora mobile vince la reazione elastica delle molle e libera il disco freno, e conseguentemente l'albero motore con esso solidale.

When voltage is interrupted, pressure springs push the armature plate against the brake disc. The disc becomes trapped between the armature plate and motor shield and stops the shaft from rotation. When the coil is energized, a magnetic field strong enough to overcome spring action attracts the armature plate, so that the brake disc - which is integral with the motor shaft - is released.

Wenn die Spannungsversorgung abfällt, sorgt der bewegliche, von den Druckfedern geschobene Anker für die Blockierung der Bremsscheibe zwischen der Ankerfläche und dem Motorschild und blockiert damit den Rotor. Wird die Spule erregt, kommt es durch den magnetischen auf den beweglichen Anker wirkenden Anzug zur Überwindung der elastischen Federkraft und zum Lösen der Bremsscheibe, wodurch der rotor wieder freigegeben wird.

En cas de coupure de courant, l'armature mobile, poussée par les ressorts, bloque le disque de frein entre la surface de l'armature et le bouclier moteur en empêchant la rotation de l'arbre. Lorsque la bobine est excitée, l'attraction magnétique exercée sur l'armature mobile annule la réaction élastique des ressorts et libère le disque de frein, et par conséquent l'arbre moteur, qui est solidaire.

### Caratteristiche generali

- Coppie frenanti elevate (generalmente  $M_b \approx 2 M_n$ ) e regolabili.
- Disco freno con anima in acciaio a doppia guarnizione d'attrito (materiale a bassa usura, senza amianto).
- Cava esagonale sull'albero motore, lato ventola (N.D.E.), per rotazione manuale (non prevista quando sono presenti le opzioni PS, RC, TC, U1, U2, EN1, EN2, EN3).
- Sblocco meccanico manuale.
- Trattamento anticorrosivo di tutte la superfici del freno.
- Isolamento in classe F

### Most significant features

- High braking torques (normally  $M_b \approx 2 M_n$ ), braking torque adjustment.
- Steel brake disc with double friction lining (low-wear, asbestos-free lining).
- Hexagonal seat on motor shaft fan end (N.D.E.) for manual rotation (not compatible with options PS, RC, TC, U1, U2, EN1, EN2, EN3).
- Manual release lever.
- Corrosion-proof treatment on all brake surfaces.
- Insulation class F

### Allgemeine Eigenschaften

- Hohe und regulierbare Bremsmomente (allgemein  $M_b \approx 2 M_n$ ).
- Bremsscheibe mit Stahlkern und doppeltem Bremsbelag (Material mit geringem Verschleiß, asbestfrei).
- Sechskant hinten an der Motorwelle, auf Lüfterradseite (N.D.E.), für eine manuelle Drehung des Rotors mit einem Inbusschlüssel. (nicht lieferbar, wenn die Optionen PS, RC, TC, U1, U2, EN1, EN2, EN3) bestellt wurden.
- Manuell zu betätigende, mechanische Bremslüftvorrichtung.
- Korrosionsschutzbehandlung an allen Flächen der Bremse.
- Isolierung in Klasse F

### Caractéristiques générales

- Couples de freinage élevés (généralement  $M_b \approx 2 M_n$ ) et réglables.
- Disque de frein avec structure en acier à double garniture de frottement (matière à faible usure, sans amiante).
- Empreinte hexagonale sur l'arbre moteur, côté ventilateur (N.D.E.), pour la rotation manuelle (non prévue en cas de présence des options PS, RC, TC, U1, U2, EN1, EN2, EN3).
- Déblocage mécanique manuel.
- Traitement anticorrosion sur toute la surface du frein.
- Isolation en classe F

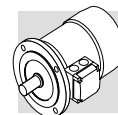

**M6 - MOTORI AUTOFRENANTI  
IN C.C., TIPO BN\_FD**

**M6 - DC BRAKE MOTORS  
TYPE BN\_FD**

**M6 - DREHSTROMBREMSMO-  
TOREN MIT GLEICH-  
STROMBREMSE: TYP  
BN\_FD**

**M6 - MOTEURS FREIN EN C.C.,  
TYPE BN\_FD**

**Grandezze:** BN 63 ... BN 200L

**Frame sizes:** BN 63 ... BN 200L

**Baugrößen:** BN 63 ... BN 200L

**Tailles :** BN 63 ... BN 200L

(A49)

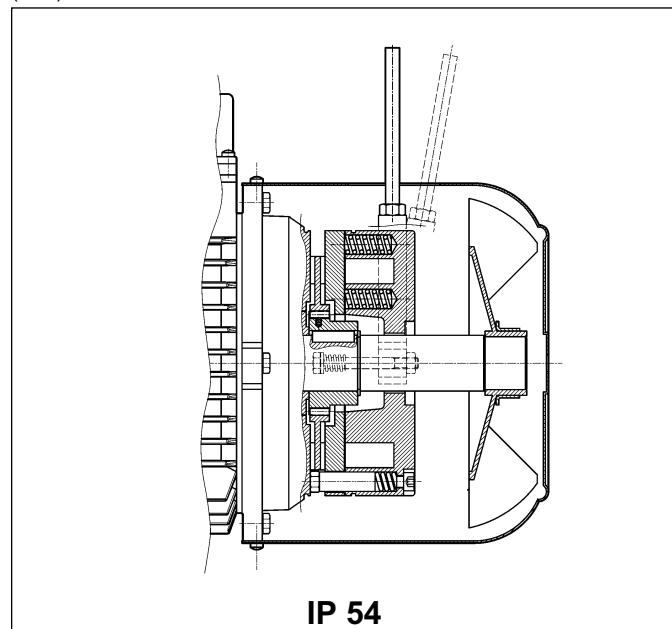

**IP 54**

(A50)

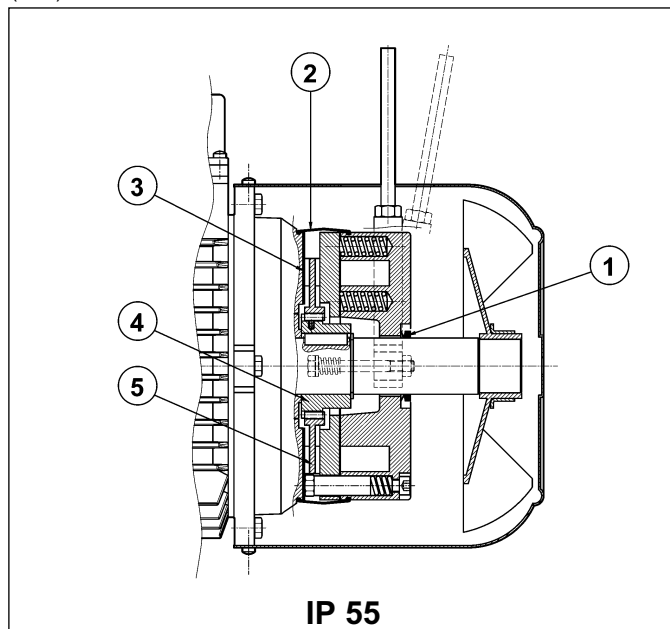

**IP 55**

Freno elettromagnetico con bobina toroidale in **corrente continua** fissato con viti allo scudo motore; le molle di precarico realizzano il posizionamento assiale del corpo magnete.

Il disco freno è scorrevole sul mozzo trascinatore in acciaio calettato sull'albero e previsto di molla antivibrazione.

I motori sono forniti con freno tarato in fabbrica al valore di coppia riportato nelle tabelle dati tecnici; la coppia frenante può essere regolata modificando il tipo e/o il numero delle molle.

A richiesta, i motori possono essere previsti di leva per lo sblocco manuale con ritorno automatico (**R**) o con mantenimento della posizione di rilascio freno (**RM**); per la posizione angolare della leva di sblocco vedi descrizione della relativa variante alla pag. 174.

Il freno FD garantisce elevate prestazioni dinamiche e bassa rumorosità; le caratteristiche d'intervento del freno in corrente continua possono essere ottimizzate in funzione dell'applicazione, utilizzando i vari tipi di alimentatore disponibili e/o realizzando l'opportuno cablaggio.

**Direct current toroidal-coil electromagnetic brake bolted onto motor shield.** Preloading springs provide axial positioning of magnet body.

Brake disc slides axially on steel hub shrunk onto motor shaft with anti-vibration spring.

Brake torque factory setting is indicated in the corresponding motor rating charts. Braking torque may be modified by changing the type and/or number of springs.

At request, motors may be equipped with manual release lever with automatic return (**R**) or system for holding brake in the released position (**RM**).

See variant at page 174 for available release lever locations.

FD brakes ensure excellent dynamic performance with low noise. DC brake operating characteristics may be optimized to meet application requirements by choosing from the various rectifier/power supply and wiring connection options available.

Elektromagnetische Bremse mit Ringwicklungsspule für **Gleichstromspannung**, die mittels Schrauben am hinteren Motorschild befestigt ist. Die Federn sorgen für die axiale Ausrichtung des Magnetkörpers.

Die Bremsscheibe gleitet axial auf der Mitnehmernabe aus Stahl, die über eine Paßfeder mit der Motorwelle verbunden und mit einer Schwingungsdämpfung ausgestattet ist.

Die Motoren werden vom Hersteller auf den in der Tabelle der technischen Daten angegebenen Bremsmoment eingestellt; das Bremsmoment kann durch das Ändern des Typs und/oder der Anzahl der Federn reguliert werden.

Auf Anfrage können die Motoren mit einem Bremslüfthebel für die manuelle Lüftung der Bremse mit selbstständiger Rückstellung (**R**) ohne Arretierung oder mit arretierbarem Lüfthebel (**RM**) geliefert werden. Die Festlegung der Position des Bremslüfthebel in Abhängigkeit von der Klemmkastenlage erfolgt durch die Option auf Seite 174.

Die Bremse vom Typ FD garantiert hohe dynamische Leistungen und niedrige Laufgeräusche. Die Ansprechigenschaften der Bremse unter Gleichstrom können in Abhängigkeit zur jeweiligen Anwendung durch den Einsatz der verschiedenen verfügbaren Gleichrichter oder durch eine entsprechenden Anschluß der Bremse optimiert werden.

Frein électromagnétique avec bobine toroïdale en **courant continu**, fixé avec des vis au bouclier moteur; les ressorts de précharge réalisent le positionnement axial de la bobine.

Le disque frein coulisse de façon axiale sur le moyeu d'entraînement en acier calé sur l'arbre et doté de ressort antivibration.

Les moteurs sont fournis avec frein pré-réglé en usine à la valeur de couple indiquée dans les tableaux des caractéristiques techniques; le couple de freinage peut être réglé en modifiant le type et/ou le nombre de ressorts.

Sur demande, les moteurs peuvent être équipés de levier pour le déblocage manuel avec retour automatique (**R**) ou avec maintien de la position de déblocage frein (**RM**); pour la position angulaire du levier de déblocage, voir description de la variante correspondante à la page 174.

Le frein FD garantit des performances dynamiques élevées et un faible niveau de bruit; les caractéristiques d'intervention du frein en courant continu peuvent être optimisées en fonction de l'application en utilisant les différents types de dispositifs d'alimentation disponibles et/ou en réalisant un câblage approprié.

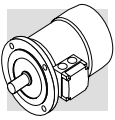

### Grado di protezione

L'esecuzione standard prevede il grado di protezione IP54. In opzione il motore autofrenante tipo FD viene fornito con grado di protezione **IP 55**, prevedendo le seguenti varianti costruttive:

- ① anello V-ring posizionato sull'albero motore N.D.E.
- ② fascia di protezione in gomma
- ③ anello in acciaio inox interposto tra scudo motore e disco freno
- ④ mozzo trascinatore in acciaio inox
- ⑤ disco freno in acciaio inox

### Degree of protection

Standard protection class is IP54.

Brake motor FD is also available in protection class **IP 55**, which mandates the following variants:

- ① V-ring at N.D.E. of motor shaft
- ② dust and water-proof rubber boot
- ③ stainless steel ring placed between motor shield and brake disc
- ④ stainless steel hub
- ⑤ stainless steel brake disc

### Schutzart

Die Standardausführung ist Schutzart IP54 vor. Optional kann der Bremsmotor vom Typ FD in der Schutzart **IP 55** geliefert werden, wobei sind folgende Komponenten eingesetzt werden:

- ① V-Ring an der Motorwelle N.D.E.
- ② Schutzring aus Gummi
- ③ Ring aus rostfreiem Stahl zwischen Motorschild und
- ④ Bremsscheibe Mitnehmer-nabe aus rostfreiem Stahl
- ⑤ Bremsscheibe aus rostfreiem Stahl

### Degré de protection

L'exécution standard prévoit le degré de protection IP54.

En option, le moteur frein type FD est fourni avec degré de protection **IP 55**, en prévoyant les variantes de construction suivantes :

- ① bague V-ring positionnées sur l'arbre moteur N.D.E.
- ② bande de protection en caoutchouc
- ③ bague en acier inox interposée entre le bouclier moteur et le disque de frein
- ④ moyeu d'entraînement en acier inox
- ⑤ disque frein en acier inox

### Alimentazione freno FD

L'alimentazione della bobina freno in c.c. è prevista per mezzo di opportuno raddrizzatore montato all'interno della scatola coprimorsetti e già cablato alla bobina del freno.

Per motori a singola polarità è inoltre previsto di serie il collegamento del raddrizzatore alla morsettiera motore.

Indipendentemente dalla frequenza di rete, la tensione standard di alimentazione del raddrizzatore  $V_B$  ha il valore indicato nella tabella (A51) qui di seguito:

### FD brake power supply

A rectifier accommodated inside the terminal box feeds the DC brake coil. Wiring connection across rectifier and brake coil is performed at the factory.

On all single-pole motors, rectifier is connected to the motor terminal board.

Rectifier standard power supply voltage  $V_B$  is as indicated in the following table (A51), regardless of mains frequency:

### Spannungsversorgung der Bremse FD

Die Versorgung der Gleichstrombremsspule erfolgt über einen Gleichrichter im Klemmenkasten der bei Lieferung, wenn nicht anders bestellt, bereits mit der Bremsspule verkabelt ist.

Bei den einpoligen Motoren ist serienmäßig der Anschluss des Gleichrichters an die Motorspannung vorgesehen. Unabhängig von der Netzfrequenz erfolgt die Versorgung des Gleichrichters  $V_B$  über die in der nachstehenden Tabelle (A51) angegebenen Standardspannung:



### Alimentation frein FD

L'alimentation de la bobine de frein en c.c. est prévue au moyen d'un redresseur approprié monté à l'intérieur de la boîte à bornes et déjà câblé à la bobine de frein.

De plus, pour les moteurs à simple polarité, le raccordement du redresseur au bornier moteur est prévu de série.

Indépendamment de la fréquence du réseau, la tension standard d'alimentation du redresseur  $V_B$  correspond à la valeur indiquée dans le tableau (A51) ci-dessous :

(A51)

2, 4, 6 P				1 speed	
		BN_FD / M_FD		alimentazione freno da morsettiera brake connected to terminal board power supply Bremsversorgung über die Motorspannung Alimentation frein depuis boîte à bornes	alimentazione separata separate power supply Separate Versorgung Alimentation séparée
		$V_{mot} \pm 10\%$ 3 ~	$V_B \pm 10\%$ 1 ~		
BN 63...BN 132	M05...M4LB	230/400 V – 50 Hz	230 V	standard	specificare $V_B SA$ o $V_B SD$ specify $V_B SA$ or $V_B SD$ $V_B SA$ oder $V_B SD$ angeben spécifier $V_B SA$ ou $V_B SD$
BN 160...BN 200	M4LC...M5	400/690 V – 50 Hz	400 V	standard	specificare $V_B SA$ o $V_B SD$ specify $V_B SA$ or $V_B SD$ $V_B SA$ oder $V_B SD$ angeben spécifier $V_B SA$ ou $V_B SD$



Per i motori a doppia polarità l'alimentazione standard del freno è da linea separata con tensione d'ingresso al raddrizzatore  $V_B$  come indicato in tabella (A52):

Switch-pole motors feature a separate power supply line for the brake with rectifier input voltage  $V_B$  as indicated in the table (A52):

Die polumschaltbaren Motoren müssen immer mit separater Bremsversorgungsspannung betrieben werden, deshalb erfolgt die Lieferung standardmäßig ohne Anschluß der Bremse an die Motorspannung, da diese mit einer am Eingang des Gleichrichters  $V_B$  anliegenden Spannung versorgt werden muß, entsprechend Werte in der nachstehenden Tabelle (A52):

Pour les moteurs à double polarité, l'alimentation standard du frein dérive d'une ligne séparée avec tension d'entrée au redresseur  $V_B$  comme indiqué dans le tableau (A52):

(A52)

2/4, 2/6, 2/8, 2/12, 4/6, 4/8 P				2 speed	
		BN_FD / M_FD		alimentazione freno da morsettiera brake powered via terminal board Bremsversorgung über die Motorspannung Alimentation frein depuis boîte à bornes	alimentazione separata separate power supply Separate Versorgung Alimentation séparée
		$V_{mot} \pm 10\%$ 3 ~	$V_B \pm 10\%$ 1 ~		
BN 63...BN 132	M05...M4LB	400 V – 50 Hz	230 V		specificare $V_B SA$ o $V_B SD$ specify $V_B SA$ or $V_B SD$ $V_B SA$ oder $V_B SD$ angeben spécifier $V_B SA$ ou $V_B SD$

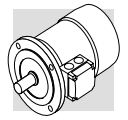

Il raddrizzatore è del tipo a diodi a semionda ( $V_{c.c} \approx 0,45 \times V_{c.a.}$ ) ed è disponibile nelle versioni **NB**, **SB**, **NBR** e **SBR**, come dettagliato nella tabella (A53) seguente:

The diode half-wave rectifier ( $V_{DC} \approx 0,45 \times V_{AC}$ ) is available in versions **NB**, **SB**, **NBR** e **SBR**, as detailed in the table (A53) below:

Bei dem Gleichrichter handelt es sich um einen Typ mit Halbwel-lendioden ( $V_{c.c} \approx 0,45 V_{c.a.}$ ). Er ist in den Versionen **NB**, **SB**, **NBR** und **SBR**, gemäß den Details in der nachstehenden Tabelle (A53), verfügbar:

Le redresseur est du type à diodes à demi-onde ( $V_{c.c} \approx 0,45 \times V_{c.a.}$ ) et il est disponible dans les versions **NB**, **SB**, **NBR** et **SBR**, comme indiqué de façon détaillée dans le tableau (A53) suivant :

(A53)

		freno brake Bremsse frein				
			standard	a richiesta at request auf Anfrage Sur demande		
<b>BN 63</b>	<b>M05</b>	<b>FD 02</b>				
<b>BN 71</b>	<b>M1</b>	<b>FD 03</b>				
		<b>FD 53</b>				
<b>BN 80</b>	<b>M2</b>	<b>FD 04</b>				
<b>BN 90S</b>	—	<b>FD 14</b>				
<b>BN 90L</b>	—	<b>FD 05</b>				
<b>BN 100</b>	<b>M3</b>	<b>FD 15</b>				
—		<b>FD 55</b>				
<b>BN 112</b>	—	<b>FD 06S</b>				
<b>BN 132...160MR</b>	<b>M4</b>	<b>FD 56</b>				
<b>BN 160L - BN 180M</b>	<b>M5</b>	<b>FD 06</b>				
<b>BN 180L - NM 200L</b>	—	<b>FD 07</b>				

(\*)  $t_{2c} < t_{2r} < t_2$

Il raddrizzatore **SB** a controllo elettronico dell'eccitazione, riduce i tempi di sblocco del freno sovraccitando l'elettromagnete nei primi istanti d'inserzione, per passare poi al normale funzionamento a semionda a distacco del freno avvenuto.

Rectifier **SB** with electronic energizing control over-energizes the electromagnet upon power-up to cut brake release response time and then switches to normal half-wave operation once the brake has been released.

Der Gleichrichter **SB** mit elektronischer Kontrolle der Erregung reduziert die Bremslösezeiten, indem er die Bremsspule in den ersten Momenten der Einschaltung übermäßig erregt, um dann, nach erfolgter Bremslösung, in die normale Halbwellenfunktion umzuschalten.

Le redresseur **SB** à contrôle électronique de l'excitation réduit les temps de déblocage du frein en surexcitant l'électro-aimant durant les premiers instants d'enclenchement pour passer ensuite au fonctionnement normal à demi-onde une fois le frein désactivé.

L'impiego del raddrizzatore tipo **SB** è sempre da prevedere nei casi di:

Use of the **SB** rectifier is mandatory in the event of:

Der Einsatz eines Gleichrichters vom Typ **SB** wird in folgenden Fällen empfohlen:

L'utilisation du redresseur type **SB** doit toujours être prévue dans les cas suivants :

- elevato numero di interventi orari
- tempi di sblocco freno ridotti
- elevate sollecitazioni termiche del freno

- high number of operations per hour
- reduced brake release response time
- brake is exposed to extreme thermal stress

- hohe Anzahl von Schaltungen pro Stunde
- schnelle Bremsansprechzeiten
- starke thermische Beanspruchungen der Bremse

- nombre d'interventions horaires élevé
- temps de déblocage frein réduits
- sollicitations thermiques du frein élevées

Per applicazioni dove è richiesto un rapido rilascio del freno sono disponibili a richiesta i raddrizzatori **NBR** o **SBR**.

Rectifiers **NBR** or **SBR** are available for applications requiring quick brake release response.

Für die Anwendungen, bei denen eine schnelle Ansprechzeit der Bremse gefordert wird, können auf Anfrage die Gleichrichter **NBR** oder **SBR** geliefert werden.

Pour les applications nécessitant un déblocage rapide du frein, sur demande les redresseurs **NBR** ou **SBR** sont disponibles.

Questi raddrizzatori completano i tipi **NB** e **SB**, integrando nel cir-

These rectifiers complement the **NB** and **SB** types as their elec-

Diese Gleichrichter erweitern die

Ces redresseurs complètent les types **NB** et **SB**, en intégrant

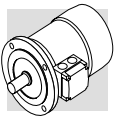

cuito elettronico un interruttore statico che interviene diseccando rapidamente il freno in caso di mancanza di tensione. Questa soluzione consente di ridurre i tempi di rilascio del freno evitando ulteriori cablaggi e contatti esterni. Per il migliore utilizzo dei raddrizzatori **NBR** e **SBR** è richiesta l'alimentazione separata del freno. Tensioni disponibili: 230V ± 10%, 400V ± 10%, 50/60 Hz.

*tronic circuit incorporates a static switch that de-energizes the brake quickly in the event voltage is missing. This arrangement ensures short brake release response time with no need for additional external wiring and contacts. Optimum performance of rectifiers **NBR** and **SBR** is achieved with separate brake power supply. Available voltages: 230V ± 10%, 400V ± 10%, 50/60 Hz.*

Funktion der Typen **NB** und **SB**, indem in dem elektronischen Schaltkreis ein statischen Schalter integriert ist, durch dessen Auslösen die Bremse im Fall eines Spannungsausfalls schnell abgeregt wird. Diese Lösung ermöglicht eine Verringerung der Ansprechzeiten der Bremse, wodurch weitere Schaltungen und externe Sensoren vermieden werden können. Im Hinblick auf einen besseren Einsatz der Gleichrichter **NBR** und **SBR** ist bei der Bremse eine separate Versorgung erforderlich. Verfügbare Spannungen: 230V ± 10%, 400V ± 10%, 50/60 Hz.

*dans le circuit électronique un interrupteur statique qui intervient en désexcitant rapidement le frein en cas de coupure de tension. Cette solution permet de réduire les temps de déblocage du frein en évitant d'autres câblages et contacts extérieurs. Pour une meilleure utilisation des redresseurs **NBR** et **SBR** l'alimentation séparée du frein est nécessaire. Tensions disponibles : 230V ± 10%, 400V ± 10%, 50/60 Hz.*

### Dati tecnici freni FD

Nella tabella (A54) sottostante sono riportati i dati tecnici dei freni in c.c. tipo FD.

(A54)

### FD brake technical specifications

The table (A54) below reports the technical specifications of DC brakes FD.

### Technische Daten - Bremstyp FD

In der nachstehenden Tabelle (A54) werden die technischen Daten der Gleichstrombremsen vom Typ FD angegeben.

### Caractéristiques techniques freins FD

Le tableau (A54) suivant indique les caractéristiques techniques des freins en c.c. type FD.

Freno Brake Bremse Frein	Coppia frenante $M_b$ [Nm] Brake torque $M_b$ [Nm] Bremsmoment $M_b$ [Nm] Couple de freinage $M_b$ [Nm]			Rilascio Release Anspruchzeit Déblocage		Frenatura Braking Bremsung Freinage		Wmax per frenata Wmax per brake operation Wmax pro Bremsung Wmax par freinage			W	P
	molle / springs feder / ressorts			$t_1$	$t_{1s}$	$t_2$	$t_{2c}$	[ J ]				
	6	4	2	[ms]	[ms]	[ms]	[ms]	10 s/h	100 s/h	1000 s/h		
FD02	—	3.5	1.75	30	15	80	9	4500	1400	180	15	17
FD03	5	3.5	1.75	50	20	100	12	7000	1900	230	25	24
FD53	7.5	5	2.5	60	30	100	12					
FD04	15	10	5	80	35	140	15	10000	3100	350	30	33
FD14												
FD05	40	26	13	130	65	170	20	18000	4500	500	50	45
FD15	40	26	13	130	65	170	20					
FD55	55	37	18	—	65	170	20					
FD06S	60	40	20	—	80	220	25	20000	4800	550	70	55
FD56	—	75	37	—	90	150	20	29000	7400	800	80	65
FD06		100	50		100	20						
FD07	150	100	50	—	120	200	25	40000	9300	1000	130	65
FD08*	250	200	170	—	140	350	30	60000	14000	1500	230	100
FD09**	400	300	200	—	200	450	40	70000	15000	1700	230	120

\* valori di coppia frenante ottenuti con n° 9, 7, 6 molle rispettivamente

\* brake torque values obtained with 9, 7 and 6 springs, respectively

\* Werte, der durch den Einsatz von jeweils 9, 7, 6 Federn erreichten Bremsmomente

\* valeurs de couple de freinage obtenues respectivement avec n° 9, 7, 6 ressorts

\*\* valori di coppia frenante ottenuti con n° 12, 9, 6 molle rispettivamente

\*\* brake torque values obtained with 12, 9 and 6 springs, respectively

\*\* Werte, der durch den Einsatz von jeweils 12, 9, 6 Federn erreichten Bremsmomente

\*\* valeurs de couple de freinage obtenues respectivement avec n° 12, 9, 6 ressorts

#### Legenda:

$t_1$  = tempo di rilascio del freno con alimentatore a semionda  
 $t_{1s}$  = tempo di rilascio del freno con alimentatore a controllo elettronico dell'eccitazione  
 $t_2$  = ritardo di frenatura con interruzione lato c.a. e alimentazione separata  
 $t_{2c}$  = ritardo di frenatura con interruzione lato c.a.e c.c. - I valori di  $t_1$ ,  $t_{1s}$ ,  $t_2$ ,  $t_{2c}$  indicati nella tab. (A54) sono riferiti al freno tarato alla coppia massima, trafero medio e tensione nominale  
 $W_{max}$  = energia max per frenata  
 $W$  = energia di frenatura tra due regolazioni successive del trafero  
 $P_b$  = potenza assorbita dal freno a 20°C  
 $M_b$  = coppia frenante statica (±15%)  
 s/h = avviamenti orari

#### Key:

$t_1$  = brake release time with half-wave rectifier  
 $t_{1s}$  = brake release time with over-energizing rectifier  
 $t_2$  = brake engagement time with AC line interruption and separate power supply  
 $t_{2c}$  = brake engagement time with AC and DC line interruption - Values for  $t_1$ ,  $t_{1s}$ ,  $t_2$ ,  $t_{2c}$  indicated in the tab. (A54) are referred to brake set at maximum torque, medium air gap and rated voltage  
 $W_{max}$  = max energy per brake operation  
 $W$  = braking energy between two successive air gap adjustments  
 $P_b$  = brake power absorption at 20°C  
 $M_b$  = static braking torque (±15%)  
 s/h = starts per hour

#### Zeichenerklärung:

$t_1$  = Ansprechzeit der Bremse mit Halbwellegleichrichter  
 $t_{1s}$  = Ansprechzeit der Bremse mit elektronisch gesteuerten Erregungsgleichrichter  
 $t_2$  = Bremsverzögerung mit Unterbrechung auf Wechselstromseite und Fremdversorgung  
 $t_{2c}$  = Bremsverzögerung mit Unterbrechung auf Wechselstrom- und Gleichstromseite - Die in der Tab. (A54) angegebenen Werte  $t_1$ ,  $t_{1s}$ ,  $t_2$ ,  $t_{2c}$  beziehen sich auf eine auf das max. Bremsmoment geeichte Bremse, mit mittlerem Luftspalt und Nennspannung  
 $W_{max}$  = max. Energie pro Bremsung  
 $W$  = Bremsenergie zwischen zwei Einstellungen des Luftspalts  
 $P_b$  = bei 20°C von der Bremse aufgenommene Leistung (50 Hz)  
 $M_b$  = statisches Bremsmoment (±15%)  
 s/h = Einschaltungen pro stunde

#### Légende:

$t_1$  = temps de déblocage du frein avec dispositif d'alimentation à demi-onde  
 $t_{1s}$  = temps de déblocage du frein avec dispositif d'alimentation à contrôle électronique de l'excitation  
 $t_2$  = retard de freinage avec interruption côté c.a. et alimentation séparée  
 $t_{2c}$  = retard de freinage avec interruption côté c.a. et c.c. - Les valeurs de  $t_1$ ,  $t_{1s}$ ,  $t_2$ ,  $t_{2c}$  indiquées dans le tab. (A54) se réfèrent au frein étaloné au couple maximal, entrefer moyen et tension nominale  
 $W_{max}$  = énergie max. par freinage  
 $W$  = énergie de freinage entre deux réglages successifs de l'entrefer  
 $P_b$  = puissance absorbée par le frein à 20°C  
 $M_b$  = couple de freinage statique (±15%)  
 s/h = démarrages horaires

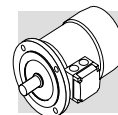

## Collegamenti freno FD

I motori standard ad una velocità sono forniti con il collegamento del raddrizzatore alla morsettiera motore già realizzato in fabbrica. Per motori a 2 velocità, e dove è richiesta l'alimentazione del freno separata, prevedere il collegamento al raddrizzatore in accordo alla tensione freno  $V_B$  indicata nella targhetta del motore. **Data la natura induttiva del carico, per il comando del freno e per l'interruzione lato corrente continua devono essere utilizzati contatti con categoria d'impiego AC-3 secondo IEC 60947-4-1.**

Tabella (A55) - Alimentazione freno dai morsetti motore ed interruzione lato a.c.

Tempo di arresto  $t_2$  ritardato e funzione delle costanti di tempo del motore. Da prevedere quando sono richiesti avviamenti/arresti progressivi.

Tabella (A56) - Bobina freno con alimentazione separata ed interruzione lato c.a.

Tempo di arresto normale ed indipendente dal motore. Si realizzano i tempi di arresto  $t_2$  indicati nella tabella (A54).

Tabella (A57) - Bobina freno con alimentazione dai morsetti motore ed interruzione lato c.a. e c.c.

Arresto rapido con i tempi d'intervento  $t_{2c}$  indicati in tabella (A54).

Tabella (A87) - Bobina freno con alimentazione separata ed interruzione lato c.a. e c.c.

Tempo di arresto ridotto secondo i valori  $t_{2c}$  indicati in tabella (A54).

## FD brake connections

On standard single-pole motors, the rectifier is connected to the motor terminal board at the factory.

For switch-pole motors and where a separate brake power supply is required, connection to rectifier must comply with brake voltage  $V_B$  stated in motor name plate.

**Because the load is of the inductive type, brake control and DC line interruption must use contacts from the usage class AC-3 to IEC 60947-4-1.**

Table (A55) - Brake power supply from motor terminals and AC line interruption

Delayed stop time  $t_2$  and function of motor time constants. Mandatory when soft-start/stops are required.

Table (A56) - Brake coil with separate power supply and AC line interruption

Normal stop time independent of motor. Achieved stop times  $t_2$  are indicated in the table (A54).

Table (A57) - Brake coil power supply from motor terminals and AC/DC line interruption.

Quick stop with operation times  $t_{2c}$  as per table (A54).

Table (A58) - Brake coil with separate power supply and AC/DC line interruption.

Stop time decreases by values  $t_{2c}$  indicated in the table (A54).

## Anschlüsse - Bremstyp FD

Die einpoligen Motoren werden vom Werk ab mit an die Motorspannung angeschlossenem Gleichrichter geliefert.

Für die polumschaltbaren Motoren, und Bremse mit separater Versorgung, wird in Übereinstimmung mit der auf dem Typenschild des Motors angegebenen Bremsspannung  $V_B$  der Anschluss an den Gleichrichter vorgesehen.

Da es sich bei der Bremsleistung um eine induktive Kraft handelt, müssen gemäß IEC 60947-4-1 für die Steuerung der Bremse und die Unterbrechung der Gleichstromseite Kontakte der Kategorie AC-3 verwendet werden.

Tabelle (A55) - Bremsversorgung über die Motorspannung und Unterbrechung der Wechselstromseite.

Verzögerter und von den Zeitkonstanten des Motors abhängige Haltezeit  $t_2$ .

Vorzusehen, wenn progressive Starts/Stops erforderlich sind.

Tabelle (A56) - Bremsspule mit separater Spannungsversorgung und Unterbrechung der Wechselstromseite. Normale und vom Motor unabhängige Stoppzeiten. Es werden die in der Tabelle (A54) angegebenen Stoppzeiten  $t_2$  realisiert.

Tabelle (A57) - Bremsspule mit Versorgung über die Motorspannung und Unterbrechung der Gleich- und der Wechselstromseite. Schneller Stopp mit den in der Tabelle (A54) angegebenen Ansprechzeiten  $t_{2c}$ .

Tabelle (A58) - Bremsspule mit separater Spannungsversorgung und Unterbrechung der Gleich- und der Wechselstromseite. Reduzierte Stoppzeiten der in der Tabelle (A54) angegebenen Werte  $t_{2c}$ .

## Raccordements frein FD

Les moteurs standard à une vitesse sont fournis avec le raccordement du redresseur au bornier moteur déjà réalisé en usine.

Pour les moteurs à 2 vitesses, et lorsqu'une alimentation séparée du frein est requise, prévoir le raccordement au redresseur conformément à la tension frein  $V_B$  indiquée sur la plaque signalétique du moteur.

**Etant donné la nature inductive de la charge, pour la commande du frein et l'interruption côté courant continu, il est nécessaire d'utiliser des contacts avec catégorie d'utilisation AC-3 selon la norme IEC 60947-4-1.**

Tableau (A55) - Alimentation frein depuis bornes moteur et interruption côté c.a.

Temps d'arrêt  $t_2$  retardé et fonction des constantes de temps du moteur.

A prévoir lorsque des démarrages/arrests progressifs sont requis.

Tableau (A56) - Bobine de frein avec alimentation séparée et interruption côté c.a.

Temps d'arrêt normal et indépendant du moteur. Les temps d'arrêts  $t_2$  sont ceux indiqués dans le tableau (A54).

Tableau (A57) - Bobine de frein avec alimentation depuis les bornes moteur et interruption côté c.a. et c.c.

Arrêt rapide avec les temps d'intervention  $t_{2c}$  indiqués dans le tableau (A54).

Tableau (A58) - Bobine de frein avec alimentation séparée et interruption côté c.a. et c.c.

Temps d'arrêt réduit selon les valeurs  $t_{2c}$  indiquées dans le tableau (A54).

(A55)

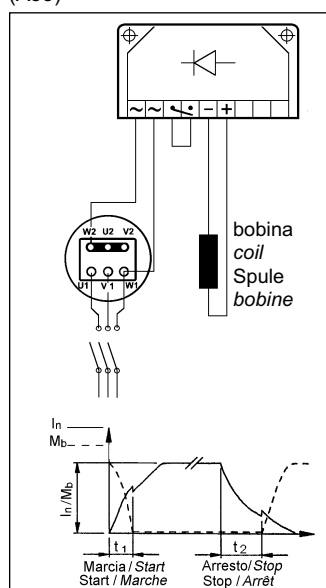

Le tableau da (A55) a (A58) riportano gli schemi tipici di collegamento per alimentazione 400 V, motori 230/400V collegati a stella e freno 230 V.

(A56)

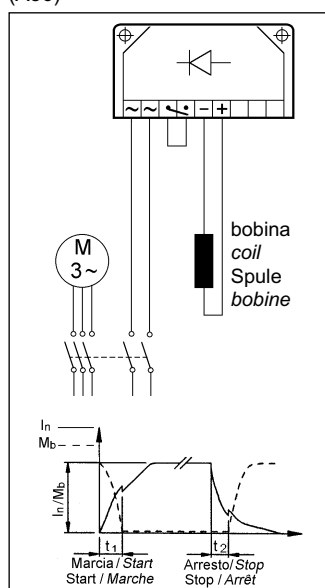

Tables (A55) through (A58) show the typical connection diagrams for 400 V power supply, star-connected 230/400V motors and 230 V brake.

(A57)

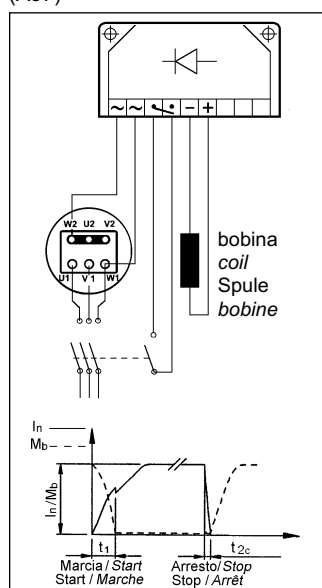

In den Tabellen (A55) bis (A58) werden die typischen Schaltungen für Versorgung mit 400 V, Motoren 230/400V mit Sternschaltung und einer Bremsspannung von 230 V wiedergegeben.

(A58)

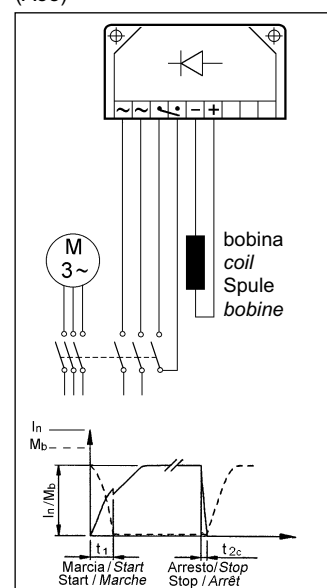

Les tableaux de (A55) à (A58) indiquent les schémas typiques de branchement pour une alimentation de 400 V, moteurs 230/400V raccordés en étoile et frein 230 V.



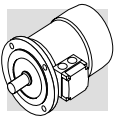

**M7 - MOTORI AUTOFRENANTI  
IN C.A., TIPO BN\_FA**

**M7 - AC BRAKE MOTORS  
TYPE BN\_FA**

**M7 - WECHSELSTROM-  
BREMSMOTOREN-TYP  
BN\_FA**

**M7 - MOTEURS FREIN EN C.A.,  
TYPE BN\_FA**

**Grandezze:** BN 63 ... BN 180M

**Frame sizes:** BN 63 ... BN 180M

**Baugrößen:** BN 63 ... BN 180M

**Tailles :** BN 63 ... BN 180M

(A59)

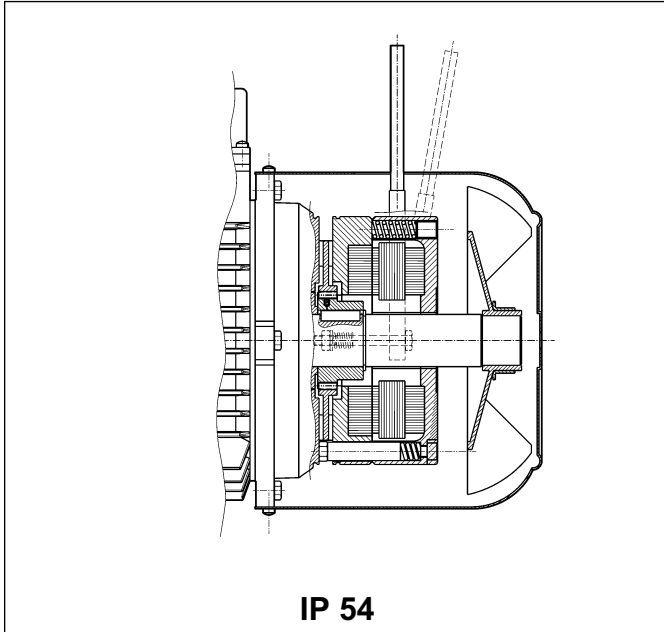

**IP 54**

(A60)

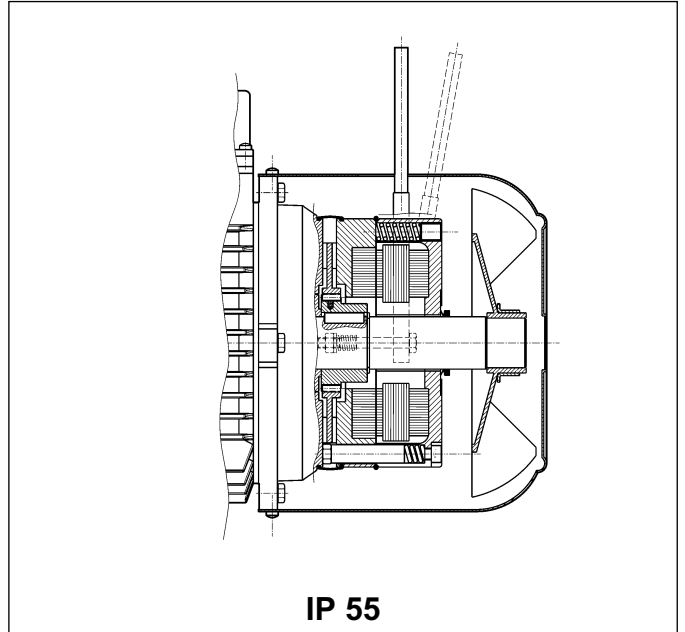

**IP 55**

Freno elettromagnetico con alimentazione in **corrente alternata** trifase, fissato con viti allo scudo motore; le molle di precarico realizzano il posizionamento assiale del corpo magnete.

Il disco freno è scorrevole assialmente sul mozzo trascinatore in acciaio calettato sull'albero e provvisto di molla antivibrazione. La coppia frenante è pre-impostata in fabbrica su valori che sono indicati nelle tabelle dati tecnici dei relativi motori.

L'azione del freno è inoltre modulabile, regolando con continuità la coppia frenante, tramite le viti che realizzano il precarico delle molle; il campo di regolazione della coppia è:  $30\% M_{bMAX} < M_b < M_{bMAX}$  ( $M_{bMAX}$  è il momento frenante max riportato in tab. (A62)).

Il freno tipo FA presenta dinamiche molto elevate che lo rendono idoneo in applicazioni dove sono richieste frequenze di avviamento elevate con tempi d'intervento molto rapidi.

A richiesta, i motori possono essere previsti di leva per lo sblocco manuale con ritorno automatico (R). Per la specifica della posizione angolare della leva vedi relativa variante alla pag. 174.

*Electromagnetic brake operates from three-phase **alternated current** power supply and is bolted onto conveyor shield. Preloading springs provide axial positioning of magnet body.*

*Steel brake disc slides axially on steel hub shrunk onto motor shaft with anti-vibration spring. Brake torque factory setting is indicated in the corresponding motor rating charts.*

*Spring preloading screws provide stepless braking torque adjustment.*

*Torque adjustment range is  $30\% M_{bMAX} < M_b < M_{bMAX}$  (where  $M_{bMAX}$  is maximum braking torque as shown in tab. (A62)).*

*Thanks to their high dynamic characteristics, FA brakes are ideal for heavy-duty applications as well as applications requiring frequent stop/starts and very fast response time.*

*Motors may be equipped with manual release lever with automatic return (R) at request. See variants at page 174 for available lever locations.*

Elektromagnetische Bremse mit **Drehstromversorgung**, die mittels Schrauben am hinteren Motorschild befestigt ist. Die Federn sorgen dabei für die axiale Ausrichtung des Magnetkörpers.

Die Brems Scheibe (Stahl) gleitet axial auf dem sich auf dem Rotor befindlichen Mitnehmer, der über eine Paßfeder mit Motorwelle verbunden und mit einer Schwingungsdämpffeder ausgestattet ist.

Das Bremsmoment wird auf das entsprechende Motormoment eingestellt (siehe Tabelle der technischen Daten der entsprechenden Motoren).

Das Bremsmoment ist stufenlos durch über die Schrauben die die Federvorspannung einstellbar. Der Einstellbereich beträgt  $30\% M_{bMAX} < M_b < M_{bMAX}$  ( $M_{bMAX}$  steht für den max. Bremsmoment, der in der Tab (A62) angegeben wird).

Die Bremse vom Typ FA zeichnet sich durch ihre hohen Dynamik aus, weshalb sie für Anwendungen geeignet sind, in denen hohe Schaltfrequenzen und schnelle Ansprechzeiten gefordert werden.

Auf Anfrage können die Motoren mit einem Lüfterhebel für die manuelle Lüftung der Bremse mit automatischer Rückstellung (R) geliefert werden. Die Angabe der Montageposition erfolgt über die Angabe der Option auf Seite 174.

*Frein électromagnétique avec alimentation en **courant alternatif** triphasé, fixé avec des vis au bouclier; les ressorts de précharge réalisent le positionnement axial de la bobine.*

*Le disque frein coulisse de façon axiale sur le moyeu d'entraînement en acier, calé sur l'arbre et doté de ressort antivibration.*

*Le couple de freinage est pré-réglé en usine aux valeurs qui sont indiquées dans les tableaux des caractéristiques techniques des moteurs correspondants.*

*De plus, l'action du frein est modulable, en réglant le couple de freinage en continu au moyen des vis qui réalisent la précharge des ressorts; la plage de réglage du couple est de  $30\% M_{bMAX} < M_b < M_{bMAX}$  ( $M_{bMAX}$  est le couple de freinage maximum indiqué dans le tab. (A62)).*

*Le frein type FA présente des caractéristiques dynamiques très élevées, il est donc adapté pour des applications nécessitant des fréquences de démarrage élevées et des temps d'intervention très rapides.*

*Sur demande, les moteurs peuvent être prévus avec levier pour le déblocage manuel avec retour automatique (R). Pour la spécification de la position angulaire du levier, voir variante page 174.*

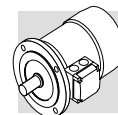

## Grado di protezione

L'esecuzione standard prevede il grado di protezione IP54. In opzione, il motore autofrenante BN\_FA viene fornito con grado di protezione **IP 55** prevedendo le seguenti varianti costruttive:

- anello V-ring posizionato sull'albero motore NDE.
- fascia di protezione in gomma
- anello O-ring

## Degree of protection

Standard protection class is IP54. Brake motor BN\_FA is also available in protection class **IP 55**, which mandates the following variants:

- V-ring at N.D.E. of motor shaft
- rubber protection sleeve
- O-ring

## Schutzart

Die Standardausführung ist Schutzart IP54 vor. Optional kann der Bremsmotor BN\_FA auch in der Schutzart **IP 55** geliefert werden, was durch die folgenden zusätzlichen Bauteile erreicht wird:

- V-Ring an der Motorwelle N.D.E.
- Schutzring aus Gummi
- O-Ring

## Degré de protection

L'exécution standard prévoit le degré de protection IP54. En option, le moteur frein BN\_FA est fourni avec degré de protection **IP 55**, les variations de construction suivantes sont prévues :

- bague V-ring positionné sur l'arbre moteur N.D.E.
- bande de protection en caoutchouc
- joint torique

## Alimentazione freno FA

Nei motori a singola polarità l'alimentazione della bobina freno è derivata direttamente dalla morsettiera motore e la tensione del freno quindi coincide con la tensione del motore. In questo caso la tensione del freno può essere omessa dalla designazione

Per i motori a doppia polarità, e per i motori con alimentazione separata del freno, è presente una morsettiera ausiliaria con 6 terminali per il collegamento alla linea del freno. In entrambi i casi il valore di tensione del freno dovrà essere specificato in designazione.

Nella tabella seguente sono riportate le condizioni di alimentazione standard del freno in c.a. per i motori a singola e doppia polarità:

## FA brake power supply

In single speed motors, power supply is brought to the brake coil direct from the motor terminal box. As a result, brake voltage and motor voltage are the same. In this case, brake voltage indication may be omitted in the designation.

Switch-pole motors and motors with separate brake power supply feature an auxiliary terminal board with 6 terminals for connection to brake line. In both cases, brake voltage indication in the designation is mandatory.

The following table reports standard AC brake power supply ratings for single- and switch-pole motors:

## Stromversorgung - Bremstyp FA

Bei den einpoligen Motoren wird die Versorgung der Bremsspule direkt vom Motorklemmenkasten abgenommen, das bedeutet, dass die Spannung der Bremse mit der Motorspannung übereinstimmt. In diesem Fall braucht die Bremsenspannung nicht extra angegeben werden.

Für die polumschaltbaren Motoren und für eine separate Bremsversorgung ist eine Hilfsklemmenleiste mit 6 Anschlüssen vorgesehen, die einen Anschluß der Bremse ermöglichen. In beiden Fällen muss die Bremsenspannung in der Bestellung angegeben werden.

In der nachstehenden Tabelle werden für die einpoligen und die polumschaltbaren Motoren die Standardspannungen der Wechselstrombremsen angegeben.

## Alimentation frein FA

Sur les moteurs à simple polarité, l'alimentation de la bobine frein dérive directement du bornier moteur, par conséquent, la tension du frein coïncide avec la tension du moteur. Dans ce cas, la tension du frein peut être omise de la désignation.

Pour les moteurs à double polarité et les moteurs avec alimentation séparée du frein, une boîte à bornes auxiliaire avec 6 bornes pour le raccordement à la ligne du frein, est présente. Dans les deux cas, la valeur de tension du frein doit être spécifiée dans la désignation.

Le tableau suivant indique les conditions d'alimentation standard du frein en c.a. pour les moteurs à simple et double polarité :

(A61)

motori a singola polarità <i>single-pole motor</i> Einpolige Motoren <i>Moteurs à simple polarité</i>	BN 63...BN 132	BN 160...BN 180
	M05...M4LB	M4LC...M5
	230Δ / 400Y V ±10% – 50 Hz	400Δ/ 690Y V ±10% – 50 Hz
	265Δ / 460Y ±10% - 60 Hz	460Y – 60 Hz

motori a doppia polarità (alimentazione da linea separata) <i>switch-pole motors (separate power supply line)</i> Polumschaltbare Motoren (separate Versorgung) <i>Moteurs à double polarité (alimentation depuis ligne séparée)</i>	BN 63...BN 132
	M05...M4
	230Δ / 400Y V ±10% – 50 Hz
	460Y - 60 Hz

Se non diversamente specificato, l'alimentazione standard del freno è 230Δ /400Y V - 50 Hz.

Su richiesta, sono disponibili tensioni speciali, nel campo 24...690 V, 50-60 Hz.

Unless otherwise specified, standard brake power supply is 230Δ /400Y V - 50 Hz.

Special voltages in the 24...690 V, 50-60 Hz range are available at request.

Falls nicht anderweitig angegeben, beträgt die Standardversorgung der Bremse 230Δ /400Y V - 50 Hz.

Auf Anfrage können Sonderspannungen von 24...690 V, 50-60 Hz geliefert werden.

Sauf spécification contraire, l'alimentation standard du frein est 230Δ /400Y V - 50 Hz.

Sur demande, des tensions spéciales sont disponibles dans la plage 24...690 V, 50-60 Hz.



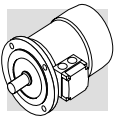

**Dati tecnici freni FA**

**Technical specifications of FA brakes**

**Technische Daten der Bremsen vom Typ FA**

**Caractéristiques techniques freins FA**

(A62)

Freno Brake Bremse Frein	Coppia frenante Brake torque Bremsmoment Couple de freinage  M <sub>b</sub> [Nm]	Rilascio Release Ansprechzeit Déblocage  t <sub>1</sub> [ms]	Frenatura Braking Bremsung Freinage  t <sub>2</sub> [ms]	W <sub>max</sub>			W [MJ]	P <sub>b</sub> [VA]
				10 s/h	100 s/h	1000 s/h		
FA 02	3.5	4	20	4500	1400	180	15	60
FA 03	7.5	4	40	7000	1900	230	25	80
FA 04	15	6	60	10000	3100	350	30	110
FA 14								
FA 05	40	8	90	18000	4500	500	50	250
FA 15								
FA 06S	60	16	120	20000	4800	550	70	470
FA 06	75	16	140	29000	7400	800	80	550
FA 07	150	16	180	40000	9300	1000	130	600
FA 08	250	20	200	60000	14000	1500	230	1200

**Legenda:**

M<sub>b</sub> = max coppia frenante statica (±15%)  
 t<sub>1</sub> = tempo di rilascio freno  
 t<sub>2</sub> = ritardo di frenatura  
 W<sub>max</sub> = energia max per frenata (capacità termica del freno)  
 W = energia di frenatura tra due regolazioni successive del traferro  
 P<sub>b</sub> = potenza assorbita dal freno a 20° (50 Hz)  
 s/h = avviamenti orari

**Key:**

M<sub>b</sub> = max static braking torque (±15%)  
 t<sub>1</sub> = brake release time  
 t<sub>2</sub> = brake engagement time  
 W<sub>max</sub> = max energy per brake operation (brake thermal capacity)  
 W = braking energy between two successive air gap adjustments  
 P<sub>b</sub> = power drawn by brake at 20° (50 Hz)  
 s/h = starts per hour

**Legende:**

M<sub>b</sub> = statisches max. Bremsmoment (±15%)  
 t<sub>1</sub> = Bremsenansprechzeit  
 t<sub>2</sub> = Bremsverzögerung  
 W<sub>max</sub> = max. Energie pro Bremsung (Wärmeleistung der Bremse)  
 W = Bremsenergie zwischen zwei Einstellungen des Luftspalts  
 P<sub>b</sub> = bei 20° von der Bremse aufgenommene Leistung (50 Hz)  
 s/h = Einschaltungen pro stunde

**Légende:**

M<sub>b</sub> = couple de freinage statique max (±15%)  
 t<sub>1</sub> = temps de déblocage frein  
 t<sub>2</sub> = retard de freinage  
 W<sub>max</sub> = énergie max par freinage (capacité thermique du frein)  
 W = énergie de freinage entre deux réglages successifs de l'entrefer  
 P<sub>b</sub> = puissance absorbée par le frein à 20° (50 Hz)  
 s/h = démarrages horaires

**N.B.**

I valori di t<sub>1</sub> e t<sub>2</sub> riportati in tabella sono riferiti al freno tarato alla coppia nominale, traferro medio e tensione nominale.

**NOTE**

Values t<sub>1</sub> and t<sub>2</sub> in the table refer to a brake set at rated torque, medium air gap and rated voltage.

**HINWEIS:**

Die in der Tabelle angegebenen Werte t<sub>1</sub> und t<sub>2</sub> beziehen sich auf eine Bremse, die auf das Nenndrehmoment, einen mittleren Luftspalt und die Standardspannung eingestellt ist.

**N.B.**

Les valeurs de t<sub>1</sub> et t<sub>2</sub> indiquées dans le tableau se réfèrent au frein étalonné au couple nominal, entrefer moyen et tension nominale.

**Collegamenti freno FA**

**FA brake connections**

**Abschlüsse - Bremstyp FA**

**Raccordements frein FA**

Per i motori con alimentazione del freno derivata direttamente dall'alimentazione motore i collegamenti alla morsettiera corrispondono a quanto riportato nello schema (A63):

The diagram (A63) shows the wiring when brake is connected directly to same power supply of the motor:

Bei den Motoren mit direkter Bremsspannungsversorgung müssen die Anschlüsse im Klemmenkasten entsprechend den Angaben im Schema (A63) angeschlossen werden:

Pour les moteurs avec alimentation du frein dérivant directement de l'alimentation moteur, les raccordements à la boîte à bornes correspondent aux indications du schéma (A63) :

(A63)

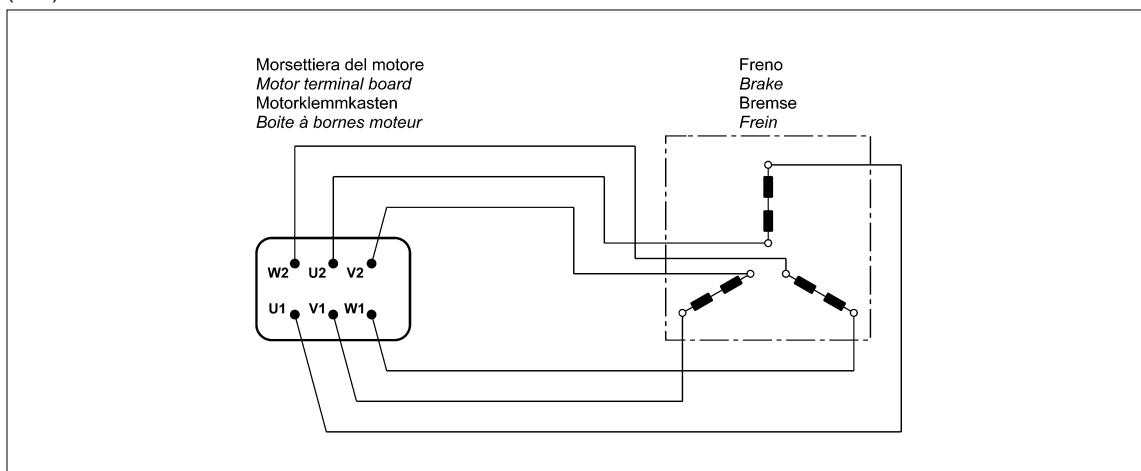

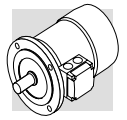

Per i motori a doppia polarità e, quando richiesto, per i motori ad una velocità con alimentazione da linea separata è prevista una morsettiera ausiliaria a 6 morsetti per il collegamento del freno; in questa esecuzione i motori prevedono la scatola copri-morsetti maggiorata. Vedi schema (A64):

*Switch-pole motors and, at request, single-pole motors with separate power supply are equipped with an auxiliary terminal board with 6 terminals for brake connection.*  
*In this version, motors feature a larger terminal box. See diagram (A64):*

Bei den polumschaltbaren Motoren und, auf Anfrage, auch bei den einpoligen Motoren mit separater Bremsversorgung ist für den Anschluss der Bremse ein Hilfsklemmenkasten mit 6 Klemmen vorgesehen. In diesen Ausführungen haben die Motoren einen größeren Klemmenkasten. Siehe Schema (A64):

*Pour les moteurs à double polarité et, lorsque cela est requis, pour les moteurs à une vitesse avec alimentation depuis ligne séparée, une boîte à bornes auxiliaire à 6 bornes est prévue pour le raccordement du frein ; dans cette exécution les moteurs prévoient un couvercle bornier majoré. Voir schéma (A64) :*

(A64)

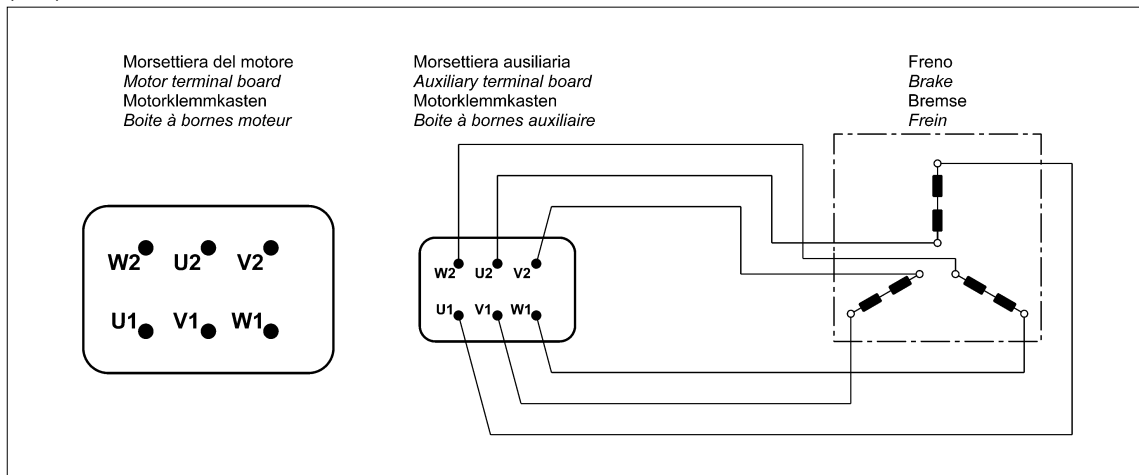

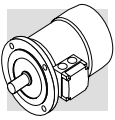

**M8 - MOTORI AUTOFRENANTI  
IN C.A., TIPO BN\_BA**

**M8 - AC BRAKE MOTORS  
TYPE BN\_BA**

**M8 - DREHSTROM-BREMS-  
MOTOREN MIT WECH-  
SELS-TROMBREMSE  
VOM TYP BN\_BA**

**M8 - MOTEURS FREIN EN C.A.,  
TYPE BN\_BA**

**Grandezze: BN 63 ... BN 132M**

**Frame sizes: BN 63 ... BN 132M**

**Baugrößen: BN 63 ... BN 132M**

**Tailles : BN 63 ... BN 132M**

(A65)

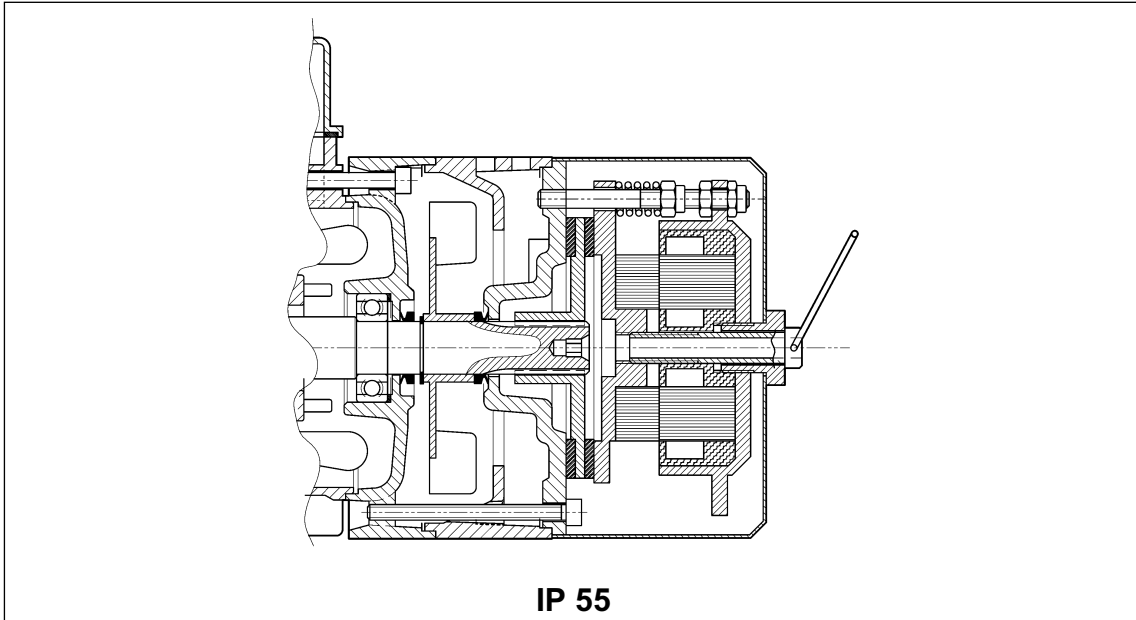

Freno elettromagnetico con alimentazione in **corrente alternata** trifase, fissato con viti allo scudo convogliatore.

Disco freno in acciaio scorrevole assialmente sull'albero motore scanalato (mozzo trascinatore in acciaio calettato sull'albero per grandezza 244).

I motori sono forniti con freno tarato alla massima coppia.

La coppia freno è regolabile con continuità agendo sulle viti di compressione delle molle; il campo di regolazione consentito è  $30\% M_{bMAX} < M_b < M_{bMAX}$  ( $M_{bMAX}$  è il momento frenante massimo riportato in tab. (A66)). Di serie i motori sono forniti completi di vite per lo sblocco manuale del freno, con mantenimento della posizione di rilascio per consentire la rotazione dell'albero motore.

La vite di sblocco deve essere smontata dopo l'utilizzo per assicurare il corretto funzionamento del freno, ed evitare situazioni potenzialmente pericolose.

Il freno BA, oltre alle elevate caratteristiche dinamiche tipiche dei freni in corrente alternata, presenta una costruzione robusta con energia di frenatura aumentata che lo rendono particolarmente idoneo a servizi pesanti, oltre che in applicazioni dove sono richieste frequenze di manovra elevate e tempi d'intervento molto rapidi.

*Electromagnetic brake operates from three-phase **alternated current** power supply and is bolted onto conveyor shield.*

*Steel brake disc slides axially on splined motor shaft (steel drive hub is shrunk onto shaft on frame size 244).*

*Factory setting is maximum brake torque.*

*Step less braking torque adjustment by screws which compress the brake springs. Allowed adjustment range is  $30\% M_{bMAX} < M_b < M_{bMAX}$  (where  $M_{bMAX}$  is maximum braking torque as shown in tab. (A66)).*

*Motors are supplied complete with manual brake release screw as standard. Screw may be locked in the release position to allow for motor shaft rotation.*

*The brake release screw must be removed after use to ensure proper brake operation and avoid potentially dangerous conditions.*

*In addition to the high dynamic characteristics typical of AC brakes, a sturdy design and increased braking energy make the BA brake ideal for heavy-duty applications as well as applications requiring frequent stop/starts and very fast response time.*

Elektromagnetische Bremse mit **Drehstromversorgung**, die mittels Schrauben am Motorschild des Motors befestigt ist.

Die Brems Scheibe (Stahl) gleitet axial auf der Rotorwelle (bei Baugröße 244 über einem auf die Welle aufgezogenem Mitnehmer aus Stahl).

Die Motoren werden mit einer auf das maximale Drehmoment des Motors eingestellten Bremse geliefert.

Das Bremsdrehmoment ist durch Betätigen der Federdruckschrauben stufenlos regelbar. Der zulässige Einstellbereich beträgt  $30\% M_{bMAX} < M_b < M_{bMAX}$  ( $M_{bMAX}$  steht für den max. Bremsmoment, das in der Tab. (A66) angegeben wird).

Die Motoren werden serienmäßig mit einer Schraube zur manuelle Bremslüftung geliefert; die arretierbar ist, um ein Drehen der Motorwelle zu ermöglichen.

Diese Schraube muss im Betrieb des Motors wieder abmontiert werden, damit die korrekte Funktion der Bremse gesichert ist.

Die Bremse vom Typ BA zeichnet sich durch ihre dynamischen Eigenschaften und die robuste Bauweise aus, durch die sie eine erhöhte Bremsenergie abzugeben kann. Diese Bremsen eignen sich besonders für einen Einsatz unter harten Bedingungen und überall dort, wo häufige Schaltfrequenzen und schnelle Ansprechzeiten gefordert werden.

*Frein électromagnétique avec alimentation en **courant alternatif** triphasé, fixé avec des vis au bouclier.*

*Disque frein en acier coulissant de façon axiale sur l'arbre moteur rainuré (moyeu d'entraînement en acier calé sur l'arbre pour la taille 244).*

*Les moteurs sont fournis avec frein étalonné au couple maximal.*

*Le couple de freinage est réglable en continu en intervenant sur les vis de compression des ressorts; la plage de réglage autorisé est de  $30\% M_{bMAX} < M_b < M_{bMAX}$  ( $M_{bMAX}$  étant le couple de freinage maximum indiqué dans le tab. (A66)).*

*De série, les moteurs sont fournis avec vis de déblocage manuel du frein, avec maintien de la position de relâchement afin de permettre la rotation de l'arbre moteur.*

*La vis de déblocage doit être démontée après utilisation afin de garantir le fonctionnement correct du frein et d'éviter les situations potentiellement dangereuses.*

*Le frein BA, outre les caractéristiques dynamiques élevées typiques des freins en courant alternatif, est de fabrication robuste avec énergie de freinage majorée, ce qui le rend particulièrement adapté pour les services difficiles ainsi que pour les applications nécessitant des fréquences de manœuvre élevées et des temps d'intervention très rapides.*

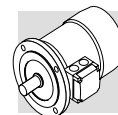

## Grado di protezione

È disponibile un'unica esecuzione, con grado di protezione IP55.

## Protection class

Only available in protection class IP55.

## Schutzart

Es ist eine nur die Ausführung in Schutzklasse IP55 verfügbar.

## Degré de protection

Il est disponible en une exécution unique, avec degré de protection IP55.

## Alimentazione freno BA

Nei motori a singola polarità l'alimentazione della bobina freno è derivata direttamente dalla morsettiera motore e la tensione del freno quindi coincide con la tensione del motore. In questo caso la tensione del freno può essere omessa dalla designazione.

Per i motori a doppia polarità, e per i motori con alimentazione separata del freno, è presente una morsettiera ausiliaria con 6 terminali per il collegamento alla linea del freno. In entrambi i casi il valore di tensione del freno dovrà essere specificato in designazione.

Nella tabella seguente sono riportate le condizioni di alimentazione standard del freno in c.a. per i motori a singola e doppia polarità:

## BA brake power supply

In single speed motors, power supply is brought to the brake coil direct from the motor terminal box. As a result, brake voltage and motor voltage are the same. In this case, brake voltage indication may be omitted in the designation.

Switch-pole motors and motors with separate brake power supply feature an auxiliary terminal board with 6 terminals for connection to brake line. In both cases, brake voltage indication in the designation is mandatory. The following table reports standard AC brake power supply ratings for single- and switch-pole motors:

## Stromversorgung - Bremstyp BA

Bei den einpoligen Motoren wird die Versorgung der Bremsspule direkt vom Motorklemmenkasten abgezweigt, das bedeutet also, dass die Spannung der Bremse mit der Motorspannung übereinstimmt. In diesem Fall braucht die Bremsenspannung nicht extra angegeben werden.

Für polumschaltbaren Motoren und für eine separate Bremsversorgung ist eine Hilfsklemmenleiste mit 6 Anschlüssen vorgesehen, die einen Anschluss der Bremse ermöglichen. In beiden Fällen muss die Bremsenspannung bei der Bestellung angegeben werden.

In der nachstehenden Tabelle werden für die einpoligen und die polumschaltbaren Motoren die Standardversorgung der Wechselstrombremsen angegeben.

## Alimentation frein BA

Sur les moteurs à simple polarité, l'alimentation de la bobine frein dérive directement du bornier moteur, par conséquent, la tension du frein coïncide avec la tension du moteur. Dans ce cas, la tension du frein peut être omise de la désignation.

Pour les moteurs à double polarité et les moteurs avec alimentation séparée du frein, un boîte à bornes auxiliaire avec 6 bornes pour le raccordement au réseau du frein, est présente. Dans les deux cas, la valeur de tension du frein doit être spécifiée dans la désignation.

Le tableau suivant indique les conditions d'alimentation standard du frein en c.a. pour les moteurs à simple et double polarité :

(A65)

<b>motori a singola polarità</b> <b>single-pole motor</b> <b>Einpolige Motoren</b> <b>Moteurs à simple polarité</b>	<b>BN 63 ... BN 132</b>
	230Δ / 400Y V ±10% – 50 Hz
	265Δ / 460Y ±10% - 60 Hz
<b>motori a doppia polarità (alimentazione da linea separata)</b> <b>switch-pole motors (separate power supply line)</b> <b>Polumschaltbare Motoren (separate Versorgung)</b> <b>Moteurs à double polarité (alimentation depuis ligne séparée)</b>	<b>BN 63 ... BN 132</b>
	230Δ / 400Y V ±10% – 50 Hz
	460Y - 60 Hz

Se non diversamente specificato, l'alimentazione standard del freno è 230Δ / 400Y V - 50 Hz.

Unless otherwise specified, standard brake power supply is 230Δ / 400Y V - 50 Hz.

Falls nicht anderweitig angegeben, beträgt die Standardversorgung der Bremse 230Δ / 400Y V - 50 Hz.

Sauf spécification contraire, l'alimentation standard du frein est 230Δ / 400Y V - 50 Hz.

Su richiesta, sono disponibili tensioni speciali, nel campo 24...690 V, 50-60 Hz.

Special voltages in the 24...690 V, 50-60 Hz range are available at request.

Auf Anfrage können Sonderspannungen von 24...690 V, 50-60 Hz geliefert werden.

Sur demande, des tensions spéciales sont disponibles dans la plage 24...690 V, 50-60 Hz.

## Dati tecnici freni BA

Nella tabella (A66) sottostante sono riportati i dati tecnici dei freni in c.a., tipo BA.

## BA brake technical specifications

The table (A66) below reports the technical specifications for AC brakes type BA.

## Technische Daten der Bremsen vom Typ BA

In der nachstehenden Tabelle (A66) werden die technischen Daten der Wechselstrombremsen vom Typ BA angegeben:

## Caractéristiques techniques freins BA

Le tableau (A66) ci-dessous indique les caractéristiques techniques des freins en c.a., type BA.

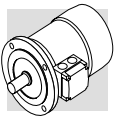

(A66)

Freno Brake Bremsse Frein	Coppia frenante Brake torque Bremsmoment Couple de freinage  $M_b$ [Nm]	Rilascio Release Ansprechzeit Déblocage  $t_1$ [ms]	Frenatura Braking Bremsung Freinage  $t_2$ [ms]	W <sub>max</sub>			W [MJ]	P <sub>b</sub> [VA]
				[ J ]				
				10 s/h	100 s/h	1000 s/h		
BA 60	5	5	20	4000	1500	180	30	60
BA 70	8	6	25	7000	2700	300	60	75
BA 80	18	6	25	10000	3100	350	80	110
BA 90	35	8	35	13000	3600	400	88	185
BA 100	50	8	35	18000	4500	500	112	225
BA 110	75	8	35	28000	6800	750	132	270
BA 140	150	15	60	60000	14000	1500	240	530

Legenda:

$M_b$  = max coppia frenante statica (±15%)

$t_1$  = tempo di rilascio freno

$t_2$  = ritardo di frenatura

$W_{max}$  = energia max per frenata (capacità termica del freno)

W = energia di frenatura tra due regolazioni successive del traferro

$P_b$  = potenza assorbita dal freno a 20° (50 Hz)

s/h = avviamenti orari

N.B.

I valori di  $t_1$  e  $t_2$  riportati in tabella sono riferiti al freno tarato alla coppia nominale, traferro medio e tensione nominale.

Key:

$M_b$  = max static braking torque (±15%)

$t_1$  = brake release time

$t_2$  = brake engagement time

$W_{max}$  = max energy per brake operation (brake thermal capacity)

W = braking energy between two successive air gap adjustments

$P_b$  = brake power absorption at 20° (50 Hz)

s/h = starts per hour

NOTE

Values  $t_1$  and  $t_2$  in the table refer to a brake set at rated torque, medium air gap and rated voltage.

Legende:

$M_b$  = statisches max. Bremsmoment (±15%)

$t_1$  = Bremsenansprechzeit

$t_2$  = Bremsverzögerung

$W_{max}$  = max. Energie pro Bremsung (Wärmeleistung der Bremse)

W = Bremsenergie zwischen zwei Einstellungen des Luftspalts

$P_b$  = bei 20° von der Bremse aufgenommene Leistung (50 Hz)

s/h = Einschaltungen pro Stunde

HINWEIS:

Die in der Tabelle angegebenen Werte  $t_1$  und  $t_2$  beziehen sich auf eine Bremse, die auf das Nenn Drehmoment, einen mittleren Luftspalt und die Standardspannung eingestellt ist.

Légende:

$M_b$  = couple de freinage statique max (±15%)

$t_1$  = temps de déblocage frein

$t_2$  = retard de freinage

$W_{max}$  = énergie max par freinage (capacité thermique du frein)

W = énergie de freinage entre deux réglages successifs de l'entrefer

$P_b$  = puissance absorbée par le frein à 20° (50 Hz)

s/h = démarrages horaires

N.B.

Les valeurs de  $t_1$  et  $t_2$  indiquées dans le tableau se réfèrent au frein étaloné au couple nominal, entrefer moyen et tension nominale.

### Collegamenti freno BA

Per i motori con alimentazione del freno derivata direttamente dall'alimentazione motore i collegamenti alla morsettiera corrispondono a quanto riportato nello schema (A67):

### BA brake connections

The diagram (A67) shows the required connections to terminal box when brake is to be connected directly to motor power supply:

### Abschlüsse - Bremstyp BA

Bei den Motoren mit direkter Bremsspannungsversorgung müssen die Anschlüsse im Klemmenkasten entsprechend den Angaben im Schema (A67) angeschlossen werden:

### Raccordements frein BA

Pour les moteurs avec alimentation du frein dérivant directement de l'alimentation moteur, les raccordements à la boîte à bornes correspondent aux indications du schéma (A67) :

(A67)

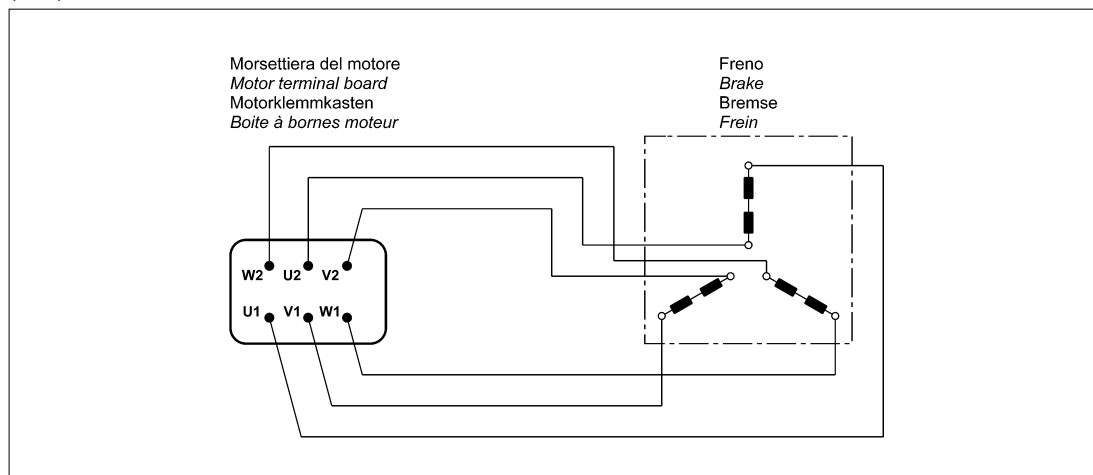

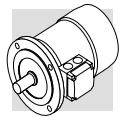

Per i motori a doppia polarità e, quando richiesto, per i motori ad una velocità con alimentazione da linea separata è prevista una morsettiera ausiliaria a 6 morsetti per il collegamento del freno; in questa esecuzione i motori prevedono la scatola coprimorsetti maggiorata. Vedi schema (A68):

*Switch-pole motors and, at request, single-pole motors with separate power supply line are equipped with an auxiliary terminal board with 6 terminals for brake connection. In this version, motors feature a larger terminal box. See diagram (A68):*

Bei den polumschaltbaren Motoren und, auf Anfrage, auch bei den einpoligen Motoren mit separater Bremsversorgung ist für den Anschluss der Bremse ein Hilfsklemmenkasten mit 6 Klemmen vorgesehen. In diesen Ausführungen haben die Motoren einen größeren Klemmenkasten. Siehe Schema (A68):

*Pour les moteurs à double polarité et, lorsque cela est requis, pour les moteurs à une vitesse avec alimentation depuis ligne séparée, une boîte à bornes auxiliaire à 6 bornes est prévue pour le raccordement du frein ; dans cette exécution les moteurs prévoient un couvercle bornier majoré. Voir schéma (A68) :*

(A68)

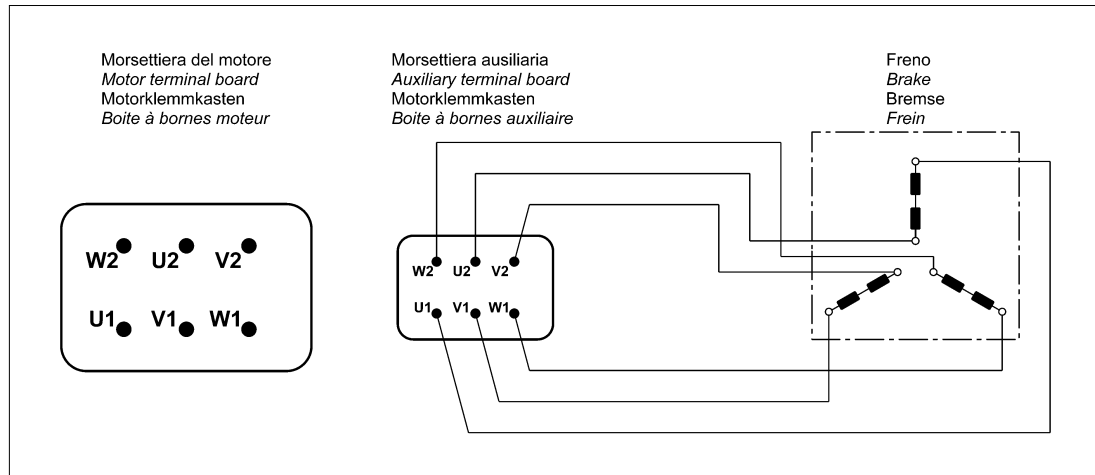

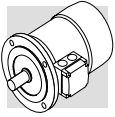

### M9 - SISTEMI DI SBLOCCO FRENO

I freni a pressione di molle tipo **FD** e **FA** possono essere dotati opzionalmente di dispositivi per lo sblocco manuale del freno, normalmente utilizzati per condurre interventi di manutenzione sulle parti di macchina, o dell'impianto, comandate dal motore.

### M9 - BRAKE RELEASE SYSTEMS

*Spring-applied brakes type **FD** and **FA** may be equipped with optional manual release devices. These are typically used for manually releasing the brake before servicing any machine or plant parts operated by the motor.*

### M9 - BREMSLÜFTHEBEL

Die Federdruckbremsen vom Typ **FD** und **FA** können Optional mit Bremslüfthebeln geliefert werden, die ein manuelles Lüften der Bremse ermöglichen. Diese Lüftungseinrichtungen können bei Instandhaltungsarbeiten an vom Motor betriebenen Maschinen- oder Anlagenteilen verwendet werden.

### M9 - SYSTEMES DE DEBLOCAGE FREIN

*Les freins à pression de ressorts type **FD** et **FA** peuvent, en option, être dotés de dispositifs de déblocage manuel du frein, normalement utilisés pour effectuer des interventions d'entretien sur les composants de la machine, ou de l'installation commandée par le moteur.*

(A69)

R

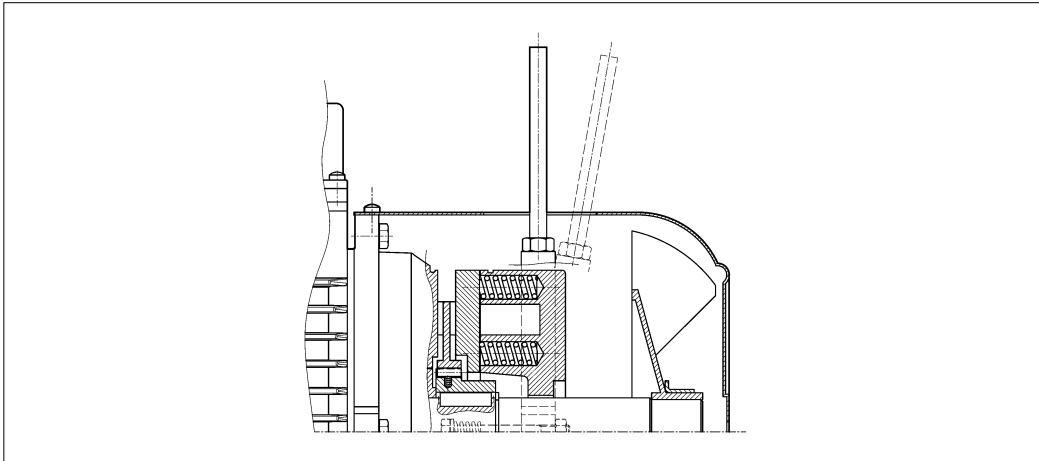

La leva di sblocco è dotata di ritorno automatico, tramite dispositivo a molla.

*A return spring brings the release lever back in the original position.*

Bremslüfthebel mit automatischer Rückstellung durch Federkraft.

*Le levier de déblocage est doté de retour automatique, au moyen d'un dispositif à ressort.*

(A70)

RM

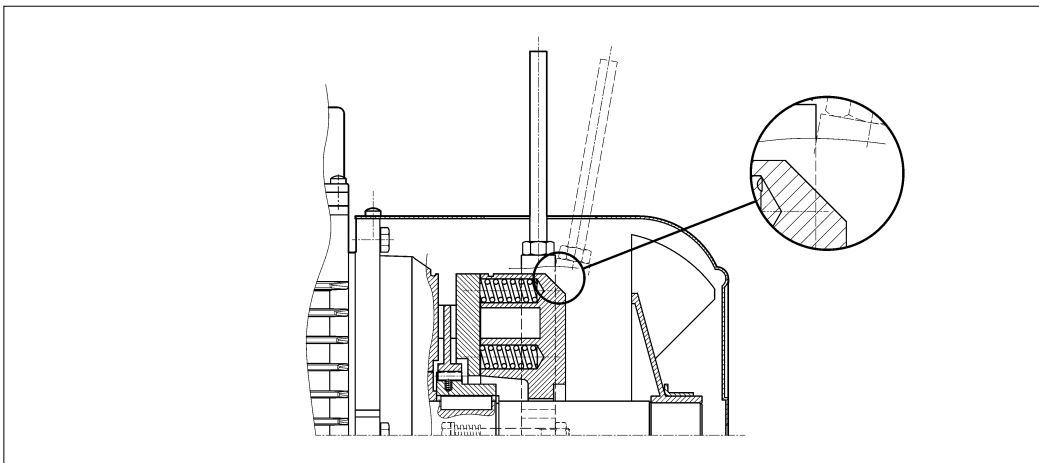

Sui motori tipo **BN\_FD** la leva di sblocco può essere temporaneamente bloccata in posizione di rilascio del freno, avvitando la stessa fino ad impegnarne l'estremità in un risalto del corpo del freno.

*On motors type **BN\_FD**, if the option **RM** is specified, the release device may be locked in the "release" position by tightening the lever until its end becomes engaged with a brake housing projection.*

Der Bremslüfthebel kann zeitweise in der Bremslüfthebel position arretiert werden, indem man ihn so lange einschraubt, bis die Bremse arretiert ist. Für die unterschiedlichen Motor-

*Levier de déblocage peut être temporairement bloqué en position de déblocage du frein en le vissant jusqu'à engager l'extrémité dans une saillie du corps du frein. La disponibilité des systèmes de*

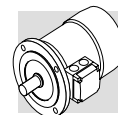

La disponibilità dei sistemi di sblocco freno è diversa per i vari tipi di motore, ed è descritta dalla tabella seguente:

The availability for the various disengagement devices is charted here below:

typen sind ebenso verschiedene Bremslüftsyste me verfügbar, die Sie der folgenden Tabelle entnehmen können:

débloccage du frein est différente en fonction des types de moteur et figure dans le tableau suivant :

(A71)	R	RM
<b>BN_FD</b>	<b>BN 63...BN 200</b>	<b>2p 63A2 ≤ H ≤ 132M2</b> <b>4p 63A4 ≤ H ≤ 132MA4</b> <b>6p 63A6 ≤ H ≤ 132MA6</b>
<b>M_FD</b>	<b>M 05...M 5</b>	<b>M 05...M 4LA</b>
<b>BN_FA</b>	<b>BN 63...BN 180M</b>	
<b>M_FA</b>	<b>M 05...M 5</b>	
<b>BN_BA</b>	<p>di serie std. supply serienmäßig de série</p>	

**Orientamento della leva di sblocco**

**Release lever orientation**

**Ausrichtung des Bremslüfthebels**

**Orientation du levier de déblocage**

Per entrambe le opzioni **R** e **RM**, la leva di sblocco del freno viene collocata, se non diversamente specificato, con orientamento di 90° in senso orario, rispetto alla posizione della morsettiera - riferimento **[AB]** nel disegno sottostante. Orientamenti alternativi, tipo **[AA]**, **[AC]** e **[AD]** possono essere richiesti citandone la relativa specifica:

Unless otherwise specified, the release lever is located 90° away from the terminal box – identified by letters **[AB]** in the diagram below – in a clockwise direction on both options **R** and **RM**. Alternative lever positions **[AA]**, **[AC]** and **[AD]** are also possible when the corresponding option is specified:

Bei beiden Optionen, **R** und **RM**, wird der Bremslüfthebel, falls nicht anderweitig festgelegt, um 90° im Uhrzeigersinn zur Position des Klemmenkastens montiert (Position **[AB]** in der nachfolgenden Zeichnung). Andere Positionen: **AA** (0° zum Klemmenkasten), **AC** (180° zum Klemmenkasten) oder **AD** (270° zum Klemmenkasten, im Uhrzeigersinn vom Lüfter aus gesehen) können unter Angabe der entsprechenden Spezifikation bestellt werden:

Pour les deux options **R** et **RM**, le levier de déblocage du frein est positionné, sauf spécification contraire, avec une orientation de 90° dans le sens des aiguilles d'une montre par rapport à la position de la boîte à bornes - référence **[AB]** sur le dessin ci-dessous. Des orientations différentes, type **[AA]**, **[AC]** et **[AD]** peuvent être demandées à condition de préciser la position correspondante :

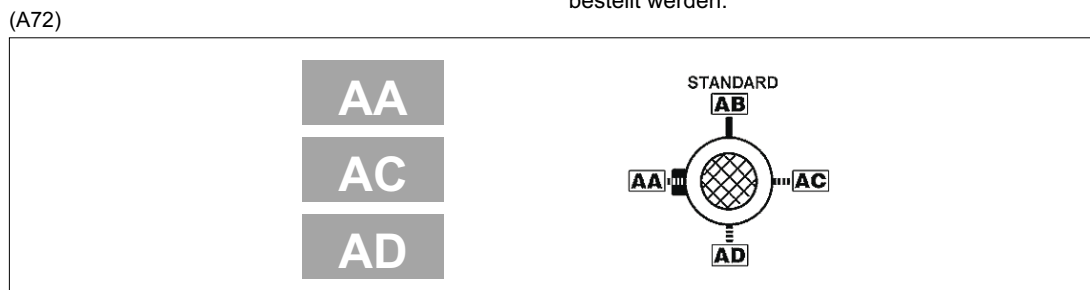

**Caratteristiche volani (F1)**

**Fly-wheel data (F1)**

**Eigenschaften der Schwunräder (F1)**

**Caractéristiques volants (F1)**

La tabella seguente riporta il peso e l'inerzia aggiuntiva dei volani che possono essere richiesti tramite l'opzione F1. Le dimensioni complessive rimangono invariate.

The table below shows values of weight and inertia of flywheel (option F1). Overall dimensions of motors remain unchanged.

Die folgende Tabelle gibt das Gewicht und das Trägheitsmoment der Zusatzschwunräder an (Option F1). Die Gesamtmaße bleiben unverändert.



Le tableau suivante indique le poids et l'inertie des volants supplémentaires sans variations de l'encombrement moteur.

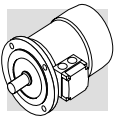



(A73)

Dati tecnici volano per motori tipo: / Main data for flywheel of motore type: / Eigenschaften der Schwungräder für Motoren typ: / Données volant pour moteurs type: BN\_FD, M\_FD

		Peso volano / Fly-wheel weight Gewicht Schwungrad / Poids volant [Kg]	Inerzia volano / Fly-wheel inertia Trägheitsmoment Schwungrad / Inertie volant [Kgm <sup>2</sup> ]
<b>BN 63</b>	<b>M05</b>	0.69	0.00063
<b>BN 71</b>	<b>M1</b>	1.13	0.00135
<b>BN 80</b>	<b>M2</b>	1.67	0.00270
<b>BN 90 S - BN 90 L</b>	–	2.51	0.00530
<b>BN 100</b>	<b>M3</b>	3.48	0.00840
<b>BN 112</b>	–	4.82	0.01483
<b>BN 132 S - BN 132 M</b>	<b>M4</b>	6.19	0.02580

**M10 - OPZIONI****M10 - OPTIONS****M10 - OPTIONEN****M10 - OPTIONS****Protezioni termiche****Thermal protective devices****Thermische Schutzeinrichtungen****Protections thermiques**

Oltre alla protezione garantita dall'interruttore magnetotermico, i motori possono essere provvisti di sonde termiche incorporate per proteggere l'avvolgimento da eccessivo riscaldamento dovuto a scarsa ventilazione o servizio intermittente.

Questa protezione dovrebbe sempre essere prevista per motori servoventilati (IC416).

In addition to the standard protection provided by the magneto-thermal device, motors can be supplied with built-in thermal probes to protect the winding against overheating caused, by insufficient ventilation or by an intermittent duty.

This additional protection should always be specified for servoventilated motors (IC416).

Abgesehen von den Motorschutzschaltern mit thermischem und elektromagnetischem Auslöser können die Motoren mit integrierten Temperaturfühlern zum Schutz der Wicklung vor Überhitzung z.B. wegen unzureichender Lüftung oder Aussetzbetriebs ausgestattet werden.

Diese Schutzeinrichtung muß bei fremdbelüfteten Motoren stets vorgesehen werden (IC416).

Outre la protection garantie par l'interrupteur magnétothermique, les moteurs peuvent être équipés de sondes thermiques incorporées pour protéger le bobinage contre une surchauffe excessive due par exemple à une ventilation insuffisante ou un service intermittent.

Cette protection devrait toujours être prévue pour les moteurs servoventilés (IC416).

**E3****Sonde termiche a termistori****Thermistors****Temperaturfühler und Thermistoren****Sondes thermométriques**

Sono dei semiconduttori che presentano una rapida variazione di resistenza in prossimità della temperatura nominale di intervento.

L'andamento della caratteristica  $R = f(T)$  è normalizzato dalle Norme DIN 44081, IEC 34-11. Questi sensori presentano il vantaggio di avere ingombri ridotti, un tempo di risposta molto contenuto e, dato che il funzionamento avviene senza contatti, sono completamente esenti da usura.

In genere vengono impiegati termistori a coefficiente di temperatura positivo denominati anche "resistori a conduttore freddo" PTC.

A differenza delle sonde termiche bimetalliche, non possono intervenire direttamente sulle correnti delle bobine di eccitazione e devono pertanto essere collegati ad una speciale unità di controllo (apparecchio di sgancio) da interfacciare alle connessioni esterne.

Con questa protezione vengono inseriti tre PTC, (collegati in serie), nell'avvolgimento con terminali disponibili in morsettiera ausiliaria.

These are semi-conductors having rapid resistance variation when they are close to the rated switch off temperature.

Variations of the  $R = f(T)$  characteristic are specified under DIN 44081, IEC 34-11 Standards.

These elements feature several advantages: compact dimensions, rapid response time and, being contact-free, absolutely no wear.

Positive temperature coefficient thermistors are normally used (also known as PTC "cold conductor resistors").

Contrary to bimetallic thermostats, they cannot directly intervene on currents of energizing coils, and must therefore be connected to a special control unit (triggering apparatus) to be interfaced with the external connections.

Thus protected, three PTCs connected in series are installed in the winding, the terminals of which are located on the auxiliary terminal-board.

Hierbei handelt es sich um Halbleiter, die eine schnelle Änderung des Widerstands in der Nähe der Nennansprechtemperatur zeigen.

Der Verlauf der Kennlinie  $R = f(T)$  ist durch die DIN-Normen 44081 und IEC 34-11 festgelegt.

Diese Sensoren haben folgende Vorteile: sie weisen geringe Außenmaße und eine äußerst kurze Ansprechzeit auf und sind vollkommen verschleißfrei, da sie berührungslos arbeiten.

Im allgemeinen werden Thermistoren mit positivem Temperaturkoeffizienten verwendet, die auch als "Kaltleiter" (PTC-Widerstände) bezeichnet werden.

Im Unterschied zu Bimetal-Temperaturfühlern können sie nicht direkt auf die Erregungsströme der Spulen wirken, sondern müssen an eine spezielle Steuereinheit (Auslösegerät) angeschlossen werden, die mit den externen Anschlüssen kompatibel ist.

Mit dieser Schutzeinrichtung werden drei in Reihe geschaltete PTC-Widerstände in die Wicklung eingesetzt, deren Endanschlüsse an einer Zusatzklemmleiste verfügbar sind.

Ce sont des semiconducteurs qui présentent une variation rapide de résistance à proximité de la température nominale d'intervention.

L'évolution de la caractéristique  $R = f(T)$  est défini par les Normes DIN 44081, IEC 34-11.

Ces capteurs présentent l'avantage d'avoir des encombrements réduits, un temps de réponse très bref et, du fait que le fonctionnement a lieu sans contact, il sont exempts d'usure.

En général, on utilise des thermistors à coefficient de température positif dénommés également "résistors à conducteur froid" PTC.

Contrairement aux sondes thermiques bimétalliques, ils ne peuvent intervenir directement sur les courants des bobines d'excitation et doivent par conséquent être reliés à une unité spéciale de contrôle (appareil de déconnexion) à interfacer aux connexions extérieures.

Avec cette protection, trois sondes, (reliées en série), sont insérées dans le bobinage avec extrémités disponibles dans le bornier auxiliaire.

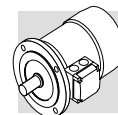

## D3

### Sonde termiche bimetalliche

I protettori di questo tipo contengono all'interno di un involucro un disco bimetallico che, raggiunta la temperatura nominale di intervento, commuta i contatti dalla posizione di riposo. Con la diminuzione della temperatura, il disco e i contatti riprendono automaticamente la posizione di riposo. Normalmente si impiegano tre sonde bimetalliche in serie con contatti normalmente chiusi e terminali disponibili in una morsettiere ausiliaria.

### Bimetallic thermostates

*These types of protective devices house a bimetal disk. When the rated switch off temperature is reached, the disk switches the contacts from their initial rest position. As temperature falls, the disk and the contacts automatically return to rest position. Three bimetallic thermostates connected in series are usually employed, with normally closed contacts. The terminals are located on an auxiliary terminal-board.*

### Bimetall-Temperaturfühler

Diese Schutzeinrichtungen bestehen aus einer Kapsel, in der sich eine Bimetallscheibe befindet, die bei Erreichen der Nennansprechtemperatur anspricht. Nach Absenkung der Temperatur geht der Schaltkontakt automatisch in Ruhestellung zurück. Normalerweise werden drei in Reihe geschaltete Bimetallfühler mit Öffnern verwendet, deren Endverschlüsse an einer Zusatzklemmleiste verfügbar sind.

### Sondes thermiqes bimétalliques

*Les protecteurs de ce type contiennent, dans une enveloppe interne, un disque bimétallique qui, lorsque la température nominale d'intervention est atteinte, commute les contacts de la position de repos. Avec la diminution de la température, le disque et les contacts reprennent automatiquement la position de repos. Normalement, on utilise trois sondes bimétalliques en série avec contacts normalement fermés et extrémités disponibles dans un bornier auxiliaire.*

## H1

### Riscaldatori anticondensa

I motori funzionanti in ambienti molto umidi e/o in presenza di forti escursioni termiche, possono essere equipaggiati con una resistenza anti-condensa. L'alimentazione monofase è prevista da morsettiere ausiliaria posta nella scatola principale. Le potenze assorbite dalla resistenza elettrica sono elencate qui di seguito:

### Anti-condensation heaters

*Where an application involves high humidity or extreme temperature fluctuation, motors may be equipped with an anti-condensate heater. A single-phase power supply is available in the auxiliary terminal board inside the main terminal box. Values for the absorbed power are listed here below:*



### Wicklungsheizung

Die Motoren, die in besonders feuchten Umgebungen und/oder unter starken Temperaturschwankungen eingesetzt werden, können mit einem Heizelement als Kondenswasserschutz ausgestattet werden. Die einphasige Versorgung erfolgt über eine Zusatzklemmleiste, die sich im Klemmenkasten befindet. Werte fuer die Leistungsaufnahme sind in folgender Tabelle aufgeführt.

### Rechauffeurs anticondensation

*Les moteurs fonctionnant dans des milieux très humides et/ou en présence de fortes plages thermiques peuvent être équipés d'une résistance anticondensation. L'alimentation monophasée est prévue par l'intermédiaire d'une boîte à bornes auxiliaire située dans la boîte principale. Les puissances absorbées sont indiqués de suite :*

(A74)

		H1
		1~ 230V ± 10% P [W]
BN 56...BN 80	M0...M2	10
BN 90...BN 160MR	M3 - M4	25
BN 160M...BN 180M	M5	50
BN 180L...BN 200L	—	65

**Importante!**  
Durante il funzionamento del motore la resistenza anticondensa non deve mai essere in-

**Warning!**  
*Always remove power supply to the anti-condensate heater before operating the motor.*

**Warnung!**  
Während des Motorbetriebs darf die Wicklungsheizung nie gespeist werden.

**Avertissement!**  
*Durant le fontionnement du moteur, la résistance anticondensation ne doit jamais être alimentée.*

## PS

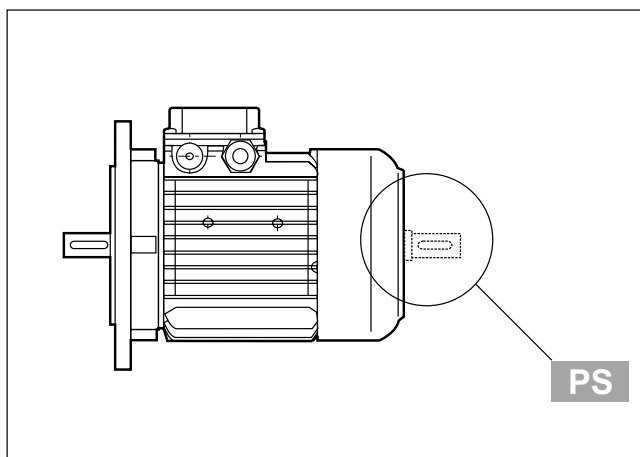

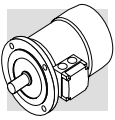

## Seconda estremità d'albero

L'opzione esclude le varianti RC, TC, U1, U2, EN1, EN2, EN3 – non applicabile ai motori con freno tipo BA. Le dimensioni sono reperibili nelle tavole dimensionali dei motori.

## Second shaft extension

*This option is not compatible with variants RC, TC, U1, U2, EN1, EN2, EN3 – and is not feasible on motors equipped with BA brake. For shaft dimensions please see motor dimensions tables.*

## Zweites Wellenende

Diese Option schließt die Optionen RC, TC, U1, U2, EN1, EN2, EN3 aus – sie kann nicht außerdem nicht an Motoren, die mit einer Bremse vom Typ BA ausgestattet sind, angebaut werden. Die entsprechenden Maße können den Maßtabellen der Motoren entnommen werden.

## Arbre à double extrémité

*L'option exclut les variantes RC, TC, U1, U2, EN1, EN2, EN3 – non applicables aux moteurs avec frein type BA. Les dimensions figurent sur les planches de dimensions des moteurs.*

AL

AR

## Dispositivo antiritorno

Nelle applicazioni dove è necessario impedire la rotazione inversa del motore dovuta all'azione del carico, è possibile impiegare motori provvisti di un dispositivo antiritorno (disponibile solo sulla serie M). Questo dispositivo, pur consentendo la libera rotazione nel senso di marcia, interviene istantaneamente in caso di mancanza di alimentazione bloccando la rotazione dell'albero nel senso inverso.

Il dispositivo antiritorno è lubrificato a vita con grasso specifico per questa applicazione.

In fase di ordine dovrà essere indicato chiaramente il senso di marcia previsto.

In nessun caso il dispositivo antiritorno dovrà essere utilizzato per impedire la rotazione inversa nel caso di collegamento elettrico errato.

Nella tabella (A75) sono indicate le coppie nominale e massima di bloccaggio attribuite ai dispositivi antiritorno utilizzati, mentre la raffigurazione schematica del dispositivo è inserita nella tabella (A76).

Le dimensioni sono le stesse del motore autofrenante.

## Backstop device

*For applications where backdriving must be avoided, motors equipped with an anti run-back device can be used (available for the M series only). While allowing rotation in the direction required, this device operates instantaneously in case of a power failure, preventing the shaft from running back.*

*The anti run-back device is life lubricated with special grease for this specific application.*

*When ordering, customers should indicate the required rotation direction, AL or AR.*

*Never use the anti run-back device to prevent reverse rotation caused by faulty electrical connection.*

*Table (A75) shows rated and maximum locking torques for the anti run-back devices.*

*A diagram of the device can be seen in Table (A76).*

*Overall dimensions are same as the corresponding brake motor.*

## Rücklaufsperr

Für Anwendungen, bei denen ein durch die Last verursachtes Rücklaufen des Motors verhindert werden soll, können Motoren installiert werden, die über eine Rücklaufsperr verfügen (nur bei Serie M verfügbar).

Diese Vorrichtung, die eine völlig unbehinderte Drehung des Motors in Laufrichtung gestattet, greift sofort ein, wenn die Spannung fehlt, und verhindert die Drehung der Welle in die Gegenrichtung.

Die Rücklaufsperr verfügt über eine Dauer - Schmierung mit einem speziell für diese Anwendung geeigneten Fett.

Bei der Bestellung muß die vorgesehene Drehrichtung des Motors genau angegeben werden.

Die Rücklaufsperr darf keinesfalls verwendet werden, um im Falle eines fehlerhaften elektrischen Anschlusses die Drehung in die Gegenrichtung zu verhindern.

In Tabelle (A75) sind die Nenndrehmomente und Höchst Drehmomente für die verwendeten Rücklaufsperr angegeben; Abbildung (A76) zeigt eine schematische Darstellung der Vorrichtung.

Die abmessungen sind ähnlich denen der Brems motoren.

## Dispositif anti-retour

*Pour les applications où il est nécessaire d'empêcher la rotation inverse du moteur à cause de l'action de la charge, il est possible d'utiliser des moteurs dotés d'un dispositif anti-retour (disponible seulement sur la série M).*

*Ce dispositif, bien que permettant la libre rotation dans le sens de marche, intervient instantanément en cas de manque d'alimentation en bloquant la rotation de l'arbre dans le sens inverse.*

*Le dispositif anti-retour est lubrifié à vie avec une graisse spécifique pour cette application.*

*En phase de commande, il faudra indiquer clairement le sens de marche prévu. En aucun cas, le dispositif anti-retour ne devra être utilisé pour empêcher la rotation inverse en cas de branchement électrique erroné.*

*Le tableau (A75) indique le couple nominal et le couple maximum de blocage attribués aux dispositifs anti-retour utilisés alors que la représentation schématique du dispositif se trouve dans le tableau (A76).*

*Le dimensions sont le même du moteur frein.*

(A75)

	Coppia nominale di bloccaggio <i>Rated locking torque</i> Nenndrehmoment der Sperre <i>Couple nominal de blocage</i>	Coppia max. di bloccaggio <i>Max. locking torque</i> Max. Drehmoment der Sperre <i>Couple maxi. de blocage</i>	Velocità di distacco <i>Release speed</i> Ausrückgeschwindigkeit <i>Vitesse de décolllement</i>
	[Nm]	[Nm]	[min <sup>-1</sup> ]
<b>M1</b>	6	10	750
<b>M2</b>	16	27	650
<b>M3</b>	54	92	520
<b>M4</b>	110	205	430

(A76)

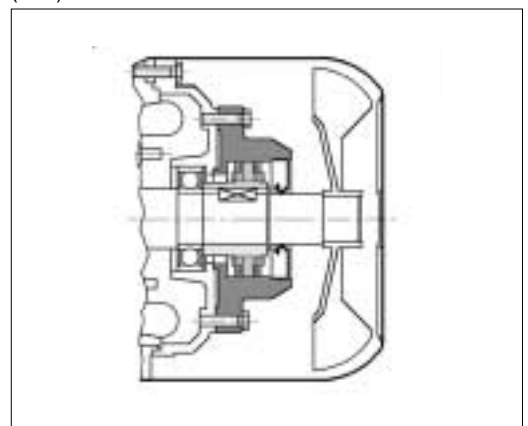

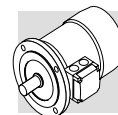

## Ventilazione

I motori sono raffreddati mediante ventilazione esterna (IC 411 secondo CEI EN 60034-6) e sono provvisti di ventola radiale in plastica, funzionante in entrambi i versi di rotazione.

L'installazione dovrà assicurare una distanza minima della calotta copriventola dalla parete più vicina, in modo da non creare impedimento alla circolazione dell'aria, oltre che permettere l'esecuzione della manutenzione ordinaria del motore e, se presente, del freno.

Su richiesta, a partire dalle grandezze BN 71, oppure M1, i motori possono essere forniti con ventilazione forzata ad alimentazione indipendente. Il raffreddamento è realizzato per mezzo di un ventilatore assiale con alimentazione indipendente, montato sulla calotta copriventola (metodo di raffreddamento IC 416).

Questa esecuzione è utilizzata in caso di alimentazione del motore tramite inverter allo scopo di estendere il campo di funzionamento a coppia costante anche a bassa velocità, o quando per lo stesso sono richieste elevate frequenze di avviamento.

Da questa opzione sono esclusi i motori autofrenanti tipo BN\_BA e tutti i motori con doppia sporgenza d'albero (opzione PS).

## Ventilation

Motors are cooled through outer air blow (IC 411 according to CEI EN 60034-6) and are equipped with a plastic radial fan, which operates in both directions.

Ensure that fan cover is installed at a suitable distance from the closest wall so to allow air circulation and servicing of motor and brake, if fitted.

On request, motors can be supplied with independently power-supplied forced ventilation system starting from BN 71 or M1 size.

Motor is cooled by an axial fan with independent power supply and fitted on the fan cover (IC 416 cooling system).

This version is used in case of motor driven by inverter so that steady torque operation is possible even at low speed or when high starting frequencies are needed.

Brake motors of BN\_BA type and all motors with rear shaft projection (PS option) are excluded.

## Belüftung

Die Motoren werden mittels Fremdbelüftung gekühlt (IC 411 gemäß CEI EN 60034-6) und sind mit einem Radiallüfterrad aus Kunststoff ausgestattet, das in beide Richtungen dreht.

Die Installation muss zwischen Lüfterradkappe und der nächstliegenden Wand einen Mindestabstand berücksichtigen, so dass der Luftumlauf nicht behindert werden kann. Dieser Abstand ist jedoch ebenso für die regelmäßige Instandhaltung des Motors und, falls vorhanden, der Bremse erforderlich.

Ab der Baugröße BN 71 oder M1 können die Motoren auf Anfrage mit einer unabhängig gespeisten Zwangsbelüftung geliefert werden. Die Kühlung erfolgt hierdurch einen unabhängig gespeisten Axialventilator, der auf die Lüfterradkappe (Kühlmethode IC 416) montiert wird.

Diese Ausführung wird im Fall eines über einen Frequenzumrichter versorgten Motor verwendet, so dass der Betriebsbereich bei konstantem Drehmoment auch auf die niedrige Drehzahl ausgedehnt wird, oder im Fall von hohen Anlauffrequenzen.

Von dieser Option ausgeschlossen sind die Bremsmotoren BN\_BA und Motoren mit beidseitig herausragender Welle (Option PS).

## Ventilation

Les moteurs sont refroidis par ventilation externe (IC 411 selon CEI EN 60034-6) et sont équipés de ventilateur radial en plastique fonctionnant dans les deux sens de rotation.



L'installation doit garantir une distance minimum de la calotte cache-ventilateur par rapport au mur le plus proche de façon à ne pas créer d'empêchement à la circulation de l'air ainsi que pour permettre les interventions d'entretien ordinaire du moteur et, si présent, du frein.

Sur demande, à partir de la taille BN 71, ou M1, les moteurs peuvent être fournis avec ventilation forcée à alimentation indépendante. Le refroidissement est réalisé au moyen d'un ventilateur axial avec alimentation indépendante monté sur la calotte cache-ventilateur (méthode de refroidissement IC 416).

Cette exécution est utilisée en cas d'alimentation du moteur par variateur dans le but d'étendre aussi la plage de fonctionnement à couple constant aux faibles vitesses ou lorsque des fréquences de démarrage élevées sont nécessaire à celui-ci.

Les moteurs frein type BN\_BA et les moteurs avec arbre sortant des deux côtés (option PS) SP sont exclus de cette option.

(A77)

Dati di alimentazione / Power supply / Daten der Stromversorgung / Données d'alimentation					
		V a.c. ± 10%	Hz	P [W]	I [A]
BN 71	M1	1~ 230	50 / 60	22	0.14
BN 80	M2			22	0.14
BN 90	—			40	0.25
BN 100 (*)	M3			50	0.25
BN 112	—	3~ 230 Δ / 400Y	50	50	0.26 / 0.15
BN 132S	M4S			110	0.38 / 0.22
BN 132M...BN 160MR	M4L				
BN 160...BN 180M	M5		50	180	1.25 / 0.72

Per la variante sono disponibili due esecuzioni alternative, denominate **U1** e **U2**, aventi lo stesso ingombro in senso longitudinale. Per entrambe le esecuzioni, la maggiore lunghezza della calotta copriventola ( $\Delta L$ ) è riportata nella tabella che segue. Dimensioni complessive ricavabili dalle tavole dimensionali dei motori.



This variant has two different models, called **U1** and **U2**, having the same longitudinal size. Longer side of fan cover ( $\Delta L$ ) is specified for both models in the table below. Overall dimension can be reckoned from motor size table.

Für die Varianten sind als Alternative zwei Ausführungen verfügbar: **U1** und **U2** mit dem gleichen Längsmaßen. Für beide Ausführungen wird die Verlängerung der Lüfterradkappe ( $\Delta L$ ) in der nachstehenden Tabelle wiedergegeben. Gesamtmaße können den Tabellen entnommen werden, in denen die Motormaße angegeben werden.

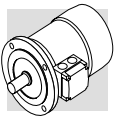
Pour la variante sont disponibles deux exécutions alternatives, dénommées **U1** et **U2**, ayant le même encombrement dans le sens longitudinal. Pour les deux exécutions, la majoration de la longueur de la calotte cache-ventilateur ( $\Delta L$ ) est indiquée dans le tableau suivant. Dimensions totales à calculer d'après les planches de dimensions des moteurs.



(A78)

Tabella maggiorazione lunghezze motore / Extra length for servoveilated motors Tabelle - Motorverlängerung / Tableau majoration longueurs moteur			
		$\Delta L_1$	$\Delta L_2$
<b>BN 71</b>	<b>M1</b>	93	32
<b>BN 80</b>	<b>M2</b>	127	55
<b>BN 90</b>	—	131	48
<b>BN 100</b>	<b>M3</b>	119	28
<b>BN 112</b>	—	130	31
<b>BN 132S</b>	<b>M4S</b>	161	51
<b>BN 132M</b>	<b>M4L</b>	161	51

$\Delta L_1$  = variazione dimensionale rispetto alla quota LB del motore standard corrispondente

$\Delta L_1$  = extra length to LB value of corresponding standard motor

$\Delta L_1$  = Maßänderung gegenüber Maß LB des entsprechenden Standardmotors

$\Delta L_1$  = variation de dimension par rapport à la cote LB du moteur standard correspondant

$\Delta L_2$  = variazione dimensionale rispetto alla quota LB del motore autofrenante corrispondente

$\Delta L_2$  = extra length to LB value of corresponding brake motor

$\Delta L_2$  = Maßänderung gegenüber Maß LB des entsprechenden Bremsmotors

$\Delta L_2$  = variation de dimension par rapport à la cote LB du moteur frein correspondant

**U1**



Terminali di alimentazione del ventilatore in scatola morsetti separata.

Nei motori autofrenanti grandezza BN 71...BN 160MR, con variante **U1**, la leva di sblocco non è collocabile nella posizione AA. L'opzione non è disponibile per i motori conformi alle norme CSA e UL (opzione CUS).

*Fan wiring terminals are housed in a separate terminal box.*

*In brake motors of size BN 71...BN 160MR, with **U1** model, the release lever cannot be positioned to AA.*

*The option is not applicable to motors compliant with the CSA and UL norms (option CUS).*

Versorgungsanschlüsse des Ventilators im Zusatzklemmenkasten.

Bei den Bremsmotoren in der Baugröße BN 71...BN 160MR, mit Variante **U1** kann der Bremslösehebel nicht in der Position AA. Die Option ist nicht anwendbar für die Motoren entsprechend den Normen CSA und UL (Option CUS).

*Bornes d'alimentation du ventilateur dans un bornier séparé.*

*Pour les moteurs frein taille BN 71...BN 160MR, avec variante **U1**, le levier de déblocage ne peut être installé en position AA. L'option n'est pas disponible pour les moteurs conformes aux normes CSA et UL (option CUS).*

**U2**



I terminali del ventilatore sono collocati nella scatola morsetti-riera principale del motore.

L'opzione U2 non è applicabile ai motori da BN 160 a BN 200L, con eccezione dei motori BN 160MR, per i quali l'opzione è disponibile e ai motori con opzione CUS (conformi alle norme CSA e UL).

*Fan terminals are wired in the motor terminal box.*

*The U2 option does not apply to motors BN 160 through BN 200L, with the only exception of motor BN 160MR for which the option is available instead and to motors with option CUS (compliant to norms CSA and UL).*



Versorgungsanschlüsse des Ventilators befinden sich im Hauptklemmenkasten des Motors.

Die Option U2 ist nicht anwendbar bei den Motoren BN160M...BN200L, außer den Motoren BN160MR wofür die Option verfügbar ist, und bei den Motoren mit der CUS-Option (entsprechend den Normen CSA und UL).

*Bornes d'alimentation du ventilateur dans le bornier principal du moteur.*

*L'option n'est pas applicable aux moteurs BN 160...BN 200L, sauf pour les moteurs BN 160MR, pour lesquels l'option est disponible et aux moteurs avec l'option CUS (conforme aux normes CSA et UL).*

(A79)

(*)			V a.c. $\pm$ 10%	Hz	P [W]	I [A]
	<b>BN 100_U2</b>	<b>M3</b>	3~ 230 $\Delta$ / 400Y	50 / 60	40	0.24 / 0.14

**RC**

**Tettuccio parapigioggia**

Il dispositivo parapigioggia, che è raccomandato quando il motore è montato verticalmente con l'albero verso il basso, serve a proteggere il motore stesso dall'ingresso di corpi solidi e dallo stillicidio.

**Drip cover**

*The drip cover protects the motor from dripping and avoids the ingress of solid bodies. It is recommended when motor is installed in a vertical position with the shaft downwards.*

**Schutzdach**

Das Schutzdach, dessen Montage dann empfohlen wird, wenn der Motor senkrecht mit einer nach unten gerichteten Welle ausgerichtet wird, dient dem Schutz des Motors vor einem Eindringen von festen Fremdkörpern und Tropfwasser.

**Capot de protection anti-pluie**

*Le capot de protection anti-pluie est recommandé lorsque le moteur est monté verticalement avec l'arbre vers le bas, il sert à protéger le moteur contre l'introduction de corps solides et le suintement.*

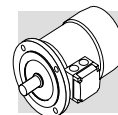



Le dimensioni aggiuntive sono indicate nella tabella (A80). Il tettuccio esclude le varianti PS, EN1, EN2, EN3 e non è applicabile ai motori con freno tipo BA

*Relevant dimensions are indicated in the table (A80). The drip cover is not compatible with variants PS, EN1, EN2, EN3 and will not fit motors equipped with a BA brake.*

Die Maßerweiterungen werden in der Tabelle (A80) angegeben. Das Schutzdach schließt die Möglichkeit der Varianten PS, EN1, EN2, EN3 und kann bei Motoren mit dem Bremstyp BA nicht montiert werden.

*Les dimensions à ajouter sont indiquées dans le tableau (A80). Le capot antipluie exclue les variantes PS, EN1, EN2, EN3 et n'est pas applicable aux moteurs avec frein type BA.*

(A80)

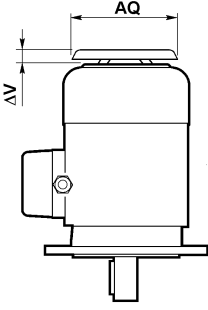
		AQ	$\Delta V$	
<b>BN 63</b>	<b>M05</b>	118	24	
<b>BN 71</b>	<b>M1</b>	134	27	
<b>BN 80</b>	<b>M2</b>	134	25	
<b>BN 90</b>	—	168	30	
<b>BN 100</b>	<b>M3</b>	168	28	
<b>BN 112</b>	—	211	32	
<b>BN 132...BN 160MR</b>	<b>M4</b>	211	32	
<b>BN 160M...BN 180M</b>	<b>M5</b>	270	36	
<b>BN 180L...BN 200L</b>	—	310	36	

## TC

### Tettuccio tessile

La variante del tettuccio tipo TC è da specificare quando il motore è installato in ambienti dell'industria tessile, dove sono presenti filamenti che potrebbero ostruire la griglia del copriventola, impedendo il regolare flusso dell'aria di raffreddamento. L'opzione esclude le varianti EN1, EN2, EN3 e non è applicabile ai motori con freno tipo BA. L'ingombro complessivo è lo stesso del tettuccio tipo RC.

### Textile canopy

Option TC is a cover variant for textile industry environments, where lint may obstruct the fan grid and prevent a regular flow of cooling air. This option is not compatible with variants EN1, EN2, EN3 and will not fit motors equipped with a BA brake. Overall dimensions are the same as drip cover type RC.

### Schutzdach

Die Variante des Schutzdachs vom Typ TC muss dann spezifiziert werden, wenn der Motor in Bereichen der Textilindustrie installiert wird, in denen Stofffusseln das Lüfterradgitter verstopfen und so einen regulären Kühlluftfluss verhindern könnten. Diese Option schließt die Möglichkeit der Varianten EN1, EN2, EN3 aus und kann bei Motoren mit einer Bremse vom Typ BA nicht appliziert werden. Die Gesamtmaße entsprechen denen des Schutzdachs vom Typ RC.

### Capot textile

*La variante del capot type TC est à spécifier lorsque le moteur est installé dans des sites de l'industrie textile, où sont présents des filaments qui pourraient obstruer la grille du cache-ventilateur et empêcher le flux régulier de l'air de refroidissement. L'option exclue les variantes EN1, EN2, EN3 et n'est pas applicable aux moteurs avec frein type BA. L'encombrement total est identique à celui du capot type RC.*

### Dispositivi di retroazione

I motori possono essere dotati di tre diversi tipi di encoder, qui di seguito descritti. Il montaggio dell'encoder esclude le esecuzioni con doppia estremità d'albero (PS) e tettuccio di protezione (RC, TC). Il dispositivo non è applicabile ai motori dotati del freno in c.a., tipo BA.

### Feedback units

*Motors may be combined with three different types of encoders to achieve feedback circuits. Configurations with double-extended shaft (PS) and rain canopy (RC, TC) are not compatible with encoder installation. Also not compatible are motors equipped with a.c. brakes, type BA.*

### Geber-anschluß

Die Motoren können mit drei unterschiedlichen Encodertypen ausgestattet werden. Nachstehend finden Sie die entsprechenden Beschreibungen. Die Montage des Encoders schließt die Version mit zweitem Wellenende (PS) und Schutzdach (RC, TC) aus. Die Vorrichtung kann an Motoren mit Bremse vom Typ BA nicht angebaut werden.

### Dispositifs de retroaction

*Pour moteurs peuvent être dotés de trois types de codeurs différents, décrits ci-après. Le montage du codeur exclu les exécutions avec arbre à double extrémité (PS) et le capot de protection (RC, TC). Le dispositif n'est pas applicable aux moteurs avec frein en c.a., type BA.*

## EN1

Encoder incrementale,  $V_{IN}=5V$ , uscita line-driver RS 422.

*Incremental encoder,  $V_{IN}=5V$ , line-driver output RS 422.*

Inkremental-Encoder,  $V_{IN}=5V$ , Ausgang „line-driver“ RS 422.

*Codeur incrémental,  $V_{IN}=5V$ , sortie line-driver RS 422.*

## EN2

Encoder incrementale,  $V_{IN}=10-30V$ , uscita line driver RS 422.

*Incremental encoder,  $V_{IN}=10-30V$ , line-driver output RS 422.*

Inkremental-Encoder,  $V_{IN}=10-30V$ , Ausgang „line driver“ RS 422.

*Codeur incrémental,  $V_{IN}=10-30V$ , sortie line-driver RS 422.*

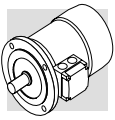

# EN3

Encoder incrementale,  $V_{IN}=12-30$  V, uscita push-pull 12-30 V

Incremental encoder,  $V_{IN}=12-30$  V, push-pull output 12-30 V

Inkremental-Encoder,  $V_{IN}=12-30$  V, Ausgang „push-pull“ 12-30 V

Codeur incrémental,  $V_{IN}=12-30$  V, sortie push-pull 12-30 V

(A81)

	EN1	EN2	EN3
interfaccia / Interface Schnittstelle / interface	RS 422	RS 422	push-pull
tensione alimentazione / Power supply voltage Versorgungsspannung / tension d'alimentation	[V] 4...6	10...30	12...30
tensione di uscita / Output voltage Ausgangsspannung / tension de sortie	[V] 5	5	12...30
corrente di esercizio senza carico / No-load operating current Betriebsstrom ohne Belastung / courant d'utilisation sans charge	[mA] 120	100	100
n° di impulsi per giro / No. of pulses per revolution Impulse pro Drehung / nbre d'impulsions par tour	1024		
n° segnali / No. of signals Signale / nbre de signaux	6 (A, B, C + segnali invertiti / inverted signals invertierte Signale / signaux inversés)		
max. frequenza di uscita / Max. output frequency Max. Ausgangsfrequenz / fréquence max. de sortie	[kHz] 300	300	200
max. velocità / Max. speed Max. Drehzahl / vitesse max.	[min <sup>-1</sup> ]	6000 (9000 min <sup>-1</sup> ) x 10s	
campo di temperatura / Temperature range Temperaturbereich / plage de température	[°C]	-20...+70	
grado di protezione / Protection class Schutzgrad / degré de protection	IP 65		

EN1, EN2, EN3	
BN 63...BN 200L	M05...M5
BN 63_FD...BN 200L_FD	M05_FD...M5_FD
BN 63_FA...BN 200L_FA	M05_FA...M5_FA

EN_ + U1		
		L3
BN 160M...BN 180M	M5	72
BN 180L...BN 200L	-	82
BN 160M_FD...BN 180M_FD	M5_FD	35
BN 180L_FD...BN 200L_FD	-	41

Se l'opzione EN\_ è richiesta per motori di grandezza BN71...BN160MR e M1...M4, contemporaneamente all'opzione U1/U2, le variazioni dimensionali coincidono con quelle dell'opzione U1/U2.

If the encoder device (options EN1, EN2, EN3) is specified on motors BN71...BN160MR and M1...M4, along with the independent fan cooling (options U1, U2), the extra length of motor is coincident with that of the correspondent U1 and U2 execution.

Wenn der Encoder (Optionen EN1, EN2, EN3) für Motoren der Baugrößen BN71...BN160MR und M1...M4 zusammen mit Fremd Lüftung (Optionen U1, U2) ausgelegt ist, stimmen die Maßänderungen des Motors mit jenen der entsprechenden Ausführungen U1 und U2 überein.





Si un codeur (option EN1, EN2, EN3) est nécessaire sur les moteurs de tailles BN71...BN160MR et M1...M4, en association avec la ventilation forcée (options U1, U2), la variation de dimensions du moteur coïncide avec celle des exécutions U1 et U2 correspondantes.

2 P

3000 min<sup>-1</sup> - S1

50 Hz



Pn kW		n min <sup>-1</sup>	Mn Nm	η (100%) %	η (75%) %	cos φ	In [400V] A	Is In	Ms Mn	Ma Mn	Jm x 10 <sup>-4</sup> kgm <sup>2</sup>	IM B5  Kg	freno c.c. / d.c. brake G.S.-bremse / frein c.c.					freno c.a. / a.c. brake W.S.-bremse / frein c.a.											
													FD					FA				BA							
													Mod.	Mb Nm	Z <sub>o</sub> 1/h NB SB	Jm x 10 <sup>-4</sup> Kgm <sup>2</sup>	IM B5  Kg	Mod.	Mb Nm	Z <sub>o</sub> 1/h	Jm x 10 <sup>-4</sup> kgm <sup>2</sup>	IM B5  Kg	Mod.	Mb max Nm	Z <sub>o</sub> 1/h	Jm x 10 <sup>-4</sup> kgm <sup>2</sup>	IM B5  Kg		
0.18	<b>BN 63A</b>	2	2730	0.63	59.9	56.9	0.77	0.56	3.0	2.1	2	2.0	3.5	<b>FD 02</b>	1.75	3900	4800	2.6	5.2	<b>FA 02</b>	1.75	4800	2.6	5.0	<b>BA 60</b>	5	3500	4.0	5.8
0.25	<b>BN 63B</b>	2	2740	0.87	66.0	64.8	0.76	0.72	3.3	2.3	2.3	3.9	3.9	<b>FD 02</b>	1.75	3900	4800	3.0	5.6	<b>FA 02</b>	1.75	4800	3.0	5.4	<b>BA 60</b>	5	3600	4.3	6.2
0.37	<b>BN 63C</b>	2	2800	1.26	69.1	66.8	0.78	0.99	3.9	2.6	2.6	3.3	5.1	<b>FD 02</b>	3.5	3600	4500	3.9	6.8	<b>FA 02</b>	3.5	4500	3.9	6.6	<b>BA 60</b>	5	3500	5.3	7.4
0.37	<b>BN 71A</b>	2	2820	1.25	73.8	73.0	0.76	0.95	4.8	2.8	2.6	3.5	5.4	<b>FD 03</b>	3.5	3000	4100	4.6	8.1	<b>FA 03</b>	3.5	4200	4.6	7.8	<b>BA 70</b>	8	3500	5.5	9.3
0.55	<b>BN 71B</b>	2	2820	1.86	76.0	75.8	0.76	1.37	5.0	2.9	2.8	4.1	6.2	<b>FD 03</b>	5	2900	4200	5.3	8.9	<b>FA 03</b>	5	4200	5.3	8.6	<b>BA 70</b>	8	3600	6.1	10.1
0.75	<b>BN 71C</b>	2	2810	2.6	76.6	76.2	0.76	1.86	5.1	3.1	2.8	5.0	7.3	<b>FD 03</b>	5	1900	3300	6.1	10	<b>FA 03</b>	5	3600	6.1	9.7	<b>BA 70</b>	8	3200	7.0	11.2
0.75	<b>BN 80A</b>	2	2810	2.6	76.2	75.5	0.81	1.75	4.8	2.6	2.2	7.8	8.6	<b>FD 04</b>	5	1700	3200	9.4	12.5	<b>FA 04</b>	5	3200	9.4	12.4	<b>BA 80</b>	18	2800	10.8	13.9
1.1	<b>BN 80B</b>	2	2800	3.8	76.4	76.2	0.81	2.57	4.8	2.8	2.4	9.0	9.5	<b>FD 04</b>	10	1500	3000	10.6	13.4	<b>FA 04</b>	10	3000	10.6	13.3	<b>BA 80</b>	18	2700	12.0	14.8
1.5	<b>BN 80C</b>	2	2800	5.1	79.1	79.5	0.81	3.4	4.9	2.7	2.4	11.4	11.3	<b>FD 04</b>	15	1300	2600	13.0	15.2	<b>FA 04</b>	15	2600	13.0	15.1	<b>BA 80</b>	18	2400	14.4	16.6
1.5	<b>BN 90SA</b>	2	2870	5.0	82.0	81.5	0.80	3.3	5.9	2.7	2.6	12.5	12.3	<b>FD 14</b>	15	900	2200	14.1	16.5	<b>FA 14</b>	15	2200	14.1	16.4	<b>BA 90</b>	35	1600	19.5	19.6
1.85	<b>BN 90SB</b>	2	2880	6.1	82.5	82.0	0.80	4.0	6.2	2.9	2.6	16.7	14	<b>FD 14</b>	15	900	2200	18.3	18.2	<b>FA 14</b>	15	2200	18.3	18.1	<b>BA 90</b>	35	1700	23.7	21.3
2.2	<b>BN 90L</b>	2	2880	7.3	82.7	82.1	0.80	4.8	6.3	2.9	2.7	16.7	14	<b>FD 05</b>	26	900	2200	21	20	<b>FA 05</b>	26	2200	21	20.7	<b>BA 90</b>	35	1700	24	21.3
3	<b>BN 100L</b>	2	2860	10.0	82.8	82.6	0.79	6.6	5.7	2.6	2.2	31	20	<b>FD 15</b>	26	700	1600	35	26	<b>FA 15</b>	26	1600	35	27	<b>BA 100</b>	50	1300	43	30
4	<b>BN 100LB</b>	2	2870	13.3	84.3	84.4	0.80	8.6	5.9	2.7	2.5	39	23	<b>FD 15</b>	40	450	900	43	29	<b>FA 15</b>	40	1000	43	30	<b>BA 100</b>	50	850	51	33
4	<b>BN 112M</b>	2	2900	13.2	85.5	84.5	0.82	8.2	6.9	3	2.9	57	28	<b>FD 06S</b>	40	—	950	66	39	<b>FA 06S</b>	40	950	66	40	<b>BA 110</b>	75	850	73	41
5.5	<b>BN 132SA</b>	2	2890	18.2	86.1	85.7	0.84	11.0	6	2.6	2.2	101	35	<b>FD 06</b>	50	—	600	112	48	<b>FA 06</b>	50	600	112	49	<b>BA 140</b>	150	500	151	67
7.5	<b>BN 132SB</b>	2	2900	25	87.2	87.1	0.85	14.6	6.4	2.6	2.2	145	42	<b>FD 06</b>	50	—	550	154	55	<b>FA 06</b>	50	550	154	56	<b>BA 140</b>	150	450	195	74
9.2	<b>BN 132M</b>	2	2930	30	89.0	88.5	0.86	17.3	6.9	2.8	2.3	178	53	<b>FD 56</b>	75	—	430	189	66	<b>FA 06</b>	75	430	189	67	<b>BA 140</b>	150	400	228	85
11	<b>BN 160MR</b>	2	2920	36	89.1	88.9	0.88	20.2	7.0	2.9	2.5	210	65																
15	<b>BN 160MB</b>	2	2930	49	89.6	89.4	0.86	28.1	7.1	2.6	2.3	340	84																
18.5	<b>BN 160L</b>	2	2930	60	90.4	90.1	0.86	34	7.6	2.7	2.3	420	97																
22	<b>BN 180M</b>	2	2930	72	91.3	91.3	0.88	40	7.8	2.6	2.4	490	109																
30	<b>BN 200LA</b>	2	2930	98	91.9	91.4	0.89	53	7.9	2.7	2.9	770	140																

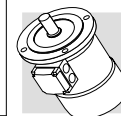







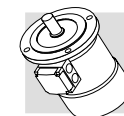

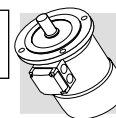





Pn kW		n min <sup>-1</sup>	Mn Nm	η %	cos φ	In [400V] A	Is In	Ms Mn	Ma Mn	Jm x 10 <sup>-4</sup> kgm <sup>2</sup>	IM B5 	freno c.c. / d.c. brake G.S.-bremse / frein c.c.					freno c.a. / a.c. brake W.S.-bremse / frein c.a.											
												FD		FA		BA												
												Mod.	Mb Nm	Z <sub>o</sub> 1/h NB SB	Jm x 10 <sup>-4</sup> kgm <sup>2</sup>	IM B5 	Mod.	Mb Nm	Z <sub>o</sub> 1/h	Jm x 10 <sup>-4</sup> kgm <sup>2</sup>	IM B5 	Mod.	Mb max Nm	Z <sub>o</sub> 1/h	Jm x 10 <sup>-4</sup> kgm <sup>2</sup>	IM B5 		
0.09	<b>BN 63A</b>	6	880	0.98	41	0.53	0.60	2.1	2.1	1.8	3.4	4.6	<b>FD 02</b>	3.5	9000	14000	4.0	6.3	<b>FA 02</b>	3.5	14000	4.0	6.1	<b>BA 60</b>	5	12000	5.4	6.9
0.12	<b>BN 63B</b>	6	870	1.32	45	0.60	0.64	2.1	1.9	1.7	3.7	4.9	<b>FD 02</b>	3.5	9000	14000	4.3	6.6	<b>FA 02</b>	3.5	14000	4.3	6.4	<b>BA 60</b>	5	12000	5.7	7.2
0.18	<b>BN 71A</b>	6	900	1.91	56	0.69	0.67	2.6	1.9	1.7	8.4	5.5	<b>FD 03</b>	5.0	8100	13500	9.5	8.2	<b>FA 03</b>	5.0	13500	9.5	7.9	<b>BA 70</b>	8	12300	10.4	9.4
0.25	<b>BN 71B</b>	6	900	2.7	62	0.71	0.82	2.6	1.9	1.7	10.9	6.7	<b>FD 03</b>	5.0	7800	13000	12	9.4	<b>FA 03</b>	5.0	13000	12	9.1	<b>BA 70</b>	8	12000	12.9	10.6
0.37	<b>BN 71C</b>	6	910	3.9	66	0.69	1.17	3	2.4	2.0	12.9	7.7	<b>FD 53</b>	7.5	5100	9500	14	10.4	<b>FA 03</b>	7.5	9500	14	10.1	<b>BA 70</b>	8	8900	14.9	11.6
0.37	<b>BN 80A</b>	6	910	3.9	68	0.68	1.15	3.2	2.2	2.0	21	9.9	<b>FD 04</b>	10	5200	8500	23	13.8	<b>FA 04</b>	10	8500	23	13.7	<b>BA 80</b>	18	8000	24	15.2
0.55	<b>BN 80B</b>	6	920	5.7	70	0.69	1.64	3.9	2.6	2.2	25	11.3	<b>FD 04</b>	15	4800	7200	27	15.2	<b>FA 04</b>	15	7200	27	15.1	<b>BA 80</b>	18	6800	28	16.6
0.75	<b>BN 80C</b>	6	920	7.8	70	0.65	2.38	3.8	2.5	2.2	28	12.2	<b>FD 04</b>	15	3400	6400	30	16.1	<b>FA 04</b>	15	6400	30	16.0	<b>BA 80</b>	18	6100	31	17.5
0.75	<b>BN 90S</b>	6	920	7.8	69	0.68	2.31	3.8	2.4	2.2	26	12.6	<b>FD 14</b>	15	3400	6500	28	16.8	<b>FA 14</b>	15	6500	28	16.7	<b>BA 90</b>	35	5500	33	19.9
1.1	<b>BN 90L</b>	6	920	11.4	72	0.69	3.2	3.9	2.3	2.0	33	15	<b>FD 05</b>	26	2700	5000	37	21	<b>FA 05</b>	26	5000	37	22	<b>BA 90</b>	35	4600	40	22
1.5	<b>BN 100LA</b>	6	940	15.2	73	0.72	4.1	4	2.1	2.0	82	22	<b>FD 15</b>	40	1900	4100	86	28	<b>FA 15</b>	40	4100	86	29	<b>BA 100</b>	50	3800	94	32
1.85	<b>BN 100LB</b>	6	930	19.0	75	0.73	4.9	4.5	2.1	2.0	95	24	<b>FD 15</b>	40	1700	3600	99	30	<b>FA 15</b>	40	3600	99	31	<b>BA 100</b>	50	3400	107	34
2.2	<b>BN 112M</b>	6	940	22	78	0.73	5.6	4.8	2.2	2.0	168	32	<b>FD 06S</b>	60	—	2100	177	42	<b>FA 06S</b>	60	2100	177	44	<b>BA 110</b>	75	2000	184	45
3	<b>BN 132S</b>	6	940	30	76	0.76	7.5	4.8	1.9	1.8	216	36	<b>FD 56</b>	75	—	1400	226	49	<b>FA 06</b>	75	1400	226	50	<b>BA 140</b>	150	1200	266	68
4	<b>BN 132MA</b>	6	950	40	78	0.77	9.6	5.5	2.0	1.8	295	45	<b>FD 06</b>	100	—	1200	305	58	<b>FA 07</b>	100	1200	318	63	<b>BA 140</b>	150	1050	345	77
5.5	<b>BN 132MB</b>	6	945	56	80	0.78	12.7	5.9	2.1	1.9	383	56	<b>FD 07</b>	150	—	1050	406	72	<b>FA 07</b>	150	1050	406	74	<b>BA 140</b>	150	1000	433	88
7.5	<b>BN 160M</b>	6	955	75	84	0.81	15.9	5.9	2.2	2.0	740	83	<b>FD 08</b>	170	—	900	815	112	<b>FA 08</b>	170	900	815	113					
11	<b>BN 160L</b>	6	960	109	87	0.81	22.5	6.5	2.5	2.3	970	103	<b>FD 08</b>	200	—	800	1045	133	<b>FA 08</b>	200	800	1045	133					
15	<b>BN 180L</b>	6	970	148	88	0.82	30	6.2	2.0	2.4	1550	130	<b>FD 09</b>	300	—	600	1750	170										
18.5	<b>BN 200LA</b>	6	960	184	88	0.81	37	5.9	2.0	2.3	1700	145	<b>FD 09</b>	400	—	450	1900	185										







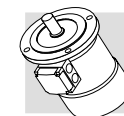

**2/4 P****3000/1500 min<sup>-1</sup> - S1****50 Hz**

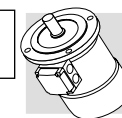
Pn kW		n min <sup>-1</sup>	Mn Nm	η %	cos φ	In [400V] A	Is In	Ms Mn	Ma Mn	Jm x 10 <sup>-4</sup> kgm <sup>2</sup>	IM B5 	freno c.c. / d.c. brake G.S.-bremse / frein c.c.						freno c.a. / a.c. brake W.S.-bremse / frein c.a.										
												FD				FA				BA								
												Mod.	Mb Nm	Zo 1/h NB SB	Jm x 10 <sup>-4</sup> kgm <sup>2</sup>	IM B5 	Mod.	Mb Nm	Zo 1/h	Jm x 10 <sup>-4</sup> kgm <sup>2</sup>	IM B5 	Mod.	Mb max Nm	Zo 1/h	Jm x 10 <sup>-4</sup> kgm <sup>2</sup>	IM B5 		
0.20 0.15	<b>BN 63B</b>	2 4	2700 1350	0.71 1.06	55 49	0.82 0.67	0.64 0.66	3.5 2.6	2.1 1.8	1.9 1.7	2.9	4.4	<b>FD 02</b>	3.5	2200 4000	2600 5100	3.5	6.1	<b>FA 02</b>	3.5	2600 5100	3.5	5.9	<b>BA 60</b>	5	2000 4000	4.9	6.7
0.28 0.20	<b>BN 71A</b>	2 4	2700 1370	0.99 1.39	56 59	0.82 0.72	0.88 0.68	2.9 3.1	1.9 1.8	1.7 1.7	4.7	4.4	<b>FD 03</b>	3.5	2100 3800	2400 4800	5.8	7.1	<b>FA 03</b>	3.5	2400 4800	5.8	6.8	<b>BA 70</b>	8	2100 4200	5.6	8.3
0.37 0.25	<b>BN 71B</b>	2 4	2740 1390	1.29 1.72	56 60	0.82 0.73	1.16 0.82	3.5 3.3	1.8 2.0	1.8 1.9	5.8	5.1	<b>FD 03</b>	5	1400 2900	2100 4200	6.9	7.8	<b>FA 03</b>	5	2100 4200	6.9	7.5	<b>BA 70</b>	8	1800 3600	7.8	9.0
0.45 0.30	<b>BN 71C</b>	2 4	2780 1400	1.55 2.0	63 63	0.85 0.73	1.21 0.94	3.8 3.6	1.8 2.0	1.8 1.9	6.9	5.9	<b>FD 03</b>	5	1400 2900	2100 4200	8.0	8.6	<b>FA 03</b>	5	2100 4200	8.0	8.3	<b>BA 70</b>	8	1800 3600	8.9	9.8
0.55 0.37	<b>BN 80A</b>	2 4	2800 1400	1.9 2.5	63 67	0.85 0.79	1.48 1.01	3.9 4.1	1.7 1.8	1.7 1.9	15	8.2	<b>FD 04</b>	5	1600 3000	2300 4000	16.6	12.1	<b>FA 04</b>	5	2300 4000	16.6	12.0	<b>BA 80</b>	18	2100 3700	18	13.5
0.75 0.55	<b>BN 80B</b>	2 4	2780 1400	2.6 3.8	65 68	0.85 0.81	1.96 1.44	3.8 3.9	1.9 1.7	1.8 1.7	20	9.9	<b>FD 04</b>	10	1400 2700	1600 3600	22	13.8	<b>FA 04</b>	10	1600 3600	22	13.7	<b>BA 80</b>	18	1500 3300	22	15.2
1.1 0.75	<b>BN 90S</b>	2 4	2790 1390	3.8 5.2	71 66	0.82 0.79	2.73 2.08	4.7 4.6	2.3 2.4	2.0 2.2	21	12.2	<b>FD 14</b>	10	1500 2300	1600 2800	23	16.4	<b>FA 14</b>	10	1600 2800	23	16.3	<b>BA 90</b>	35	1300 2300	28	19.5
1.5 1.1	<b>BN 90L</b>	2 4	2780 1390	5.2 7.6	70 73	0.85 0.81	3.64 2.69	4.5 4.7	2.4 2.5	2.1 2.2	28	14.0	<b>FD 05</b>	26	1050 1600	1200 2000	32	20	<b>FA 05</b>	26	1200 2000	32	21	<b>BA 90</b>	35	1100 1800	35	21
2.2 1.5	<b>BN 100LA</b>	2 4	2800 1410	7.5 10.2	72 73	0.85 0.79	5.2 3.8	4.5 4.7	2.0 2.0	1.9 2.0	40	18.3	<b>FD 15</b>	26	600 1300	900 2300	44	25	<b>FA 15</b>	26	900 2300	44	25	<b>BA 100</b>	50	750 1900	51	29
3.5 2.5	<b>BN 100LB</b>	2 4	2850 1420	11.7 16.8	80 82	0.84 0.80	7.5 5.5	5.4 5.2	2.2 2.2	2.1 2.2	61	25	<b>FD 15</b>	40	500 1000	900 2100	65	31	<b>FA 15</b>	40	900 2100	65	32	<b>BA 100</b>	50	750 1800	72	35
4 3.3	<b>BN 112M</b>	2 4	2880 1420	13.3 22.2	79 80	0.83 0.80	8.8 7.4	6.1 5.1	2.4 2.1	2.0 2.0	98	30	<b>FD 06S</b>	60	— —	700 1200	107	40	<b>FA 06S</b>	60	700 1200	107	42	<b>BA 110</b>	75	600 1100	114	43
5.5 4.4	<b>BN 132S</b>	2 4	2890 1440	18.2 29	80 82	0.87 0.84	11.4 9.2	5.9 5.3	2.4 2.2	2.0 2.0	213	44	<b>FD 56</b>	75	— —	350 900	223	57	<b>FA 06</b>	75	350 900	223	58	<b>BA 140</b>	150	300 750	263	76
7.5 6	<b>BN 132MA</b>	2 4	2900 1430	25 40	82 84	0.87 0.85	15.2 12.1	6.5 5.8	2.4 2.3	2.0 2.1	270	53	<b>FD 06</b>	100	— —	350 900	280	66	<b>FA 07</b>	100	350 900	293	71	<b>BA 140</b>	150	300 800	320	85
9.2 7.3	<b>BN 132MB</b>	2 4	2920 1440	30 48	83 85	0.86 0.85	18.6 14.6	6.0 5.5	2.6 2.3	2.2 2.1	319	59	<b>FD 07</b>	150	— —	300 800	342	75	<b>FA 07</b>	150	300 800	342	77	<b>BA 140</b>	150	300 750	369	91

Pn kW		n min <sup>-1</sup>	Mn Nm	η %	cos φ	In [400V] A	Is In	Ms Mn	Ma Mn	Jm x 10 <sup>-4</sup> kgm <sup>2</sup>	IM B5 	freno c.c. / d.c. brake G.S.-bremse / frein c.c.						freno c.a. / a.c. brake W.S.-bremse / frein c.a.										
												FD			FA			BA										
												Mod.	Mb Nm	Zo 1/h NB SB	Jm x 10 <sup>-4</sup> kgm <sup>2</sup>	IM B5 	Mod.	Mb Nm	Zo 1/h	Jm x 10 <sup>-4</sup> kgm <sup>2</sup>	IM B5 	Mod.	Mb max Nm	Zo 1/h	Jm x 10 <sup>-4</sup> kgm <sup>2</sup>	IM B5 		
0.25 0.08	<b>BN 71A</b>	2 6	2850 910	0.84 0.84	60 43	0.82 0.70	0.73 0.38	4.3 2.1	1.9 1.4	1.8 1.5	6.9 5.9	5.9	<b>FD 03</b>	1.75	1500 10000	1700 13000	8.0	8.6	<b>FA 03</b>	2.5	1700 13000	8.0	8.3	<b>BA 70</b>	8	1500 11000	8.9	9.8
0.37 0.12	<b>BN 71B</b>	2 6	2880 900	1.23 1.27	62 44	0.80 0.73	1.08 0.54	4.4 2.4	1.9 1.4	1.8 1.5	9.1 7.3	7.3	<b>FD 03</b>	3.5	1000 9000	1300 11000	10.2	10.0	<b>FA 03</b>	3.5	1300 11000	10.2	9.7	<b>BA 70</b>	8	1200 10000	11.1	11.2
0.55 0.18	<b>BN 80A</b>	2 6	2800 930	1.88 1.85	63 52	0.86 0.65	1.47 0.77	4.5 3.3	1.9 2	1.7 1.9	20 9.9	9.9	<b>FD 04</b>	5	1500 4100	1800 6300	22	13.8	<b>FA 04</b>	5	1800 6300	22	13.7	<b>BA 80</b>	18	1700 6000	23	15.2
0.75 0.25	<b>BN 80B</b>	2 6	2800 930	2.6 2.6	66 54	0.87 0.67	1.89 1.00	4.3 3.2	1.8 1.7	1.6 1.8	25 11.3	11.3	<b>FD 04</b>	5	1700 3800	1900 6000	27	15.2	<b>FA 04</b>	5	1900 6000	27	15.1	<b>BA 80</b>	18	1800 5600	28	16.6
1.1 0.37	<b>BN 90L</b>	2 6	2860 920	3.7 3.8	67 59	0.84 0.71	2.82 1.27	4.7 3.3	2.1 1.6	1.9 1.6	28 14.0	14.0	<b>FD 05</b>	13	1400 3400	1600 5200	32	20	<b>FA 05</b>	13	1600 5200	32	21	<b>BA 90</b>	35	1500 4700	35	21
1.5 0.55	<b>BN 100LA</b>	2 6	2880 940	5.0 5.6	73 64	0.84 0.67	3.53 1.85	5.1 3.5	1.9 1.7	2.0 1.8	40 18.3	18.3	<b>FD 15</b>	13	1000 2900	1200 4000	44	24	<b>FA 15</b>	13	1200 4000	44	25	<b>BA 100</b>	50	1050 3500	51	29
2.2 0.75	<b>BN 100LB</b>	2 6	2900 950	7.2 7.5	77 67	0.85 0.64	4.9 2.5	5.9 3.3	2.0 1.9	2.0 1.8	61 25	25	<b>FD 15</b>	26	700 2100	900 3000	65	31	<b>FA 15</b>	26	900 3000	65	32	<b>BA 100</b>	50	800 2700	72	36
3 1.1	<b>BN 112M</b>	2 6	2900 950	9.9 11.1	78 72	0.87 0.64	6.4 3.4	6.3 3.9	2.0 1.8	2.1 1.8	98 30	30	<b>FD 06S</b>	40	— —	1000 2600	107	40	<b>FA 06S</b>	40	1000 2600	107	32	<b>BA 110</b>	75	930 2400	114	43
4.5 1.5	<b>BN 132S</b>	2 6	2910 960	14.8 14.9	78 74	0.84 0.67	9.9 4.4	5.8 4.2	1.9 1.9	1.8 2.0	213 44	44	<b>FD 56</b>	37	— —	500 2100	223	57	<b>FA 06</b>	37	500 2100	223	58	<b>BA 140</b>	150	400 1700	263	76
5.5 2.2	<b>BN 132M</b>	2 6	2920 960	18.0 22	78 77	0.87 0.71	11.7 5.8	6.2 4.3	2.1 2.1	1.9 2.0	270 53	53	<b>FD 56</b>	50	— —	400 1900	280	66	<b>FA 06</b>	50	400 1900	280	67	<b>BA 140</b>	150	350 1600	320	85







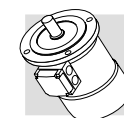

**2/8 P****3000/750 min<sup>-1</sup> - S3 60/40%****50 Hz**

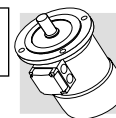
Pn kW		n min <sup>-1</sup>	Mn Nm	η %	cos φ	In [400V] A	Is In	Ms Mn	Ma Mn	Jm x 10 <sup>-4</sup> kgm <sup>2</sup>	IM B5 	freno c.c. / d.c. brake G.S.-bremse / frein c.c.						freno c.a. / a.c. brake W.S.-bremse / frein c.a.										
												FD						FA				BA						
												Mod.	Mb Nm	Zo 1/h NB SB		Jm x 10 <sup>-4</sup> kgm <sup>2</sup>	IM B5 	Mod.	Mb Nm	Zo 1/h	Jm x 10 <sup>-4</sup> kgm <sup>2</sup>	IM B5 	Mod.	Mb max Nm	Zo 1/h	Jm x 10 <sup>-4</sup> kgm <sup>2</sup>	IM B5 	
0.25 0.06	<b>BN 71A</b>	<b>2</b> <b>8</b>	2790 680	0.86 0.84	61 31	0.87 0.61	0.68 0.46	3.9 2	1.8 1.8	1.9 1.9	10.9	6.7	<b>FD 03</b>	1.75	1300 10000	1400 13000	12	9.4	<b>FA 03</b>	2.5	1400 13000	12	9.1	<b>BA 70</b>	8	1300 12000	12.9	10.6
0.37 0.09	<b>BN 71B</b>	<b>2</b> <b>8</b>	2800 670	1.26 1.28	63 34	0.86 0.75	0.99 0.51	3.9 1.8	1.8 1.4	1.9 1.5	12.9	7.7	<b>FD 03</b>	3.5	1200 9500	1300 13000	14	10.4	<b>FA 03</b>	3.5	1300 13000	14	10.1	<b>BA 70</b>	8	1200 12000	14.9	11.6
0.55 0.13	<b>BN 80A</b>	<b>2</b> <b>8</b>	2830 690	1.86 1.80	66 41	0.86 0.64	1.40 0.72	4.4 2.3	2.1 1.6	2.0 1.7	20	9.9	<b>FD 04</b>	5	1500 5600	1800 8000	22	13.8	<b>FA 04</b>	5	1800 8000	22	13.7	<b>BA 80</b>	18	1700 7500	23	15.2
0.75 0.18	<b>BN 80B</b>	<b>2</b> <b>8</b>	2800 690	2.6 2.5	68 43	0.88 0.66	1.81 0.92	4.6 2.3	2.1 1.6	2.0 1.7	25	11.3	<b>FD 04</b>	10	1700 4800	1900 7300	27	15.2	<b>FA 04</b>	10	1900 7300	27	15.1	<b>BA 80</b>	18	1800 7000	28	16.6
1.1 0.28	<b>BN 90L</b>	<b>2</b> <b>8</b>	2830 690	3.7 3.9	63 48	0.84 0.63	3.00 1.34	4.5 2.4	2.1 1.8	1.9 1.9	28	14	<b>FD 05</b>	13	1400 3400	1600 5100	32	20	<b>FA 05</b>	13	1600 5100	32	21	<b>BA 90</b>	35	1400 4500	35	21
1.5 0.37	<b>BN 100LA</b>	<b>2</b> <b>8</b>	2880 690	5.0 5.1	69 46	0.85 0.63	3.69 1.84	4.7 2.1	1.9 1.6	1.8 1.6	40	18.3	<b>FD 15</b>	13	1000 3300	1200 5000	44	25	<b>FA 15</b>	13	1200 5000	44	25	<b>BA 100</b>	50	1000 4200	52	29
2.4 0.55	<b>BN 100LB</b>	<b>2</b> <b>8</b>	2900 700	7.9 7.5	75 54	0.82 0.58	5.6 2.5	5.4 2.6	2.1 1.8	2.0 1.8	61	25	<b>FD 15</b>	26	550 2000	700 3500	65	31	<b>FA 15</b>	26	700 3500	65	32	<b>BA 100</b>	50	600 3100	72	36
3 0.75	<b>BN 112M</b>	<b>2</b> <b>8</b>	2900 690	9.9 10.4	76 60	0.87 0.65	6.5 2.8	6.3 2.5	2.1 1.6	1.9 1.6	98	30	<b>FD 06S</b>	40	— —	900 2900	107	40	<b>FA 06S</b>	40	900 2900	107	42	<b>BA 110</b>	75	800 2700	114	43
4 1	<b>BN 132S</b>	<b>2</b> <b>8</b>	2870 690	13.3 13.8	73 66	0.84 0.62	9.4 3.5	5.6 2.9	2.3 1.9	2.4 1.8	213	44	<b>FD 56</b>	37	— —	500 3500	223	57	<b>FA 06</b>	37	500 3500	223	58	<b>BA 140</b>	150	400 3000	263	76
5.5 1.5	<b>BN 132M</b>	<b>2</b> <b>8</b>	2870 690	18.3 21	75 68	0.84 0.63	12.6 5.1	6.1 2.9	2.4 1.9	2.5 1.9	270	53	<b>FD 06</b>	50	— —	400 2400	280	66	<b>FA 06</b>	50	400 2400	280	67	<b>BA 140</b>	150	350 2100	320	85

Pn kW		n min <sup>-1</sup>	Mn Nm	η %	cos φ	In [400V] A	Is In	Ms Mn	Ma Mn	Jm x 10 <sup>-4</sup> kgm <sup>2</sup>	IM B5 	freno c.c. / d.c. brake G.S.-bremse / frein c.c.					freno c.a. / a.c. brake W.S.-bremse / frein c.a.											
												FD					FA					BA						
												Mod.	Mb Nm	Zo 1/h NB SB	Jm x 10 <sup>-4</sup> kgm <sup>2</sup>	IM B5 	Mod.	Mb Nm	Zo 1/h	Jm x 10 <sup>-4</sup> kgm <sup>2</sup>	IM B5 	Mod.	Mb max Nm	Zo 1/h	Jm x 10 <sup>-4</sup> kgm <sup>2</sup>	IM B5 		
0.55 0.09	<b>BN 80B</b>	<b>2</b> <b>12</b>	2820 430	1.86 2.0	64 30	0.89 0.63	1.39 0.69	4.2 1.8	1.6 1.9	1.7 1.8	25	11.3	<b>FD 04</b>	5	1000 8000	1300 12000	27	15.2	<b>FA 04</b>	5	1300 12000	27	15.1	<b>BA 80</b>	18	1200 11000	28	16.6
0.75 0.12	<b>BN 90L</b>	<b>2</b> <b>12</b>	2790 430	2.6 2.7	56 26	0.89 0.63	2.17 1.06	4.2 1.7	1.8 1.4	1.7 1.6	26	12.6	<b>FD 05</b>	13	1000 4600	1150 6300	30	18.6	<b>FA 05</b>	13	1150 6300	30	19.3	<b>BA 90</b>	35	1050 5700	33	19.9
1.1 0.18	<b>BN 100LA</b>	<b>2</b> <b>12</b>	2850 430	3.7 4.0	65 26	0.85 0.54	2.87 1.85	4.5 1.5	1.6 1.3	1.8 1.5	40	18.3	<b>FD 15</b>	13	700 4000	900 6000	44	25	<b>FA 15</b>	13	900 6000	44	25	<b>BA 100</b>	50	750 5000	52	29
1.5 0.25	<b>BN 100LB</b>	<b>2</b> <b>12</b>	2900 440	4.9 5.4	67 36	0.86 0.46	3.76 2.18	5.6 1.8	1.9 1.7	1.9 1.8	54	22	<b>FD 15</b>	13	700 3800	900 5000	58	28	<b>FA 15</b>	13	900 5000	58	29	<b>BA 100</b>	50	800 4300	66	32
2 0.3	<b>BN 112M</b>	<b>2</b> <b>12</b>	2900 460	6.6 6.2	74 46	0.88 0.43	4.43 2.19	6.5 2	2.1 2.1	2 2	98	30	<b>FD 06S</b>	20	— —	800 3400	107	40	<b>FA 06S</b>	20	800 3400	107	42	<b>BA 110</b>	75	750 3200	114	43
3 0.5	<b>BN 132S</b>	<b>2</b> <b>12</b>	2920 470	9.8 10.2	74 51	0.87 0.43	6.7 3.3	6.8 2	2.3 1.7	1.9 1.6	213	44	<b>FD 56</b>	37	— —	450 3000	223	57	<b>FA 06</b>	37	450 3000	223	58	<b>BA 140</b>	150	380 2500	263	76
4 0.7	<b>BN 132M</b>	<b>2</b> <b>12</b>	2920 460	13.1 14.5	75 53	0.89 0.44	8.6 4.3	5.9 1.9	2.4 1.7	2.3 1.6	270	53	<b>FD 56</b>	37	— —	400 2800	280	66	<b>FA 06</b>	37	400 2800	280	67	<b>BA 140</b>	150	350 2500	320	85







**4/6 P****1500/1000 min<sup>-1</sup> - S1****50 Hz**

Pn kW		n min <sup>-1</sup>	Mn Nm	η %	cos φ	In [400V] A	Is In	Ms Mn	Ma Mn	Jm x 10 <sup>-4</sup> kgm <sup>2</sup>	IM B5 	freno c.c. / d.c. brake G.S.-bremse / frein c.c.					freno c.a. / a.c. brake W.S.-bremse / frein c.a.											
												FD					FA					BA						
												Mod.	Mb Nm	Zo 1/h NB SB	Jm x 10 <sup>-4</sup> kgm <sup>2</sup>	IM B5 	Mod.	Mb Nm	Zo 1/h	Jm x 10 <sup>-4</sup> kgm <sup>2</sup>	IM B5 	Mod.	Mb max Nm	Zo 1/h	Jm x 10 <sup>-4</sup> kgm <sup>2</sup>	IM B5 		
0.22 0.13	<b>BN 71B</b>	4 6	1410 920	1.5 1.4	64 43	0.74 0.67	0.67 0.65	3.9 2.3	1.8 1.6	1.9 1.7	9.1	7.3	<b>FD 03</b>	3.5	2500 5000	3500 9000	10.2	10	<b>FA 03</b>	3.5	3500 9000	10.2	9.7	<b>BA 70</b>	8	3200 8200	11.1	11.2
0.30 0.20	<b>BN 80A</b>	4 6	1410 930	2.0 2.1	61 54	0.82 0.66	0.87 0.81	3.5 3.2	1.3 1.9	1.5 2.0	15	8.2	<b>FD 04</b>	5	2500 4000	3100 6000	16.6	12.1	<b>FA 04</b>	5	3100 6000	16.6	12.0	<b>BA 80</b>	18	2800 5500	18	13.5
0.40 0.26	<b>BN 80B</b>	4 6	1430 930	2.7 2.7	63 55	0.75 0.70	1.22 0.97	3.9 2.7	1.8 1.5	1.8 1.6	20	9.9	<b>FD 04</b>	10	1800 3600	2300 5500	22	13.8	<b>FA 04</b>	10	2300 5500	22	13.7	<b>BA 80</b>	18	2200 5200	23	15.2
0.55 0.33	<b>BN 90S</b>	4 6	1420 930	3.7 3.4	70 62	0.78 0.70	1.45 1.10	4.5 3.7	2.0 2.3	1.9 2.0	21	12.2	<b>FD 14</b>	10	1500 2500	2100 4100	23	16.1	<b>FA 14</b>	10	2100 4100	23	16.3	<b>BA 90</b>	35	1700 3300	28	19.5
0.75 0.45	<b>BN 90L</b>	4 6	1420 920	5.0 4.7	74 66	0.78 0.71	1.88 1.39	4.3 3.3	1.9 2.0	1.8 1.9	28	14	<b>FD 05</b>	13	1400 2300	2000 3600	32	20	<b>FA 05</b>	13	2000 3600	32	21	<b>BA 90</b>	35	1800 3300	35	21
1.1 0.8	<b>BN 100LA</b>	4 6	1450 950	7.2 8.0	74 65	0.79 0.69	2.72 2.57	5.0 4.1	1.7 1.9	1.9 2.1	82	22	<b>FD 15</b>	26	1400 2100	2000 3300	86	28	<b>FA 15</b>	26	2000 3300	86	29	<b>BA 100</b>	50	1800 3000	94	32
1.5 1.1	<b>BN 100LB</b>	4 6	1450 950	9.9 11.1	75 72	0.79 0.68	3.65 3.24	5.1 4.3	1.7 2.0	1.9 2.1	95	25	<b>FD 15</b>	26	1300 2000	1800 3000	99	31	<b>FA 15</b>	26	1800 3000	99	32	<b>BA 100</b>	50	1600 2800	107	34
2.3 1.5	<b>BN 112M</b>	4 6	1450 960	15.2 14.9	75 73	0.78 0.72	5.7 4.1	5.2 4.9	1.8 2.0	1.9 2.0	168	32	<b>FD 06S</b>	40	— —	1600 2400	177	42	<b>FA 06S</b>	40	1600 2400	177	44	<b>BA 110</b>	75	1500 2300	184	45
3.1 2	<b>BN 132S</b>	4 6	1460 960	20 20	83 77	0.83 0.75	6.5 4.9	5.9 4.5	2.1 2.1	2.0 2.1	213	44	<b>FD 56</b>	37	— —	1200 1900	223	57	<b>FA 06</b>	37	1200 1900	223	58	<b>BA 140</b>	150	1000 1600	263	76
4.2 2.6	<b>BN 132MA</b>	4 6	1460 960	27 26	84 79	0.82 0.72	8.8 6.6	5.9 4.3	2.1 2.0	2.2 2.0	270	53	<b>FD 06</b>	50	— —	900 1500	280	66	<b>FA 06</b>	50	900 1500	280	67	<b>BA 140</b>	150	800 1300	320	85

# 4/8 P

## 1500/750 min<sup>-1</sup> - S1



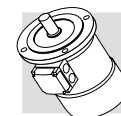

## 50 Hz

Pn kW		n min <sup>-1</sup>	Mn Nm	η %	cos φ	In [400V] A	Is In	Ms Mn	Ma Mn	Jm x 10 <sup>-4</sup> kgm <sup>2</sup>	IM B5  Kg	freno c.c. / d.c. brake G.S.-bremse / frein c.c.					freno c.a. / a.c. brake W.S.-bremse / frein c.a.											
												FD					FA					BA						
												Mod.	Mb Nm	Zo 1/h	Jm x 10 <sup>-4</sup> kgm <sup>2</sup>	IM B5  Kg	Mod.	Mb Nm	Zo 1/h	Jm x 10 <sup>-4</sup> kgm <sup>2</sup>	IM B5  Kg	Mod.	Mb max Nm	Zo 1/h	Jm x 10 <sup>-4</sup> kgm <sup>2</sup>	IM B5  Kg		
0.37 0.18	<b>BN 80A</b>	4 8	1400 690	2.5 2.5	63 44	0.82 0.60	1.03 0.98	3.3 2.2	1.4 1.5	1.4 1.6	15	8.2	<b>FD 04</b>	10	2300 4500	3500 7000	16.6	12.1	<b>FA 04</b>	10	3500 7000	16.6	12.0	<b>BA 80</b>	18	3200 6500	18	13.5
0.55 0.30	<b>BN 80B</b>	4 8	1390 670	3.8 4.3	65 49	0.86 0.65	1.42 1.36	3.8 2.3	1.7 1.7	1.6 1.8	20	9.9	<b>FD 04</b>	10	2200 4200	2900 6500	22	13.8	<b>FA 04</b>	10	2900 6500	22	13.7	<b>BA 80</b>	18	2500 5600	23	15.2
0.65 0.35	<b>BN 90S</b>	4 8	1390 690	4.5 4.8	73 49	0.85 0.57	1.51 1.81	4.0 2.5	1.9 2.1	1.9 2.2	28	13.6	<b>FD 14</b>	15	2300 3500	2800 6000	30	17.8	<b>FA 14</b>	15	2800 6000	30	17.7	<b>BA 90</b>	35	2400 5100	35	21
0.9 0.5	<b>BN 90L</b>	4 8	1370 670	6.3 7.1	73 57	0.87 0.62	2.05 2.04	3.8 2.4	1.8 2.1	1.8 2	30	15.1	<b>FD 05</b>	26	1700 2500	2100 4200	34	21	<b>FA 05</b>	26	2100 4200	34	22	<b>BA 90</b>	35	1900 3800	37	22
1.3 0.7	<b>BN 100LA</b>	4 8	1420 700	8.7 9.6	72 58	0.83 0.64	3.14 2.72	4.3 2.8	1.7 1.8	1.8 1.8	82	22	<b>FD 15</b>	40	1300 2000	1700 3400	86	28	<b>FA 15</b>	40	1700 3400	86	29	<b>BA 100</b>	50	1500 3100	94	32
1.8 0.9	<b>BN 100LB</b>	4 8	1420 700	12.1 12.3	69 62	0.87 0.63	4.3 3.3	4.2 3.2	1.6 1.7	1.7 1.8	95	25	<b>FD 15</b>	40	1200 1600	1700 2600	99	31	<b>FA 15</b>	40	1700 2600	99	32	<b>BA 100</b>	50	1500 2400	107	34
2.2 1.2	<b>BN 112M</b>	4 8	1440 710	14.6 16.1	77 70	0.85 0.63	4.9 3.9	5.3 3.3	1.8 1.9	1.8 1.8	168	32	<b>FD 06S</b>	60	— —	1200 2000	177	42	<b>FA 06S</b>	60	1200 2000	177	43	<b>BA 110</b>	75	1100 1900	184	45
3.6 1.8	<b>BN 132S</b>	4 8	1440 720	24 24	80 72	0.82 0.55	7.9 6.6	6.5 4.6	2.1 1.9	1.9 2	295	45	<b>FD 56</b>	75	— —	1000 1400	305	58	<b>FA 06</b>	75	1000 1400	305	59	<b>BA 140</b>	150	900 1200	345	77
4.6 2.3	<b>BN 132M</b>	4 8	1450 720	30 31	81 73	0.83 0.54	9.9 8.4	6.5 4.4	2.2 2.3	1.9 2	383	56	<b>FD 06</b>	100	— —	1000 1300	393	69	<b>FA 07</b>	100	1000 1300	406	74	<b>BA 140</b>	150	900 1200	433	88





**2 P****3000 min<sup>-1</sup> - S1****50 Hz**





Pn kW		n min <sup>-1</sup>	Mn Nm	$\eta$ (100%) %	$\eta$ (75%) %	cos $\varphi$	In [400V] A	$\frac{I_s}{I_n}$	$\frac{M_s}{M_n}$	$\frac{M_a}{M_n}$	Jm $\times 10^{-4}$ kgm <sup>2</sup>	IM B9 	freno c.c. / d.c. brake G.S.-bremse / frein c.c.					freno c.a. / a.c. brake W.S.-bremse / frein c.a.					
													FD					FA					
													Mod.	Mb Nm	Z <sub>o</sub> 1/h NB SB		Jm $\times 10^{-4}$ Kgm <sup>2</sup>	IM B9 	Mod.	Mb Nm	Z <sub>o</sub> 1/h	Jm $\times 10^{-4}$ kgm <sup>2</sup>	IM B9 
0.18	<b>M 05A</b>	2	2730	0.63	59.9	0.77	0.56	3.0	2.1	2.0	2.0	3.2	<b>FD 02</b>	1.75	3900	4800	2.6	4.9	<b>FA 02</b>	1.75	4800	2.6	4.7
0.25	<b>M 05B</b>	2	2740	0.87	66.0	0.76	0.72	3.3	2.3	2.3	2.3	3.6	<b>FD 02</b>	1.75	3900	4800	3.0	5.3	<b>FA 02</b>	1.75	4800	3.0	5.1
0.37	<b>M 05C</b>	2	2800	1.26	69.1	0.78	0.99	3.9	2.6	2.6	3.3	4.8	<b>FD 02</b>	3.5	3600	4500	3.9	6.5	<b>FA 02</b>	3.5	4500	3.9	6.3
0.55	<b>M 1SD</b>	2	2820	1.86	76.0	0.76	1.37	5	2.9	2.8	4.1	5.8	<b>FD 03</b>	5	2900	4200	5.3	8.5	<b>FA 03</b>	5	4200	5.3	8.2
0.75	<b>M 1LA</b>	2	2810	2.6	76.6	0.76	1.86	5.1	3.1	2.8	5.0	6.9	<b>FD 03</b>	5	1900	3300	6.1	9.6	<b>FA 03</b>	5	3300	6.1	9.3
1.1	<b>M 2SA</b>	2	2800	3.8	76.4	0.81	2.57	4.8	2.8	2.4	9.0	8.8	<b>FD 04</b>	10	1500	3000	10.6	11.9	<b>FA 04</b>	10	3000	10.6	12.6
1.5	<b>M 2SB</b>	2	2800	5.1	79.1	0.81	3.4	4.9	2.7	2.4	11.4	10.6	<b>FD 04</b>	15	1300	2600	13.0	9.9	<b>FA 04</b>	15	2600	13.0	14.4
2.2	<b>M 3SA</b>	2	2850	7.4	80.2	0.78	5.1	5.2	2.1	1.8	24	15.5	<b>FD 15</b>	26	1100	2400	28	22	<b>FA 15</b>	26	2400	28	23
3	<b>M 3LA</b>	2	2860	10.0	82.8	0.79	6.6	5.7	2.6	2.2	31	18.7	<b>FD 15</b>	26	700	1600	35	25	<b>FA 15</b>	26	1600	35	26
4	<b>M 3LB</b>	2	2870	13.3	84.3	0.80	8.6	5.9	2.7	2.5	39	22	<b>FD 15</b>	40	450	900	43	28	<b>FA 15</b>	40	900	43	29
5.5	<b>M 4SA</b>	2	2890	18.2	86.1	0.84	11.0	6	2.6	2.2	101	33	<b>FD 06</b>	50	—	600	112	46	<b>FA 06</b>	50	600	112	47
7.5	<b>M 4SB</b>	2	2900	25	87.2	0.85	14.6	6.4	2.6	2.2	145	40	<b>FD 06</b>	50	—	550	154	53	<b>FA 06</b>	50	550	154	54
9.2	<b>M 4LA</b>	2	2930	30	89.0	0.86	17.3	6.9	2.8	2.3	178	51	<b>FD 56</b>	75	—	430	189	64	<b>FA 06</b>	75	430	189	65
11	<b>M 4LC</b>	2	2920	36	89.1	0.88	20.2	7	2.9	2.5	210	60											
15	<b>M 5SB</b>	2	2930	49	89.6	0.86	28.1	7.1	2.6	2.3	340	70											
18.5	<b>M 5SC</b>	2	2930	60	90.4	0.86	34	7.6	2.7	2.3	420	83											
22	<b>M 5LA</b>	2	2930	72	91.3	0.88	40	7.8	2.6	2.4	490	95											

4 P

1500 min<sup>-1</sup> - S1





50 Hz

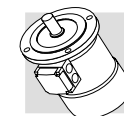

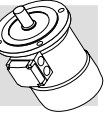



Pn kW		n min <sup>-1</sup>	Mn Nm	$\eta$ (100%) %	$\eta$ (75%) %	cos $\varphi$	In [400V] A	$\frac{I_s}{I_n}$	$\frac{M_s}{M_n}$	$\frac{M_a}{M_n}$	Jm $\times 10^{-4}$ kgm <sup>2</sup>	IM B9  Kg	freno c.c. / d.c. brake G.S.-bremse / frein c.c.					freno c.a. / a.c. brake W.S.-bremse / frein c.a.						
													FD					FA						
													Mod	Mb Nm	Z <sub>o</sub> 1/h NB SB		Jm $\times 10^{-4}$ Kgm <sup>2</sup>	IM B9  Kg	Mod.	Mb Nm	Z <sub>o</sub> 1/h	Jm $\times 10^{-4}$ kgm <sup>2</sup>	IM B9  Kg	
0.09	<b>M 0B</b>	4	1350	0.64	51.7	47.6	0.60	0.42	2.6	2.5	2.4	1.5	2.9											
0.12	<b>M 05A</b>	4	1350	0.85	59.8	56.2	0.62	0.47	2.6	1.9	1.8	2.0	3.2	<b>FD 02</b>	1.75	10000	13000	2.6	4.9	<b>FA 02</b>	1.75	13000	2.6	4.7
0.18	<b>M 05B</b>	4	1320	1.30	54.8	52.9	0.67	0.71	2.6	2.2	2.0	2.3	3.6	<b>FD 02</b>	3.5	10000	13000	3.0	5.3	<b>FA 02</b>	3.5	13000	3.0	5.1
0.25	<b>M 05C</b>	4	1340	1.78	65.3	65.0	0.69	0.80	2.7	2.1	1.9	3.3	4.8	<b>FD 02</b>	3.5	7800	10000	3.9	6.5	<b>FA 02</b>	3.5	10000	3.9	6.3
0.37	<b>M 1SD</b>	4	1370	2.6	66.8	66.7	0.76	1.05	3.7	2	1.9	6.9	5.5	<b>FD 03</b>	5	6000	9400	8.0	8.2	<b>FA 03</b>	5	9400	8.0	7.9
0.55	<b>M 1LA</b>	4	1380	3.8	69.0	68.9	0.74	1.55	4.1	2.3	2.3	9.1	6.9	<b>FD 53</b>	7.5	4300	8700	10.2	9.6	<b>FA 03</b>	7.5	8700	10.2	9.3
0.75	<b>M 2SA</b>	4	1400	5.1	75.0	74.5	0.78	1.85	4.9	2.7	2.5	20	9.2	<b>FD 04</b>	15	4100	7800	22	13.1	<b>FA 04</b>	15	7800	22	13
1.1	<b>M 2SB</b>	4	1400	7.5	76.4	76.2	0.78	2.66	5.1	2.8	2.5	25	10.6	<b>FD 04</b>	15	2600	5300	27	14.5	<b>FA 04</b>	15	5300	27	14.4
1.5	<b>M 3SA</b>	4	1410	10.2	79.6	80.5	0.77	3.5	4.6	2.1	2.1	34	15.5	<b>FD 15</b>	26	2800	4900	38	22	<b>FA 15</b>	26	4900	38	23
2.2	<b>M 3LA</b>	4	1410	14.9	81.1	81.4	0.75	5.2	4.5	2.2	2	40	17	<b>FD 15</b>	40	2600	4700	44	24	<b>FA 15</b>	40	4700	44	24
3	<b>M 3LB</b>	4	1410	20	82.6	83.8	0.77	6.8	5	2.3	2.2	54	21	<b>FD 15</b>	40	2400	4400	58	27	<b>FA 15</b>	40	4400	58	28
4	<b>M 3LC</b>	4	1400	27	82.7	83.1	0.78	9.0	4.7	2.3	2.2	61	23	<b>FD 55</b>	55	—	1300	65	29	<b>FA 15</b>	40	1300	65	30
5.5	<b>M 4SA</b>	4	1440	36	86.3	86.4	0.80	11.5	5.5	2.3	2.2	213	42	<b>FD 56</b>	75	—	1050	223	55	<b>FA 06</b>	75	1050	223	56
7.5	<b>M 4LA</b>	4	1440	50	87	87.1	0.80	15.6	5.7	2.5	2.4	270	51	<b>FD 06</b>	100	—	950	280	64	<b>FA 07</b>	100	950	280	65
9.2	<b>M 4LB</b>	4	1440	61	88.4	88.6	0.80	18.8	5.9	2.7	2.5	319	57	<b>FD 07</b>	150	—	900	342	73	<b>FA 07</b>	150	900	342	75
11	<b>M 4 LC</b>	4	1440	73	88.4	88.8	0.81	22.2	5.9	2.7	2.5	360	65	<b>FD 07</b>	150	—	850	382	81	<b>FA 07</b>	150	850	382	83
15	<b>M 5SB</b>	4	1460	98	89.9	89.4	0.81	29.7	5.9	2.3	2.1	650	85	<b>FD 08</b>	200	—	750	725	115	<b>FA 08</b>	200	750	710	114
18.5	<b>M 5LA</b>	4	1460	121	90.0	90.1	0.81	37	6.2	2.6	2.5	790	101	<b>FD 08</b>	250	—	700	865	131	<b>FA 08</b>	250	700	850	130





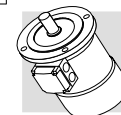

**6 P****1000 min<sup>-1</sup> - S1****50 Hz**

Pn kW		n min <sup>-1</sup>	Mn Nm	η %	cos φ	In [400V] A	Is In	Ms Mn	Ma Mn	Jm x 10 <sup>-4</sup> kgm <sup>2</sup>	IM B9 	freno c.c. / d.c. brake G.S.-bremse / frein c.c.					freno c.a. / a.c. brake W.S.-bremse / frein c.a.						
												FD					FA						
												Mod.	Mb Nm	Zo 1/h NB SB	Jm x 10 <sup>-4</sup> kgm <sup>2</sup>	IM B9 	Mod.	Mb Nm	Zo 1/h	Jm x 10 <sup>-4</sup> kgm <sup>2</sup>	IM B9 		
0.09	<b>M 05A</b>	<b>6</b>	880	0.98	41	0.53	0.60	2.1	2.1	1.8	3.4	4.3	<b>FD 02</b>	3.5	9000	14000	4.0	6.0	<b>FA 02</b>	3.5	14000	4.0	5.8
0.12	<b>M 05B</b>	<b>6</b>	870	1.32	45	0.60	0.64	2.1	1.9	1.7	3.7	4.6	<b>FD 02</b>	3.5	9000	14000	4.3	6.3	<b>FA 02</b>	3.5	14000	4.3	6.1
0.18	<b>M 1SC</b>	<b>6</b>	900	1.91	56	0.69	0.67	2.6	1.9	1.7	8.4	5.1	<b>FD 03</b>	5	8100	13500	9.5	7.8	<b>FA 03</b>	5	13500	9.5	7.5
0.25	<b>M 1SD</b>	<b>6</b>	900	2.7	62	0.71	0.82	2.6	1.9	1.7	10.9	6.3	<b>FD 03</b>	5	7800	13000	12	9	<b>FA 03</b>	5	13000	12	8.7
0.37	<b>M 1LA</b>	<b>6</b>	910	3.9	66	0.69	1.17	3	2.4	2	12.9	7.3	<b>FD 53</b>	7.5	5100	9500	14	10	<b>FA 03</b>	7.5	9500	14	9.7
0.55	<b>M 2SA</b>	<b>6</b>	920	5.7	70	0.69	1.64	3.9	2.6	2.2	25	10.6	<b>FD 04</b>	15	4800	7200	27	14.5	<b>FA 04</b>	15	7200	27	14.4
0.75	<b>M 2SB</b>	<b>6</b>	920	7.8	70	0.65	2.38	3.8	2.5	2.2	28	11.5	<b>FD 04</b>	15	3400	6400	30	15.4	<b>FA 04</b>	15	6400	30	15.3
1.1	<b>M 3SA</b>	<b>6</b>	920	11.4	72	0.69	3.2	3.9	2.3	2	33	17	<b>FD 05</b>	26	2700	5000	37	23	<b>FA 15</b>	26	5000	37	24
1.5	<b>M 3LA</b>	<b>6</b>	940	15.2	73	0.72	4.1	4	2.1	2	82	21	<b>FD 15</b>	40	1900	4100	86	27	<b>FA 15</b>	40	4100	86	28
1.85	<b>M 3LB</b>	<b>6</b>	930	19.0	75	0.73	4.9	4.5	2.1	2	95	23	<b>FD 15</b>	40	1700	3600	99	29	<b>FA 15</b>	40	3600	99	30
2.2	<b>M 3LC</b>	<b>6</b>	930	23	75	0.71	6.0	4.6	2	1.9	95	23	<b>FD 55</b>	55	—	1900	99	29	<b>FA 15</b>	55	1900	99	30
3	<b>M 4SA</b>	<b>6</b>	940	30	76	0.76	7.5	4.8	1.9	1.8	216	34	<b>FD 56</b>	75	—	1400	226	47	<b>FA 06</b>	75	1400	226	48
4	<b>M 4LA</b>	<b>6</b>	950	40	78	0.77	9.6	5.5	2	1.8	295	43	<b>FD 06</b>	100	—	1200	305	56	<b>FA 07</b>	100	1200	305	57
5.5	<b>M 4LB</b>	<b>6</b>	945	56	80	0.78	12.7	5.9	2.1	1.9	383	54	<b>FD 07</b>	150	—	1050	406	70	<b>FA 07</b>	150	1050	406	72
7.5	<b>M 5SA</b>	<b>6</b>	955	75	84	0.81	15.9	5.9	2.2	2	740	69	<b>FD 08</b>	170	—	900	815	98	<b>FA 08</b>	170	900	800	98
11	<b>M 5SB</b>	<b>6</b>	960	109	87	0.81	22.5	6.5	2.5	2.3	970	89	<b>FD 08</b>	200	—	800	1045	119	<b>FA 08</b>	200	800	1030	118

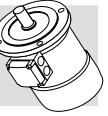
Pn kW		n min <sup>-1</sup>	Mn Nm	η %	cos φ	In [400V] A	Is In	Ms Mn	Ma Mn	Jm x 10 <sup>-4</sup> kgm <sup>2</sup>	IM B9 	freno c.c. / d.c. brake G.S.-bremse / frein c.c.					freno c.a. / a.c. brake W.S.-bremse / frein c.a.						
												FD					FA						
												Mod.	Mb Nm	Zo 1/h NB SB		Jm x 10 <sup>-4</sup> kgm <sup>2</sup>	IM B9 	Mod.	Mb Nm	Zo 1/h	Jm x 10 <sup>-4</sup> kgm <sup>2</sup>	IM B9 	
0.20 0.15	<b>M 05A</b>	2	2700	0.71	55	0.82	0.64	3.5	2.1	1.9	2.9	4.1	<b>FD 02</b>	3.5	2200	2600	3.5	5.8	<b>FA 02</b>	3.5	2600	3.5	5.6
		4	1350	1.06	49	0.67	0.66	2.6	1.8	1.7					4000	5100					5100		
0.28 0.20	<b>M 1SB</b>	2	2700	0.99	56	0.82	0.88	2.9	1.9	1.7	4.7	4	<b>FD 03</b>	3.5	2100	2400	5.8	6.7	<b>FA 03</b>	3.5	2400	5.8	6.4
		4	1370	1.39	59	0.68	1.02	3.1	1.8	1.7					3800	4800					4800		
0.37 0.25	<b>M 1SC</b>	2	2740	1.29	56	0.82	1.16	3.5	1.8	1.8	5.8	4.7	<b>FD 03</b>	5	1400	2100	6.9	7.4	<b>FA 03</b>	5	2100	6.9	7.1
		4	1390	1.72	60	0.73	0.82	3.3	2	1.9					2900	4200					4200		
0.45 0.30	<b>M 1SD</b>	2	2780	1.55	63	0.85	1.21	3.8	1.8	1.8	6.9	5.5	<b>FD 03</b>	5	1400	2100	8	8.2	<b>FA 03</b>	5	2100	8	7.9
		4	1400	2.0	63	0.74	0.93	3.8	2.1	1.9					2900	4200					4200		
0.55 0.37	<b>M 1LA</b>	2	2800	1.9	73	0.79	1.38	4.2	2	1.8	9.1	6.9	<b>FD 03</b>	5	1600	2200	10.2	9.6	<b>FA 03</b>	5	2200	10.2	9.3
		4	1400	2.5	68	0.72	1.09	3.9	2.2	2					3300	4600					4600		
0.75 0.55	<b>M 2SA</b>	2	2780	2.6	65	0.85	1.96	3.8	1.9	1.8	20	9.2	<b>FD 04</b>	10	1400	1600	22	13.1	<b>FA 04</b>	10	1600	22	13
		4	1400	3.8	68	0.81	1.44	3.9	1.7	1.7					2700	3600					3600		
1.1 0.75	<b>M 2SB</b>	2	2730	3.9	65	0.86	2.84	3.9	2	1.9	25	10.7	<b>FD 04</b>	10	1200	1500	27	14.5	<b>FA 04</b>	10	1500	27	14.5
		4	1410	5.1	75	0.81	1.78	4.5	2.1	2					2300	3100					3100		
1.5 1.1	<b>M 3SA</b>	2	2830	5.1	74	0.83	3.5	4.7	2.1	2	34	15.5	<b>FD 15</b>	26	700	1000	38	22	<b>FA 15</b>	26	1000	38	23
		4	1420	7.4	77	0.78	2.6	4.3	2.1	2					1600	2600					2600		
2.2 1.5	<b>M 3LA</b>	2	2800	7.5	72	0.85	5.2	4.5	2	1.9	40	17	<b>FD 15</b>	26	600	900	44	24	<b>FA 15</b>	26	900	44	24
		4	1410	10.2	73	0.79	3.8	4.7	2	2					1300	2300					2300		
3.5 2.5	<b>M 3LB</b>	2	2850	11.7	80	0.84	7.5	5.4	2.2	2.1	61	23	<b>FD 15</b>	40	500	900	65	29	<b>FA 15</b>	40	900	65	30
		4	1420	16.8	82	0.80	5.5	5.2	2.2	2.2					1000	2100					2100		
4.8 3.8	<b>M 4 SA</b>	2	2900	15.8	81	0.88	9.7	6	2	1.9	213	42	<b>FD 06</b>	50	—	400	233	55	<b>FA 06</b>	50	400	233	56
		4	1430	25.4	81	0.84	8.1	5.2	2.1	2.1					—	950					950		
5.5 4.4	<b>M 4SB</b>	2	2890	18.2	80	0.87	11.4	5.9	2.4	2	213	42	<b>FD 56</b>	75	—	350	223	55	<b>FA 06</b>	75	350	223	56
		4	1440	29	82	0.84	9.2	5.3	2.2	2					—	900					900		
7.5 6	<b>M 4LA</b>	2	2900	25	82	0.87	15.2	6.5	2.4	2	270	51	<b>FD 06</b>	100	—	350	280	64	<b>FA 07</b>	100	350	280	65
		4	1430	40	84	0.85	12.1	5.8	2.3	2.1					—	950					950		
9.2 7.3	<b>M 4LB</b>	2	2920	30	83	0.86	18.6	6	2.6	2.2	319	57	<b>FD 07</b>	150	—	300	342	73	<b>FA 07</b>	150	300	342	75
		4	1440	48	85	0.85	14.6	5.5	2.3	2.1					—	800					800		







**2/6 P****3000/1000 min<sup>-1</sup> - S3 60/40%****50 Hz**

Pn kW		n min <sup>-1</sup>	Mn Nm	η %	cos φ	In [400V] A	Is In	Ms Mn	Ma Mn	Jm x 10 <sup>-4</sup> kgm <sup>2</sup>	IM B9 	freno c.c. / d.c. brake G.S.-bremse / frein c.c.					freno c.a. / a.c. brake W.S.-bremse / frein c.a.						
												FD		FA			FD		FA				
												Mod.	Mb Nm	Zo 1/h NB SB	Jm x 10 <sup>-4</sup> kgm <sup>2</sup>	IM B9 	Mod.	Mb Nm	Zo 1/h	Jm x 10 <sup>-4</sup> kgm <sup>2</sup>	IM B9 		
0.25 0.08	<b>M 1SA</b>	2	2850	0.84	60	0.82	0.73	4.3	1.9	1.8	6.9	5.5	<b>FD 03</b>	1.75	1500	1700	8	8.2	<b>FA 03</b>	1.75	1700	8	7.9
		6	910	0.84	43	0.70	0.38	2.1	1.4	1.5	10000	13000			13000								
0.37 0.12	<b>M 1LA</b>	2	2880	1.23	62	0.80	1.08	4.4	1.9	1.8	9.1	6.9	<b>FD 03</b>	3.5	1000	1300	10.2	9.6	<b>FA 03</b>	3.5	1300	10.2	9.3
		6	900	1.27	44	0.73	0.54	2.4	1.4	1.5	9000	11000			11000								
0.55 0.18	<b>M 2SA</b>	2	2800	1.88	63	0.86	1.47	4.5	1.9	1.7	20	9.2	<b>FD 04</b>	5	1500	1800	22	13.1	<b>FA 04</b>	5	1800	22	13
		6	930	1.85	52	0.65	0.77	3.3	2.0	1.9	4100	6300			6300								
0.75 0.25	<b>M 2SB</b>	2	2800	2.6	66	0.87	1.89	4.3	1.8	1.6	25	10.6	<b>FD 04</b>	5	1700	1900	27	14.5	<b>FA 04</b>	5	1900	27	14.4
		6	930	2.6	54	0.67	1.00	3.2	1.7	1.8	3800	6000			6000								
1.1 0.37	<b>M 3SA</b>	2	2870	3.7	71	0.82	2.73	4.9	1.8	1.9	34	15.5	<b>FD 15</b>	13	1000	1300	38	22	<b>FA 15</b>	13	1300	38	23
		6	930	3.8	63	0.70	1.21	3.1	1.5	1.8	3500	5000			5000								
1.5 0.55	<b>M 3LA</b>	2	2880	5.0	73	0.84	3.53	5.1	1.9	2.0	40	17	<b>FD 15</b>	13	1000	1200	44	24	<b>FA 15</b>	13	1200	44	24
		6	940	5.6	64	0.67	1.85	3.5	1.7	1.8	2900	4000			4000								
2.2 0.75	<b>M 3LB</b>	2	2900	7.2	77	0.85	4.9	5.9	2.0	2.0	61	23	<b>FD 15</b>	26	700	900	65	29	<b>FA 15</b>	26	900	65	30
		6	950	7.5	67	0.64	2.5	3.3	1.9	1.8	2100	3000			3000								
3 1.1	<b>M 4SA</b>	2	2910	9.9	74	0.88	6.6	5.6	2.0	2.1	170	36	<b>FD 56</b>	37	—	600	182	48	<b>FA 06</b>	37	600	182	50
		6	960	10.9	73	0.68	3.2	4.5	2.2	2	—	2200			2200								
4.5 1.5	<b>M 4SB</b>	2	2910	14.8	78	0.84	9.9	5.8	1.9	1.8	213	42	<b>FD 56</b>	37	—	500	223	55	<b>FA 06</b>	37	500	223	56
		6	960	14.9	74	0.67	4.4	4.2	1.9	2.0	—	2100			2100								
5.5 2.2	<b>M 4LA</b>	2	2920	18.0	78	0.87	11.7	6.2	2.1	1.9	270	51	<b>FD 06</b>	50	—	400	280	64	<b>FA 06</b>	50	400	280	65
		6	960	22	77	0.71	5.8	4.3	2.1	2.0	—	1900			1900								

# 2/8 P



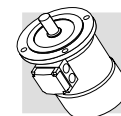

## 3000/750 min<sup>-1</sup> - S3 60/40%

### 50 Hz

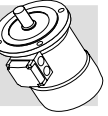
Pn kW		n min <sup>-1</sup>	Mn Nm	η %	cos φ	In [400V] A	Is In	Ms Mn	Ma Mn	Jm x 10 <sup>-4</sup> kgm <sup>2</sup>	IM B9 	freno c.c. / d.c. brake G.S.-bremse / frein c.c.					freno c.a. / a.c. brake W.S.-bremse / frein c.a.						
												FD					FA						
												Mod.	Mb Nm	Zo 1/h NB SB		Jm x 10 <sup>-4</sup> kgm <sup>2</sup>	IM B9 	Mod.	Mb Nm	Zo 1/h	Jm x 10 <sup>-4</sup> kgm <sup>2</sup>	IM B9 	
0.37 0.09	<b>M 1LA</b>	<b>2</b>	2800	1.26	63	0.86	0.99	3.9	1.8	1.9	12.9	7.3	<b>FD 03</b>	3.5	1200	1300	14	10	<b>FA 03</b>	3.5	1300	14	9.7
		<b>8</b>	670	1.28	34	0.75	0.51	1.8	1.4	1.5	9500	13000			13000								
0.55 0.13	<b>M 2SA</b>	<b>2</b>	2830	1.86	66	0.86	1.40	4.4	2.1	2	20	9.2	<b>FD 04</b>	5	1500	1800	22	13.1	<b>FA 04</b>	5	1800	22	13
		<b>8</b>	690	1.80	41	0.64	0.72	2.3	1.6	1.7	5600	8000			8000								
0.75 0.18	<b>M 2SB</b>	<b>2</b>	2800	2.6	68	0.88	1.81	4.6	2.1	2	25	10.6	<b>FD 04</b>	10	1700	1900	27	14.5	<b>FA 04</b>	10	1900	27	14.4
		<b>8</b>	690	2.5	43	0.66	0.92	2.3	1.6	1.7	4800	7300			7300								
1.1 0.28	<b>M 3SA</b>	<b>2</b>	2870	3.7	69	0.84	2.74	4.6	1.8	1.7	34	15.5	<b>FD 15</b>	13	1000	1300	38	22	<b>FA 15</b>	13	1300	38	23
		<b>8</b>	690	3.9	44	0.56	1.64	2.3	1.4	1.7	3400	5000			5000								
1.5 0.37	<b>M 3LA</b>	<b>2</b>	2880	5.0	69	0.85	3.69	4.7	1.9	1.8	40	17	<b>FD 15</b>	13	1000	1200	44	24	<b>FA 15</b>	13	1200	44	24
		<b>8</b>	690	5.1	46	0.63	1.84	2.1	1.6	1.6	3300	5000			5000								
2.4 0.55	<b>M 3LB</b>	<b>2</b>	2900	7.9	75	0.82	5.6	5.4	2.1	2	61	23	<b>FD 15</b>	26	550	700	65	29	<b>FA 15</b>	26	700	65	30
		<b>8</b>	700	7.5	54	0.58	2.5	2.6	1.8	1.8	2000	3500			3500								
3 0.75	<b>M 4SA</b>	<b>2</b>	2920	9.8	72	0.85	7.1	5.6	2	1.8	162	36	<b>FD 56</b>	37	—	600	182	48	<b>FA 06</b>	37	600	182	50
		<b>8</b>	710	10.1	61	0.64	2.8	3	1.7	1.8	—	3400			3400								
4 1	<b>M 4SB</b>	<b>2</b>	2870	13.3	73	0.84	9.4	5.6	2.3	2.4	213	42	<b>FD 56</b>	37	—	500	223	55	<b>FA 06</b>	37	500	223	56
		<b>8</b>	690	13.8	66	0.62	3.5	2.9	1.9	1.8	—	3500			3500								
5.5 1.5	<b>M 4LA</b>	<b>2</b>	2870	18.3	75	0.84	12.6	6.1	2.4	2.5	270	51	<b>FD 06</b>	50	—	400	280	64	<b>FA 06</b>	50	400	280	65
		<b>8</b>	690	21	68	0.63	5.1	2.9	1.9	1.9	—	2400			2400								



**2/12 P****3000/500 min<sup>-1</sup> - S3 60/40%****50 Hz**

Pn kW		n min <sup>-1</sup>	Mn Nm	η %	cos φ	In [400V] A	Is In	Ms Mn	Ma Mn	Jm x 10 <sup>-4</sup> kgm <sup>2</sup>	IM B9 	freno c.c. / d.c. brake G.S.-bremse / frein c.c.					freno c.a. / a.c. brake W.S.-bremse / frein c.a.						
												FD					FA						
												Mod.	Mb Nm	Zo 1/h NB SB		Jm x 10 <sup>-4</sup> kgm <sup>2</sup>	IM B9 	Mod.	Mb Nm	Zo 1/h	Jm x 10 <sup>-4</sup> kgm <sup>2</sup>	IM B9 	
0.55 0.09	<b>M 2SA</b>	<b>2</b>	2820	1.86	64	0.89	1.39	4.2	1.6	1.7	25	10.6	<b>FD 04</b>	5	1000	1300	27	14.5	<b>FA 04</b>	5	1300	27	14.4
		<b>12</b>	430	2.0	30	0.63	0.69	1.8	1.9	1.8	8000	12000			12000								
0.75 0.12	<b>M 3SA</b>	<b>2</b>	2900	2.5	65	0.81	2.06	5.2	1.9	2.1	34	15.5	<b>FD 15</b>	13	700	900	38	22	<b>FA 15</b>	13	900	38	23
		<b>12</b>	460	2.5	33	0.43	1.22	1.9	1.3	1.6	5000	7000			7000								
1.1 0.18	<b>M 3LA</b>	<b>2</b>	2850	3.7	65	0.85	2.87	4.5	1.6	1.8	40	17	<b>FD 15</b>	13	700	900	44	24	<b>FA 15</b>	13	900	44	24
		<b>12</b>	430	4.0	26	0.54	1.85	1.5	1.3	1.5	4000	6000			6000								
1.5 0.25	<b>M 3LB</b>	<b>2</b>	2900	4.9	67	0.86	3.76	5.6	1.9	1.9	54	21	<b>FD 15</b>	13	700	900	58	27	<b>FA 15</b>	13	900	58	28
		<b>12</b>	440	5.4	36	0.46	2.18	1.8	1.7	1.8	3800	5000			5000								
2 0.3	<b>M 3LC</b>	<b>2</b>	2850	6.7	70	0.84	4.9	4.9	1.8	1.7	61	23	<b>FD 55</b>	18	—	700	65	29	<b>FA 15</b>	18	700	65	30
		<b>12</b>	450	6.4	38	0.47	2.4	1.7	1.6	1.7	—	3500			3500								
3 0.5	<b>M 4SA</b>	<b>2</b>	2920	9.8	74	0.87	6.7	6.8	2.3	1.9	213	42	<b>FD 56</b>	37	—	450	223	55	<b>FA 06</b>	37	450	223	56
		<b>12</b>	470	10.2	51	0.43	3.3	2	1.7	1.6	—	3000			3000								
4 0.7	<b>M 4LA</b>	<b>2</b>	2920	13.1	75	0.89	8.6	5.9	2.4	2.3	270	51	<b>FD 56</b>	37	—	400	280	64	<b>FA 06</b>	37	400	280	65
		<b>12</b>	460	14.5	53	0.44	4.3	1.9	1.7	1.6	—	2800			2800								

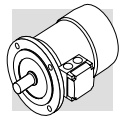

---

**M12 - DIMENSIONI MOTORI**

***M12 - MOTORS DIMENSIONS***

**M12 - MOTORENABMESSUN-  
GEN**

***M12 - DIMENSIONS  
MOTEURS***



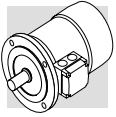

**BN**

**IM B14**

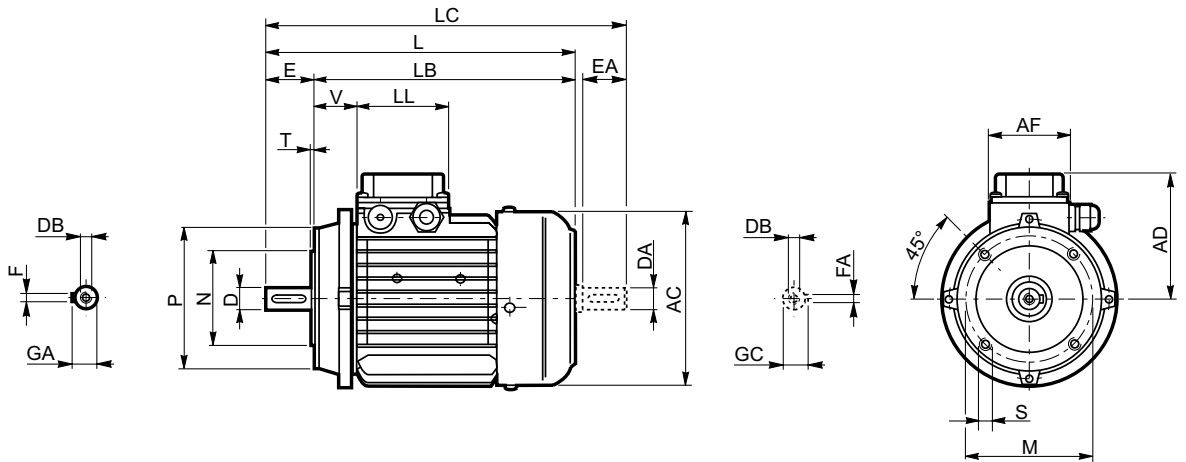

	Albero / Shaft / Welle / Arbre					Flangia / Flange / Flansch / Bride					Motore / Motor / Motor / Moteur							
	D DA	E EA	DB	GA GC	F FA	M	N	P	S	T	AC	L	LB	LC	AD	AF	LL	V
<b>BN 56</b>	9	20	M3	10.2	3	65	50	80	M5	2.5	110	185	165	207	91	74	80	34
<b>BN 63</b>	11	23	M4	12.5	4	75	60	90	M5	2.5	121	207	184	232	95	74	80	26
<b>BN 71</b>	14	30	M5	16	5	85	70	105	M6	2.5	138	249	219	281	108	74	80	37
<b>BN 80</b>	19	40	M6	21.5	6	100	80	120	M6	3	156	274	234	315	119	74	80	38
<b>BN 90</b>	24	50	M8	27	8	115	95	140	M8	3	176	326	276	378	133	98	98	44
<b>BN 100</b>	28	60	M10	31	8	130	110	160	M8	3.5	195	366	306	429	142	98	98	50
<b>BN 112</b>	28	60	M10	31	8	130	110	160	M8	3.5	219	385	325	448	157	98	98	52
<b>BN 132</b>	38	80	M12	41	10	165	130	200	M10	4	258	493	413	576	193	118	118	58

N.B.:

1) Queste dimensioni sono riferite alla seconda estremità d'albero.

NOTE:

1) These values refer to the rear shaft end.

HINWEIS:

1) Diese Maße betreffen das zweite Wellenende.

REMARQUE :

1) Ces dimensions se réfèrent à la deuxième extrémité de l'arbre.

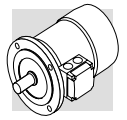

**BN**

**IM B5**

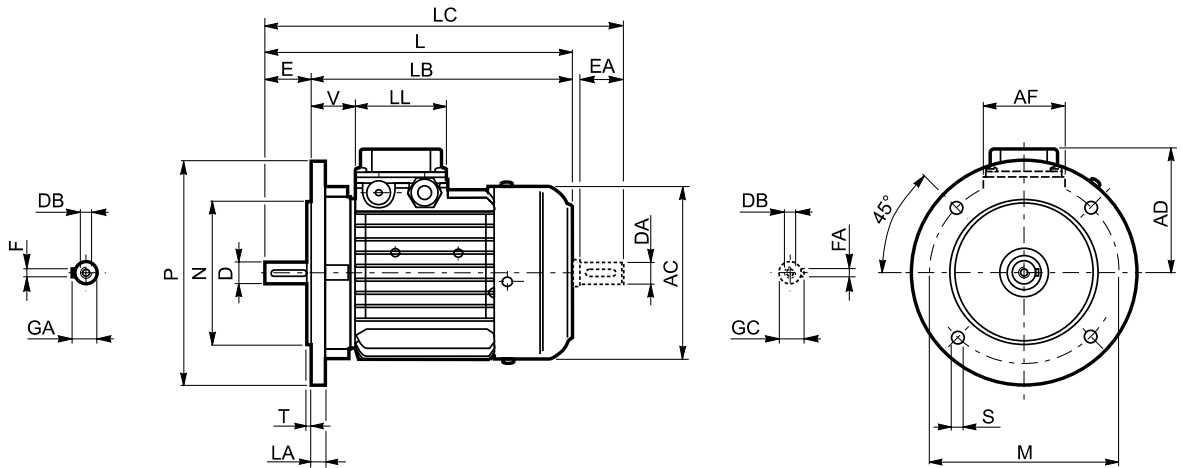

	Albero / Shaft / Welle / Arbre					Flangia / Flange / Flansch / Bride						Motore / Motor / Motor / Moteur							
	D DA	E EA	DB	GA GC	F FA	M	N	P	S	T	LA	AC	L	LB	LC	AD	AF	LL	V
<b>BN 56</b>	9	20	M3	10.2	3	100	80	120	7	3	8	110	185	165	207	91	74	80	34
<b>BN 63</b>	11	23	M4	12.5	4	115	95	140	9.5	3	10	121	207	184	232	95	74	80	26
<b>BN 71</b>	14	30	M5	16	5	130	110	160	9.5	3	10	138	249	219	281	108	74	80	37
<b>BN 80</b>	19	40	M6	21.5	6	165	130	200	11.5	3.5	11.5	156	274	234	315	119	74	80	38
<b>BN 90</b>	24	50	M8	27	8	165	130	200	11.5	3.5	11.5	176	326	276	378	133	98	98	44
<b>BN 100</b>	28	60	M10	31	8	215	180	250	14	4	14	195	367	307	429	142	98	98	50
<b>BN 112</b>	28	60	M10	31	8	215	180	250	14	4	15	219	385	325	448	157	98	98	52
<b>BN 132</b>	38	80	M12	41	10	265	230	300	14	4	16	258	493	413	576	193	118	118	58
<b>BN 160 MR</b>	42 38 (1)	110 80 (1)	M16 M12 (1)	45 41 (1)	12 10 (1)	300	250	350	18.5	5	15	258	562	452	645	193	118	118	218
<b>BN 160 M</b>	42 38 (1)	110 80 (1)	M16 M12 (1)	45 41 (1)	12 10 (1)	300	250	350	18.5	5	15	310	596	486	680	245	187	187	51
<b>BN 160 L</b>	42 38 (1)	110 80 (1)	M16 M12 (1)	45 41 (1)	12 10 (1)	300	250	350	18.5	5	15	310	596	486	680	245	187	187	51
<b>BN 180 M</b>	48 38 (1)	110 110 (1)	M16 M12 (1)	51.5 41 (1)	14 10 (1)	300	250	350	18.5	5	15	310	640	530	724	245	187	187	51
<b>BN 180 L</b>	48 42 (1)	110 110 (1)	M16 M16 (1)	51.5 45 (1)	14 12 (1)	300	250	350	18.5	5	18	348	708	598	823	261	187	187	52
<b>BN 200 L</b>	55 42 (1)	110 110 (1)	M20 M16 (1)	59 45 (1)	16 12 (1)	350	300	400	18.5	5	18	348	722	612	837	261	187	187	66

N.B.:

1) Queste dimensioni sono riferite alla seconda estremità d'albero.

NOTE:

1) These values refer to the rear shaft end.

HINWEIS:

1) Diese Maße betreffen das zweite Wellenende.

REMARQUE :

1) Ces dimensions se réfèrent à la deuxième extrémité de l'arbre.

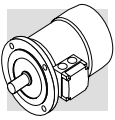

# BN\_FD

## IM B14

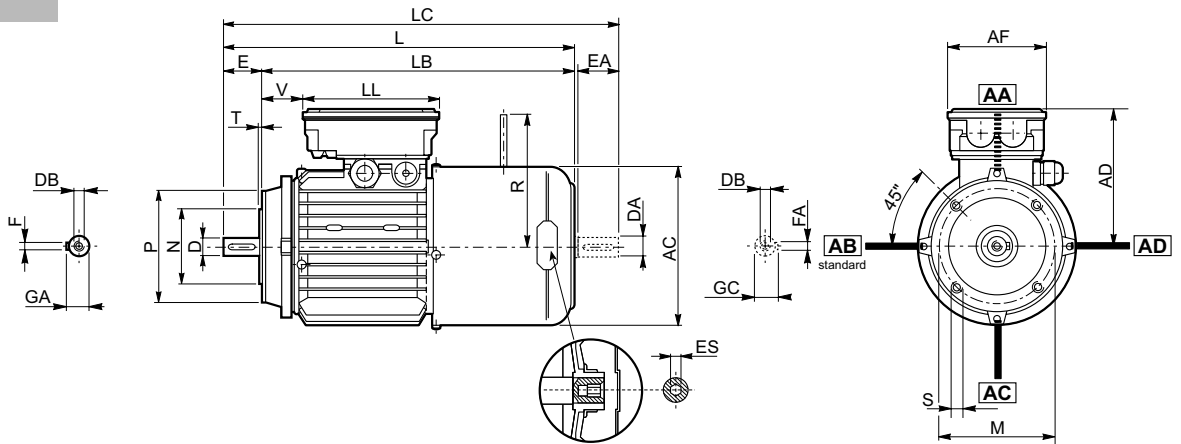

	Albero / Shaft / Welle / Arbre					Flangia / Flange / Flansch / Bride					Motore / Motor / Motor / Moteur									
	D DA	E EA	DB	GA GC	F FA	M	N	P	S	T	AC	L	LB	LC	AD	AF	LL	V	R	ES
<b>BN 63</b>	11	23	M4	12.5	4	75	60	90	M5	2.5	121	272	249	297	119	98	133	14	96	5
<b>BN 71</b>	14	30	M5	16	5	85	70	105	M6	2.5	138	310	280	342	132	98	133	30	103	5
<b>BN 80</b>	19	40	M6	21.5	6	100	80	120	M6	3	156	346	306	388	143	98	133	41	129	5
<b>BN 90</b>	24	50	M8	27	8	115	95	140	M8	3	176	409	359	461	146	110	165	39	160	6
<b>BN 100</b>	28	60	M10	31	8	130	110	160	M8	3.5	195	458	398	521	155	110	165	62	160	6
<b>BN 112</b>	28	60	M10	31	8	130	110	160	M8	3.5	219	484	424	547	170	110	165	73	199	6
<b>BN 132</b>	38	80	M12	41	10	165	130	200	M10	4	258	603	523	686	193	118	118	180	204 (2)	6

N.B.:

- 1) Queste dimensioni sono riferite alla seconda estremità d'albero.
- 2) Per freno FD07 quota R=226.

NOTE:

- 1) These values refer to the rear shaft end.
- 2) For FD07 brake value R=226.

HINWEIS:

- 1) Diese Maße betreffen das zweite Wellenende.
- 2) Für Bremse FD07, Maß R=226.

REMARQUE :

- 1) Ces dimensions se réfèrent à la deuxième extrémité de l'arbre.
- 2) Pour frein FD07 valeur R=226.

L'esagono ES non è presente con l'opzione PS.

ES hexagon is not supplied with PS option.

Der Sechskant ES ist bei der Option PS nicht vorhanden.

L'hexagone ES n'est pas disponible avec l'option PS.

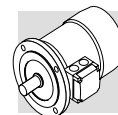

# BN\_FD

## IM B5

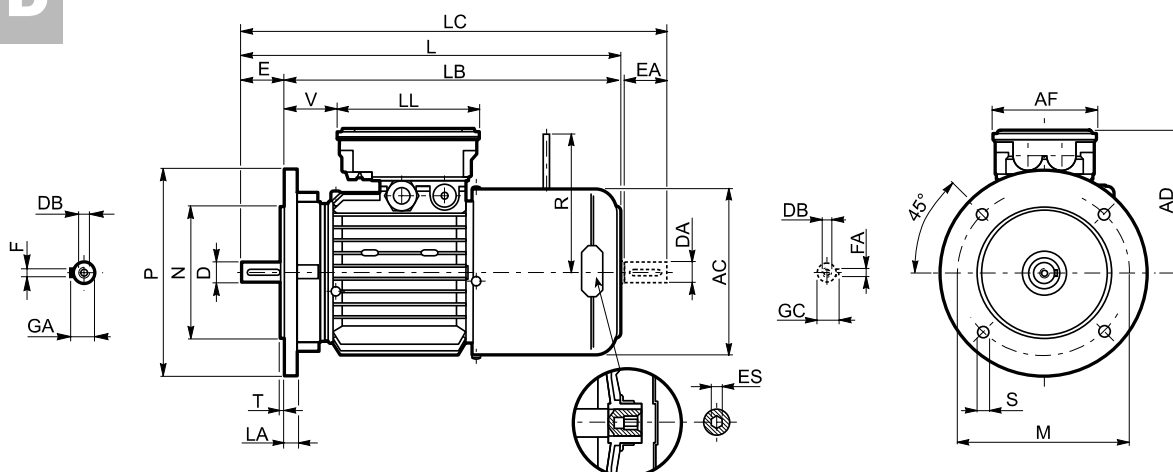

	Albero / Shaft / Welle / Arbre					Flangia / Flange / Flansch / Bride						Motore / Motor / Motor / Moteur									
	D DA	E EA	DB	GA GC	F FA	M	N	P	S	T	LA	AC	L	LB	LC	AD	AF	LL	V	R	ES
<b>BN 63</b>	11	23	M4	12.5	4	115	95	140	9.5	3	10	121	272	249	297	119	98	133	14	96	5
<b>BN 71</b>	14	30	M5	16	5	130	110	160	9.5	3.5	10	138	310	280	342	132	98	133	30	103	5
<b>BN 80</b>	19	40	M6	21.5	6	165	130	200	11.5	3.5	11.5	156	346	306	388	143	98	133	41	129	5
<b>BN 90</b>	24	50	M8	27	8	165	130	200	11.5	3.5	11.5	176	409	359	461	146	110	165	39	160	6
<b>BN 100</b>	28	60	M10	31	8	215	180	250	14	4	14	195	458	398	521	155	110	165	62	160	6
<b>BN 112</b>	28	60	M10	31	8	215	180	250	14	4	15	219	484	424	547	170	110	165	73	199	6
<b>BN 132</b>	38	80	M12	41	10	265	230	300	14	4	16	258	603	523	686	193	118	118	180	204 (2)	6
<b>BN 160 MR</b>	42 38 (1)	110 80 (1)	M16 M12 (1)	45 41 (1)	12 10 (1)	300	250	350	18.5	5	15	258	672	562	755	193	118	118	218	226	6
<b>BN 160 M</b>	42 38 (1)	110 80 (1)	M16 M12 (1)	45 41 (1)	12 10 (1)	300	250	350	18.5	5	15	310	736	626	820	245	187	187	51	266	
<b>BN 160 L</b>	42 38 (1)	110 80 (1)	M16 M12 (1)	45 41 (1)	12 10 (1)	300	250	350	18.5	5	15	310	736	626	820	245	187	187	51	266	
<b>BN 180 M</b>	48 38 (1)	110 110 (1)	M16 M12 (1)	51.5 41 (1)	14 10 (1)	300	250	350	18.5	5	15	310	780	670	864	245	187	187	51	266	
<b>BN 180 L</b>	48 42 (1)	110 110 (1)	M16 M16 (1)	51.5 45 (1)	14 12 (1)	300	250	350	18.5	5	18	348	866	756	981	261	187	187	52	305	
<b>BN 200 L</b>	55 42 (1)	110 110 (1)	M20 M16 (1)	59 45 (1)	16 12 (1)	350	300	400	18.5	5	18	348	878	768	993	261	187	187	64	305	

N.B.:

1) Queste dimensioni sono riferite alla seconda estremità d'albero.

2) Per freno FD07 quota R=226.

NOTE:

1) These values refer to the rear shaft end.

2) For FD07 brake value R=226.

HINWEIS:

1) Diese Maße betreffen das zweite Wellenende.

2) Für Bremse FD07, Maß R=226.

REMARQUE :

1) Ces dimensions se réfèrent à la deuxième extrémité de l'arbre.

2) Pour frein FD07 valeur R=226.

L'esagono ES non è presente con l'opzione PS.

ES hexagon is not supplied with PS option.

Der Sechskant ES ist bei der Option PS nicht vorhanden.

L'hexagone ES n'est pas disponible avec l'option PS.

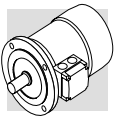

# BN\_FA

## IM B14

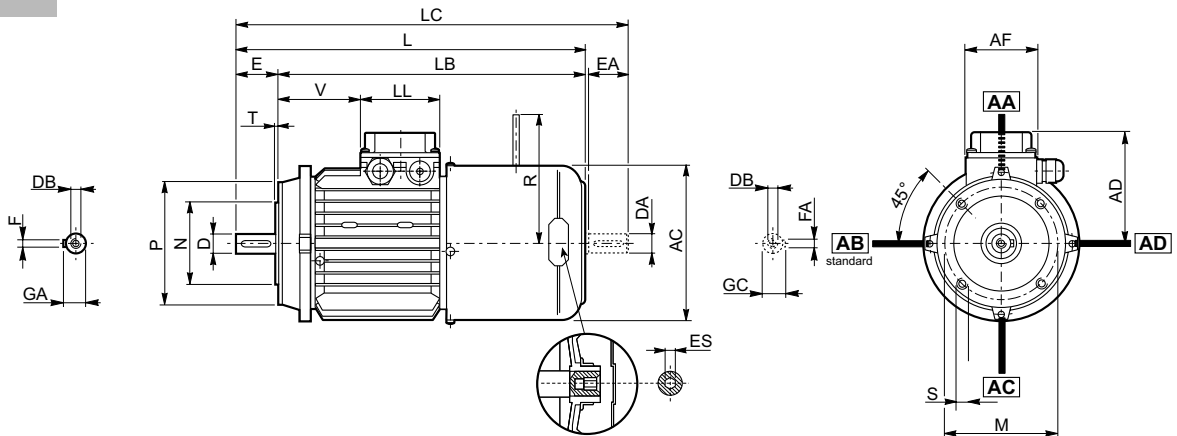

	Albero / Shaft / Welle / Arbre					Flangia / Flange / Flansch / Bride					Motore / Motor / Motor / Moteur									
	D DA	E EA	DB	GA GC	F FA	M	N	P	S	T	AC	L	LB	LC	AD	AF	LL	V	R	ES
<b>BN 63</b>	11	23	M4	12.5	4	75	60	90	M5	2.5	121	272	249	119	95	74	80	26	116	5
<b>BN 71</b>	14	30	M5	16	5	85	70	105	M6	2.5	138	310	280	342	108	74	80	68	124	5
<b>BN 80</b>	19	40	M6	21.5	6	100	80	120	M6	3	156	346	306	388	119	74	80	83	134	5
<b>BN 90</b>	24	50	M8	27	8	115	95	140	M8	3	176	409	359	461	133	98	98	95	160	6
<b>BN 100</b>	28	60	M10	31	8	130	110	160	M8	3.5	195	458	398	521	142	98	98	119	160	6
<b>BN 112</b>	28	60	M10	31	8	130	110	160	M8	3.5	219	484	424	547	157	98	98	128	198	6
<b>BN 132</b>	38	80	M12	41	10	165	130	200	M10	4	258	603	523	686	193	118	118	180	200 (2)	6

**N.B.:**

- 1) Queste dimensioni sono riferite alla seconda estremità d'albero.
- 2) Per freno FD07 quota R=226.

**NOTE:**

- 1) These values refer to the rear shaft end.
- 2) For FD07 brake value R=226.

**HINWEIS:**

- 1) Diese Maße betreffen das zweite Wellenende.
- 2) Für Bremse FD07, Maß R=226.

**REMARQUE :**

- 1) Ces dimensions se réfèrent à la deuxième extrémité de l'arbre.
- 2) Pour frein FD07 valeur R=226.

Per la versione BN..FA le dimensioni della scatola morsetti AD, AF, LL, V sono uguali al tipo BN..FD.

For motors type BN..FA, the terminal box sizes AD, AF, LL, V are the same as for BN..FD.

Bei der Motor typ BN..FA sind die Maße des Klemmenkastens AD, AF, LL, V denen der Version BN..FD gleich.

Pour moteurs type BN..FA les dimensions de la boîte à bornes AD, AF, LL, V sont les mêmes de BN..FD.

L'esagono ES non è presente con l'opzione PS.

ES hexagon is not supplied with PS option.

Der Sechskant ES ist bei der Option PS nicht vorhanden.

L'hexagone ES n'est pas disponible avec l'option PS.

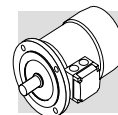

# BN\_FA

## IM B5

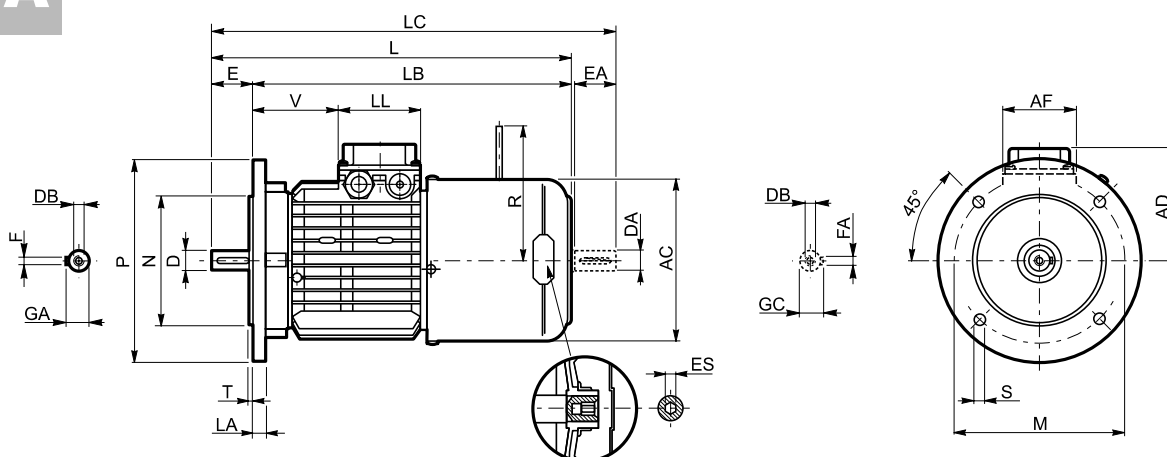

	Albero / Shaft / Welle / Arbre					Flangia / Flange / Flansch / Bride						Motore / Motor / Motor / Moteur									
	D DA	E EA	DB	GA GC	F FA	M	N	P	S	T	LA	AC	L	LB	LC	AD	AF	LL	V	R	ES
<b>BN 63</b>	11	23	M4	12.5	4	115	95	140	9.5	3	10	121	272	249	297	95	74	80	26	116	5
<b>BN 71</b>	14	30	M5	16	5	130	110	160	9.5	3.5	10	138	310	280	342	108	74	80	68	124	5
<b>BN 80</b>	19	40	M6	21.5	6	165	130	200	11.5	3.5	11.5	156	346	306	388	119	74	80	83	134	5
<b>BN 90</b>	24	50	M8	27	8	165	130	200	11.5	3.5	11.5	176	409	359	461	133	98	98	95	160	6
<b>BN 100</b>	28	60	M10	31	8	215	180	250	14	4	14	195	458	398	521	142	98	98	119	160	6
<b>BN 112</b>	28	60	M10	31	8	215	180	250	14	4	15	219	484	424	547	157	98	98	128	198	6
<b>BN 132</b>	38	80	M12	41	10	265	230	300	14	4	16	258	603	523	686	193	118	118	180	200 (2)	6
<b>BN 160 MR</b>	42 38 (1)	110 80 (1)	M16 M12 (1)	45 41 (1)	12 10 (1)	300	250	350	18.5	5	15	258	672	562	755	193	118	118	218	217	6
<b>BN 160 M</b>	42 38 (1)	110 80 (1)	M16 M12 (1)	45 41 (1)	12 10 (1)	300	250	350	18.5	5	15	310	736	626	820	245	187	187	51	247	—
<b>BN 160 L</b>	42 38 (1)	110 80 (1)	M16 M12 (1)	45 41 (1)	12 10 (1)	300	250	350	18.5	5	15	310	736	626	820	245	187	187	51	247	—
<b>BN 180 M</b>	48 38 (1)	110 80 (1)	M16 M12 (1)	51.5 41 (1)	14 10 (1)	300	250	350	18.5	5	15	310	780	670	864	245	187	187	51	247	—

N.B.:

- 1) Queste dimensioni sono riferite alla seconda estremità d'albero.
- 2) Per freno FD07 quota R=226.

NOTE:

- 1) These values refer to the rear shaft end.
- 2) For FD07 brake value R=226.

HINWEIS:

- 1) Diese Maße betreffen das zweite Wellenende.
- 2) Für Bremse FD07, Maß R=226.

REMARQUE :

- 1) Ces dimensions se réfèrent à la deuxième extrémité de l'arbre.
- 2) Pour frein FD07 valeur R=226.

Le dimensioni AD, AF, LL e V relative alla scatola morsetteria dei motori BN...FA dotati di alimentazione separata del freno (opzione SA) coincidono con quelle dei motori BN...FD di pari taglia.

Dimensions AD, AF, LL and V, relevant to terminal box of motors BN...FA featuring the separate brake supply (option SA), are coincident with corresponding dimensions of same-size BN...FD motors.

Die Abmessungen des Klemmenkastens der Motoren BN ... FA AD, AF, LL und V in bezug auf die separate Spannungsversorgung (Option SA) stimmen mit den Abmessungen der entsprechenden Motoren BN...FD überein.

Les dimensions AD, AF, LL et V relatives à la boîte à borne des moteurs BN...FA équipés d'alimentation séparée du frein (option SA) sont identiques à celles des moteurs BN...FD de la même taille.

L'esagono ES non è presente con l'opzione PS.

ES hexagon is not supplied with PS option.

Der Sechskant ES ist bei der Option PS nicht vorhanden.

L'hexagone ES n'est pas disponible avec l'option PS.

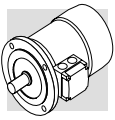

# BN\_BA

## IM B14

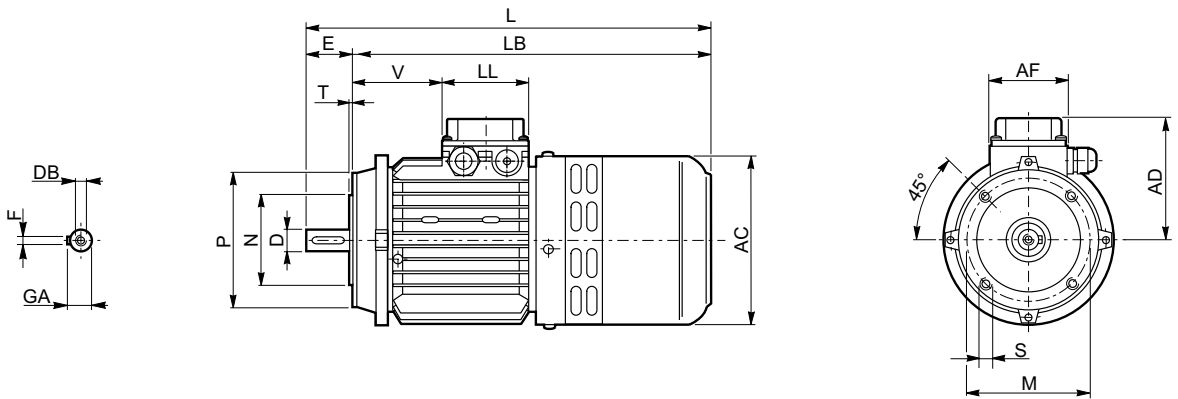

	Albero / Shaft / Welle / Arbre					Flangia / Flange / Flansch / Bride					Motore / Motor / Motor / Moteur						
	D DA	E EA	DB	GA GC	F FA	M	N	P	S	T	AC	L	LB	AD	AF	LL	V
<b>BN 63</b>	11	23	M4	12.5	4	75	60	90	M5	2.5	124	298	275	95	74	80	28
<b>BN 71</b>	14	30	M5	16	5	85	70	105	M6	2.5	138	327	297	108	74	80	68
<b>BN 80</b>	19	40	M6	21.5	6	100	80	120	M6	3	156	372	332	119	74	80	83
<b>BN 90</b>	24	50	M8	27	8	115	95	140	M8	3	176	425	375	133	98	98	95
<b>BN 100</b>	28	60	M10	31	8	130	110	160	M8	3.5	195	477	417	142	98	98	119
<b>BN 112</b>	28	60	M10	31	8	130	110	160	M8	3.5	219	500	440	157	98	98	128
<b>BN 132</b>	38	80	M12	41	10	165	130	200	M10	4	258	638	558	193	118	118	180

### N.B.:

Le dimensioni AD, AF, LL e V relative alla scatola morsetti dei motori BN...BA dotati di alimentazione separata del freno (opzione SA) coincidono con quelle dei motori BN...FD di pari taglia.

### NOTE:

Dimensions AD, AF, LL and V, relevant to terminal box of motors BN...BA featuring the separate brake supply (option SA), are coincident with corresponding dimensions of same-size BN...FD motors

### HINWEIS:

Die Abmessungen des Klemmenkastens der Motoren BN ... BA AD, AF, LL und V in bezug auf die separate Spannungsversorgung (Option SA) stimmen mit den Abmessungen der entsprechenden Motoren BN...FD überein.

### REMARQUE :

Les dimensions AD, AF, LL et V relatives à la boîte à borne des moteurs BN...BA équipés d'alimentation séparée du frein (option SA) sont identiques à celles des moteurs BN...FD de la même taille.

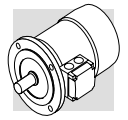

# BN\_BA

## IM B5

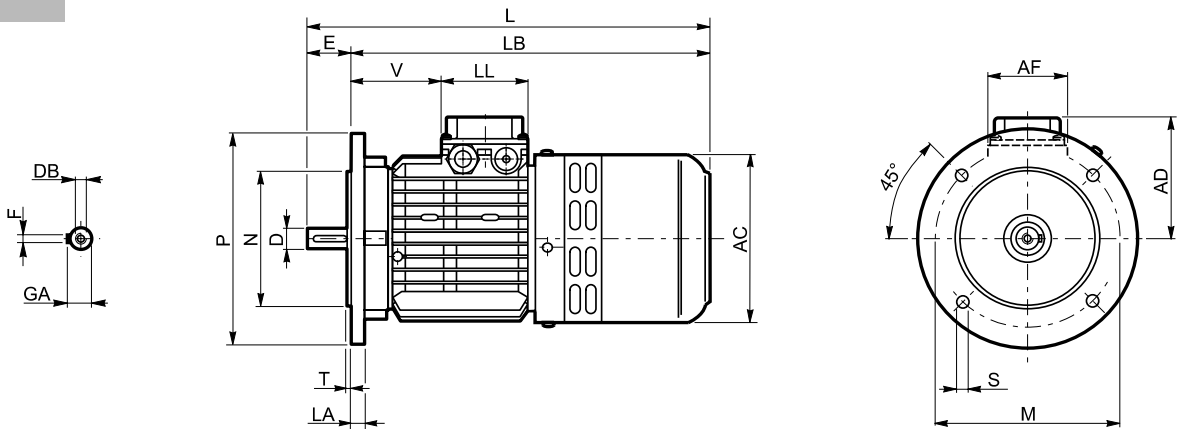

	Albero / Shaft / Welle / Arbte					Flangia / Flange / Flansch / Bride						Motore / Motor / Motor / Moteur						
	D DA	E EA	DB	GA GC	F FA	M	N	P	S	T	LA	AC	L	LB	AD	AF	LL	V
<b>BN63</b>	11	23	M4	12.5	4	115	95	140	9.5	3	10	124	298	275	95	74	80	28
<b>BN 71</b>	14	30	M5	16	5	130	110	160	9.5	3.5	10	138	327	297	108	74	80	68
<b>BN 80</b>	19	40	M6	21.5	6	165	130	200	11.5	3.5	11.5	156	372	332	119	74	80	83
<b>BN 90</b>	24	50	M8	27	8	165	130	200	11.5	3.5	11.5	176	425	375	133	98	98	95
<b>BN 100</b>	28	60	M10	31	8	215	180	250	14	4	14	195	477	417	142	98	98	119
<b>BN 112</b>	28	60	M10	31	8	215	180	250	14	4	15	219	500	440	157	98	98	128
<b>BN 132</b>	38	80	M12	41	10	265	230	300	14	4	16	258	638	558	193	118	118	180

**N.B.:**

Le dimensioni AD, AF, LL e V relative alla scatola morsetti dei motori BN...BA dotati di alimentazione separata del freno (opzione SA) coincidono con quelle dei motori BN...FD di pari taglia.

**NOTE:**

Dimensions AD, AF, LL and V, relevant to terminal box of motors BN...BA featuring the separate brake supply (option SA), are coincident with corresponding dimensions of same-size BN...FD motors

**HINWEIS:**

Die Abmessungen des Klemmkastens der Motoren BN ... BA AD, AF, LL und V in bezug auf die separate Spannungsversorgung (Option SA) stimmen mit den Abmessungen der entsprechenden Motoren BN...FD überein.

**REMARQUE :**

Les dimensions AD, AF, LL et V relatives à la boîte à borne des moteurs BN...BA équipés d'alimentation séparée du frein (option SA) sont identiques à celles des moteurs BN...FD de la même taille.



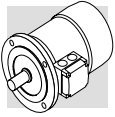

# M

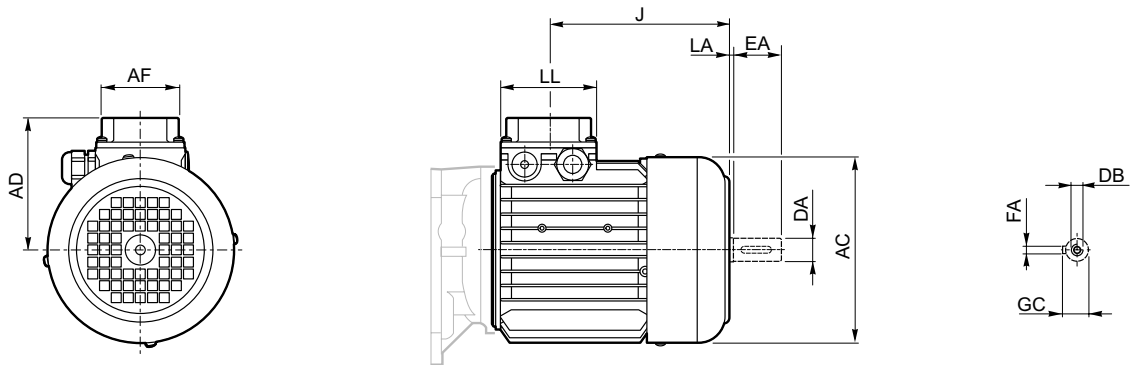

	AC	AD	AF	LL	J	DA	EA	LA	DB	GC	FA
<b>M 0</b>	110	91	74	80	91	9	20	2	M3	10.2	3
<b>M 05</b>	121	95	74	80	117	11	23	3	M4	12.5	4
<b>M 1S</b>	138	108	74	80	118	14	30	2	M5	16	5
<b>M 1L</b>	138	108	74	80	142	14	30	2	M5	16	5
<b>M 2S</b>	156	119	74	80	152	19	40	3	M6	21.5	6
<b>M 3S</b>	195	142	98	98	176.5	28	60	3	M10	31	8
<b>M 3L</b>	195	142	98	98	208.5	28	60	3	M10	31	8
<b>M 4</b>	258	193	118	118	296.5	38	80	3	M12	41	10
<b>M 4LC</b>	258	193	118	118	331.5	38	80	3	M12	41	10
<b>M 5S</b>	310	245	187	187	341.5	38	80	4	M12	41	10
<b>M 5L</b>	310	245	187	187	385	38	80	4	M12	41	10

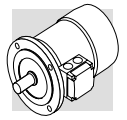

# M\_FD

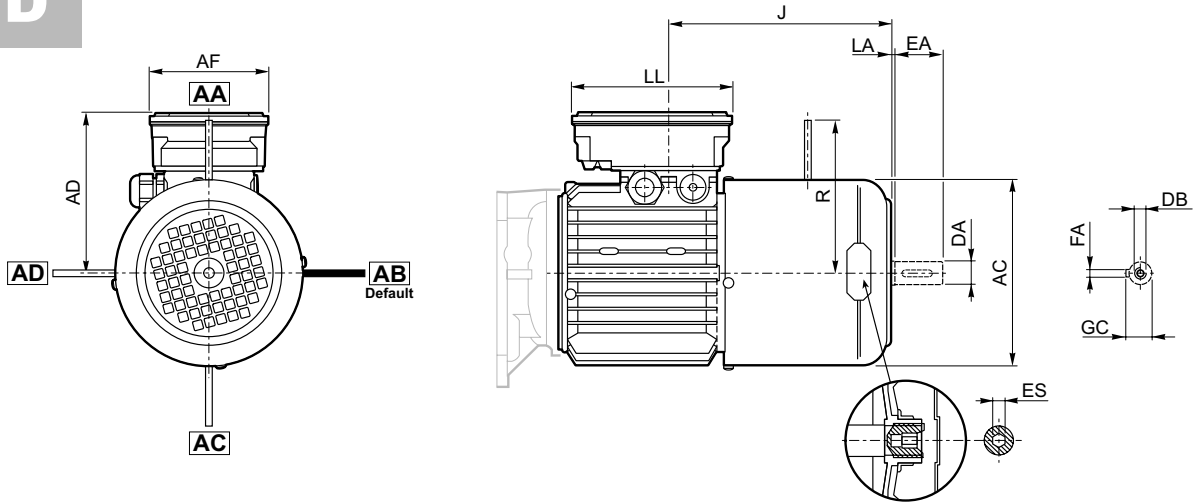

	AC	AD	AF	LL	J	R	DA	EA	LA	DB	GC	FA	ES
<b>M 05</b>	121	119	98	133	183	96	11	23	2	M4	12.5	4	5
<b>M 1S</b>	138	132	98	133	153	103	14	30	2	M5	16	5	5
<b>M 1L</b>	138	132	98	133	175	103	14	30	2	M5	16	5	5
<b>M 2S</b>	156	143	98	133	184	129	19	40	2	M6	21.5	6	5
<b>M 3S</b>	195	155	110	165	202	160	28	60	3	M10	31	8	6
<b>M 3L</b>	195	155	110	165	229	160	28	60	3	M10	31	8	6
<b>M 4</b>	258	193	118	118	285	226	38	80	3	M12	41	10	6
<b>M 4LC</b>	258	193	118	118	431	226	38	80	3	M12	41	10	6
<b>M 5S</b>	310	245	187	187	481	266	38	80	4	M12	41	10	—
<b>M 5L</b>	310	245	187	187	525	266	38	80	4	M12	41	10	—

N.B.:

L'esagono ES non è presente con l'opzione PS.

NOTE:

The hexagonal socket "ES" is not available with the PS option.

HINWEIS:

Der Sechskant ES ist bei der Option PS nicht vorhanden.

REMARQUE :

L'hexagone ES n'est pas disponible avec l'option PS.

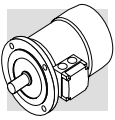

# M\_FA

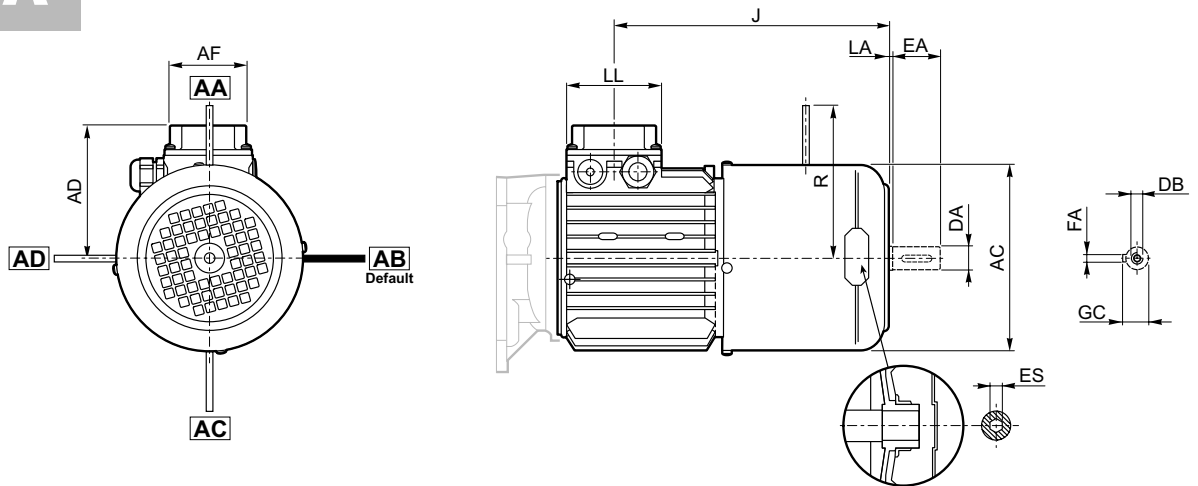

	AC	AD	AF	LL	J	R	DA	EA	LA	DB	GC	FA	ES
<b>M 05</b>	121	95	74	80	183	116	11	23	2	M4	12.5	4	5
<b>M 1S</b>	138	108	74	80	153	124	14	30	2	M5	16	5	5
<b>M 1L</b>	138	108	74	80	175	124	14	30	2	M5	16	5	5
<b>M 2S</b>	156	119	74	80	184	134	19	40	2	M6	21.5	6	5
<b>M 3S</b>	195	142	98	98	202	160	28	60	3	M10	31	8	6
<b>M 3L</b>	195	142	98	98	229	160	28	60	3	M10	31	8	6
<b>M 4</b>	258	193	118	118	285	217	38	80	3	M14	41	10	6
<b>M 4LC</b>	258	193	118	118	431	217	38	80	3	M14	41	10	6
<b>M 5S</b>	310	245	187	187	481	247	38	80	4	M12	41	10	—
<b>M 5L</b>	310	245	187	187	525	247	38	80	4	M12	41	10	—

N.B.:

L'esagono ES non è presente con l'opzione PS.

NOTE:

The hexagonal socket "ES" is not available with the PS option.

HINWEIS:

Der Sechskant ES ist bei der Option PS nicht vorhanden.

REMARQUE :

L'hexagone ES n'est pas disponible avec l'option PS.

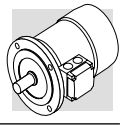

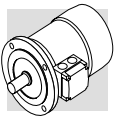

R8				
Descrizione	Description	Beschreibung	Description	
<div style="border: 1px solid black; padding: 2px; width: 20px; float: left; margin-right: 5px;">183 ... 184</div> <div style="border: 1px solid black; padding: 2px; width: 20px; float: left; margin-right: 5px;">192 ... 193</div>	Upgrade motori a eff2 M e BN a 2 e 4 poli	<i>Electric motor section ad-journed with the rating of eff2 motors (BN and M 2 and 4 poles).</i>	Abschnitt der Elektor-Motoren um Bemessungsdaten für EFF2 Motoren erweitert.	<i>Les données techniques des moteurs électriques M et BN à 2 et 4 pôles ont été mises à jour avec la classification eff2.</i>
<div style="border: 1px solid black; padding: 2px; width: 20px; float: left; margin-right: 5px;">124 ... 142</div> <div style="border: 1px solid black; padding: 2px; width: 20px; float: left; margin-right: 5px;">200 ... 207</div>	Unificate dimensioni di ingombro per motori BN 132S e BN 132M.	<i>Unified dimension for motor BN 132S and BN 132M.</i>	Vereinheitlichte Abmessungen für Motoren BN 132S und BN 132M.	<i>Les dimensions des moteurs BN 132S et BN 132M sont à présent identiques.</i>
<div style="border: 1px solid black; padding: 2px; width: 20px; float: left; margin-right: 5px;">123 ... 141</div> <div style="border: 1px solid black; padding: 2px; width: 20px; float: left; margin-right: 5px;">208 ... 210</div>	Unificate dimensioni di ingombro per motori M 4S e M 4L.	<i>Unified dimension for motor M4S and M4L.</i>	Vereinheitlichte Abmessungen für Motoren M 4S und M 4L	<i>Les dimensions des moteurs M 4S et M 4L sont à présent identiques.</i>

Questa pubblicazione annulla e sostituisce ogni precedente edizione o revisione. Ci riserviamo il diritto di apportare modifiche senza preavviso. È vietata la produzione anche parziale senza autorizzazione.

*This publication supersedes and replaces any previous edition and revision. We reserve the right to implement modifications without notice. This catalogue cannot be reproduced, even partially, without prior consent.*

Diese Veröffentlichung annulliert und ersetzt jeder hergehende Edition oder Revision. BONFIGLIOLI behält sich das Recht vor, Änderungen ohne vorherige Informationen durchzuführen.

*Cette publication annule et remplace toutes les autres précédentes. Nous nous réservons le droit d'apporter toutes modifications à nos produits. La reproduction et la publication partielle ou totale de ce catalogue est interdite sans notre autorisation.*

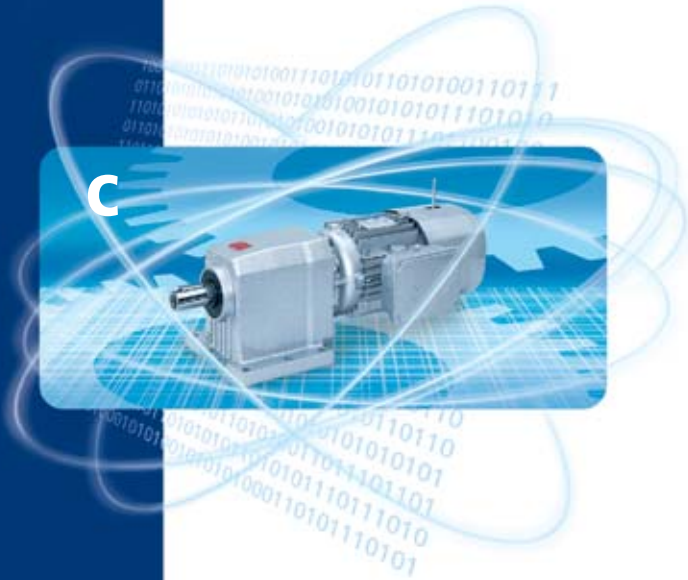

[www.bonfiglioli.com](http://www.bonfiglioli.com)

 **BONFIGLIOLI**